

DATA SHEET

Subject to change without notice

MODEL :- TSC-VC Powered Signal Conditioner V/C input

TECHNICAL DATA

Power Supply.

Nominal 120, 220/240 (40-60Hz) +/- 15%
24VDC (20 – 32vdc)
VA Rating Typically 2.0VA

Input (link selectable)

mV dc 0-1mV up to 0-1000mV
V dc 0-1V, 0-2V, 0-5V, 0-10v,0-20V etc
mA dc 0-1mA, 0-5mA, 0-10mA, 0-20mA,
0-50mA, 4-20mA, 10-50mA etc

Input Impedance 10Mohm

Others upon request

Output (two as standard)

No 1 (fixed) 0-10Vdc
No 2 (selected) 4-20mA etc (max loop load 900R)
Any others upon request.

GENERAL SPECIFICATION

Accuracy	0.1% of span
Linearity	0.1% of span
Repeatability	0.1% over 10,000 hrs
Common Mode RR	120dB
Response time	10 to 90% step in
250mSecs	
Drift	0.03% of span per Deg C
Isolation level	2500Vrms between input, output and power supply

Controls & Indication	External Span/Zero adjust. External Monitor 0-10Vdc
-----------------------	--

Operating Temp	0 to 60 Deg C
Storage Temp	0 to 75 Deg C
Terminals	Self opening
2.5mm/12AWG	
Housing Material	KRILEN (non-combustible)
Mounting Style	DIN (or G rail with adaptor)
Dimensions	105mm X 75mm X 45mm
Weight	130 grams

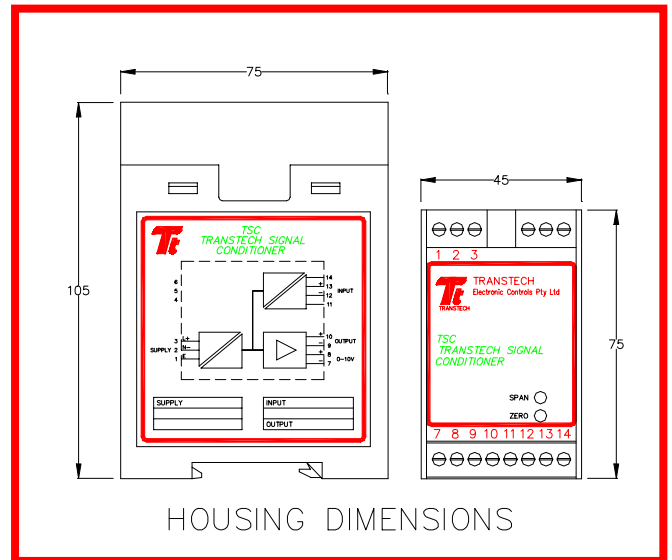

GENERAL DESCRIPTION

The **TSC series** of signal conditioners accepts a range of inputs such as :- AC volts, AC current, DC millivolts, Frequency, RTD's, TC's, Slidewires and DC Volts/Current and gives a proportional standard instrument output in mA dc or Volts dc

The **TSC series** are powered devices offering true 3 port galvanic isolation between input-output-power supply and provide a transmitted output that gives true zero output or any standard instrument signal in mA dc or mV / Volts dc.

FEATURES

- ◆ All standard inputs are link selectable
- ◆ Input monitor 0 - 10Vdc = 0 - 100%
- ◆ Full 3 Port galvanic isolation
- ◆ Externally accessible span/zero pot's (non-interactive)
- ◆ Plug off terminals for easy removal from service
- ◆ Two outputs as standard :- 0 to 10Vdc and a selected one (eg 4 - 20mA)
- ◆ Krilen housing non-combustible material
- ◆ Very small footprint area

DATA SHEET

Subject to change without notice

MODEL :- TSC-VC Powered Signal Conditioner V/C input

OPERATING CONTROLS & CONNECTIONS

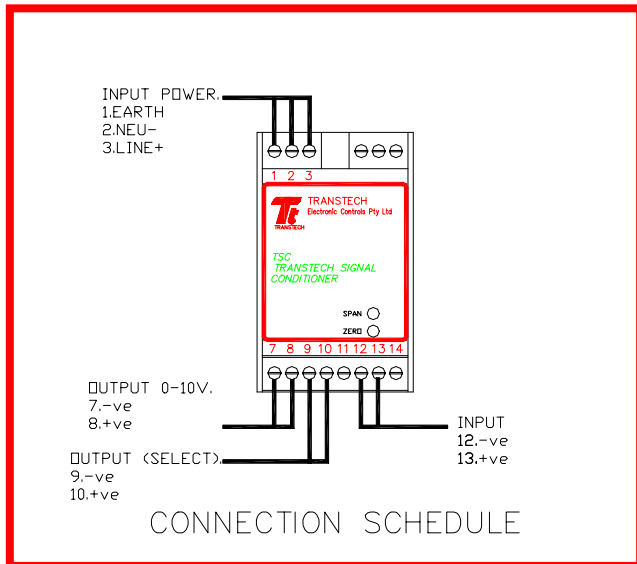

INTERNAL SETTINGS & CALIBRATION

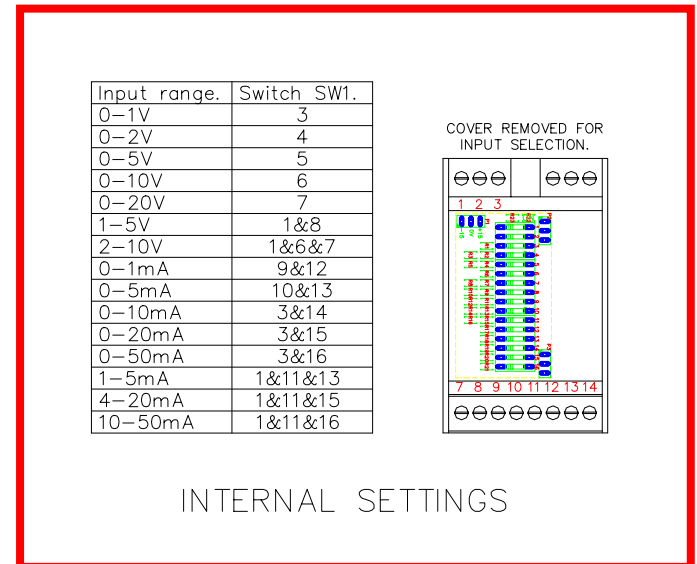

CALIBRATION & SET-UP INSTRUCTIONS:-

All **TransTech** signal conditioners are normally factory set to calibration details supplied by the customer. If field adjustments are necessary the following steps should be taken :-

1. Remove the top cover and set SW1 (range switch) to required input range from chart above.
2. Set the input signal to zero and adjust the signal zero adjustment potentiometer on top of the conditioner module to give 0.000Vdc at the monitor output.
3. Set the input signal to maximum and adjust the span potentiometer on top of the conditioner module to give 10.000Vdc at the 0 - 10 Vdc monitor output.

The unit is now fully calibrated as the span and zero adjustments are **not inter-reactive**.

If the optional range selection module is not fitted re-calibration can be done by AOT resistor changing, in this case contact the factory.