

**TKH-TOUCHb-FP**

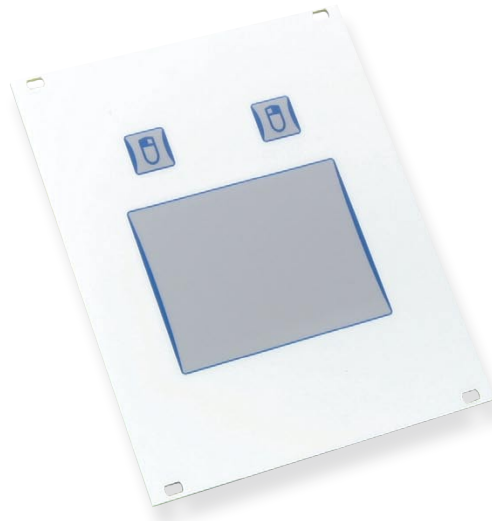

**www.esis.com.au**  
Ph 02 9481 7420  
Fax 02 9481 7267  
esis.enq@esis.com.au

**ESIS**  
Industrial Electronics

Esis Pty Ltd www.esis.com.au

**Features and benefits:**

- Capacitive Touchpad
- PS/2 and USB compatible
- Panel mount version
- Rugged construction for reliable functionality
- Chemical, abrasion and scratch resistant frontsheet
- Ergonomic design
- IP65 (NEMA 4x) frontside sealing
- Semi or full customisation available
- Cost-effective

**Specification**

Motion Detection Method: capacitive  
 Resolution: 40 counts / mm  
 Protection Level: IP65; NEMA 4x (frontside)  
 Mounting Type: panel mount  
 Dimensions: 110 x 135 x 20 mm; 4.330" x 5.314" x 0.787"  
 Weight: 150 grams  
 Operating Temperature: -40 °C to 90 °C; -40 °F to +194 °F  
 Frontpanel Material: PCB-material, FR4

Cat.-No.	Product Name	
KH02007	TKH-TOUCHb-FP-PS/2	PS/2
KH02008	TKH-TOUCHb-FP-USB	USB

## TKH-TOUCHb-FP

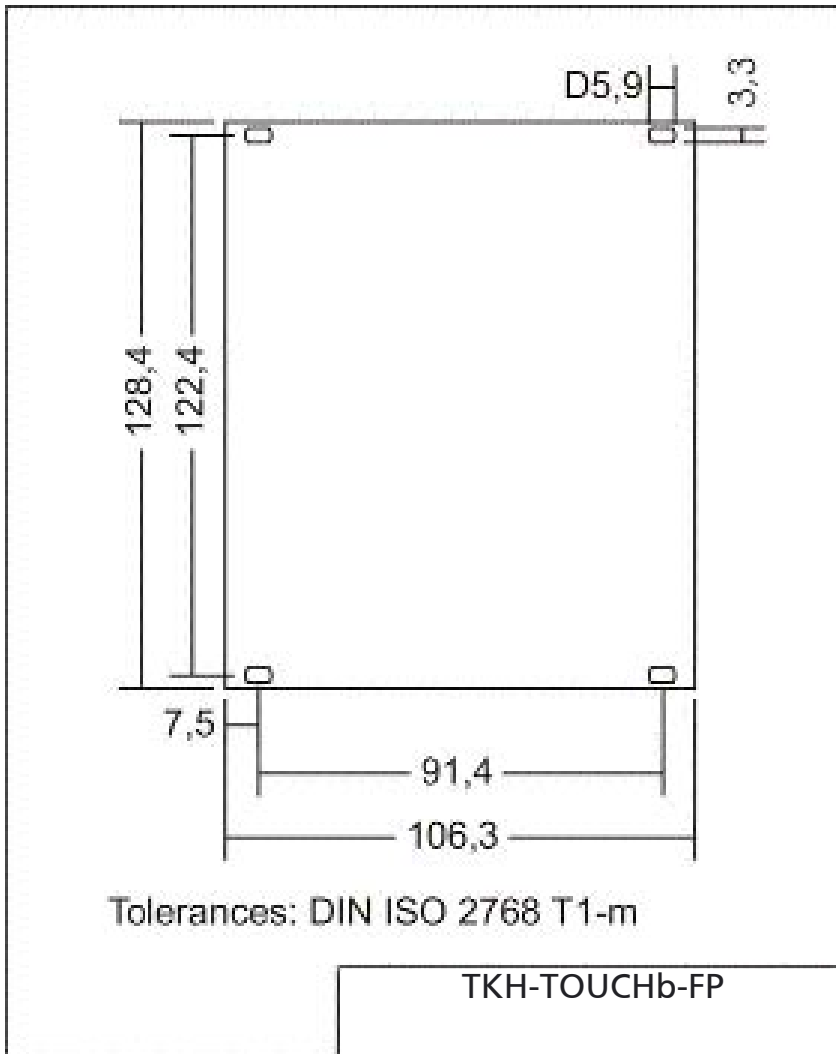

Mounting depth: 20 mm



**www.esis.com.au**  
Ph 02 9481 7420  
Fax 02 9481 7267  
esis.enq@esis.com.au

**ESIS**  
Industrial Electronics