

# HMP45A & HMP45D Relative Humidity and Temperature Probes; Solar Radiation Shield



The HMP45A and HMP45D humidity and temperature probes are excellent for measuring humidity in weather stations.

## Versatile probes

The Vaisala HUMICAP® Humidity and Temperature Probes HMP45A and HMP45D are designed for a wide range of instrumentation (e.g. recorders, data loggers, laboratory equipment and weather stations.)

The probes interface easily, are simple to service, operate from a wide range of supply voltages and consume little power.

The HMP45A/D is an excellent solution for measuring humidity in weather stations. However, the Vaisala HUMICAP® Humidity and Temperature Transmitter HMP337, with warmed sensor head, is a better solution if condensation continuously disturbs measurement.

## Vaisala HUMICAP® Sensor

The combined performance of the Vaisala HUMICAP® Sensor and IP65 (NEMA 4) protected probe provides accurate and repeatable humidity and temperature measurements in high humidity.

## Easy field maintenance

Field calibration is easy. The probe head containing the sensor and electronics can be quickly removed from the probe body, a replacement installed and the measurements continued while the other sensor head is calibrated in a laboratory.



The DTR503A shield provides protection from both scattered and direct solar radiation, and precipitation.

## On-site, one-point calibration

One-point calibration of relative humidity and temperature can be done in the field using Vaisala HUMICAP® Humidity Indicator HMI41.

## Shield protects sensor

Vaisala Radiation Shield DTR503A is a naturally ventilated, maintenance-free, 12 plate plastic shield that protects the humidity and temperature sensors from both scattered and direct solar radiation, and precipitation. The plastic material in the plates offers excellent thermal characteristics and UV stabilized construction. The white outer surface reflects radiation, while the black inside absorbs accumulated heat.

The shield is easy to install and is suitable for a wide range of applications. It can be installed on a vertical pole, horizontal beam, or flat surface.

DTR503A horizontal beam installation.

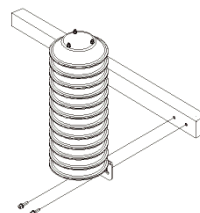

## Features/Benefits

- Vaisala HUMICAP® Humidity and Temperature Probes HMP45A/D provide up to 100 %RH with high accuracy
- Vaisala HUMICAP® Sensor for excellent accuracy, negligible hysteresis and long-term stability in high humidities, and is resistance to dust and most chemicals.
- Easy field calibration
- Vaisala Solar Radiation Shield DTR503A
- IP65 (NEMA 4) housing protects against dust, water spray, and electromagnetic interference.
- NIST traceable (certificate included)

## Dimensions

Dimensions in mm.

DTR503A  
for the HMP45A/D

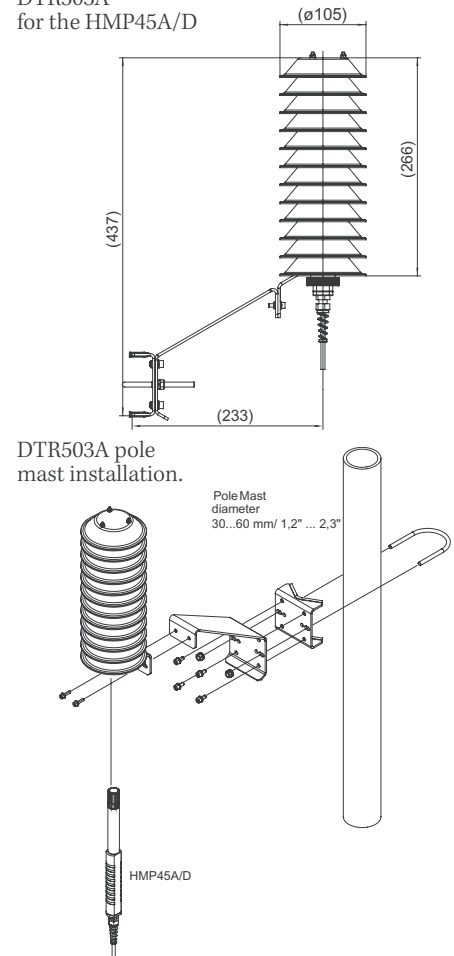

# Technical Data

## General

Operating temperature range	-40...+60 °C (-40...+140 °F)
Storage temperature range	-40...+80 °C (-40...+176 °F)
Supply voltage	7...35 VDC
Settling time	500 ms
Power consumption	<4 mA
Output load	>10kohm (to ground)
Weight	350 g (incl. package)
Cable length	3.5 m
Housing material	ABS plastic
Housing classification (electronics)	IP65
Sensor protection:	
standard: membrane filter	part no.2787HM
optional: grid	part no. 6597
Electromagnetic compatibility	Complies with EMC standard EN61326-1, Generic environment

## Relative humidity

### HMP45A & HMP45D

Measuring range:	0.8 to 100 %RH
Output scale	0...100 %RH equals 0...1 VDC
Accuracy at +20 °C (+68 °F) (incl. nonlinearity and hysteresis)	±1 %RH
against factory references	
field calibration against references	±2 %RH (0...90 %RH)
	±3 %RH (90...100 %RH)
Typical long-term stability	< 1% RH / year
Temperature dependence	±0.05 %RH/ °C (±0.03%RH/°F)
Response time (90% at +20 °C)	10 s with membrane filter
Humidity sensor	HUMICAP® 180

## Temperature

### HMP45A

Measurement range	-39.2...+60 °C (-39.2...+140 °F)
Output scale	-40...+60 °C (-40...+140 °F) equals 0...1 VDC
Accuracy at +20 °C (+68 °F)	±0.2 °C (±0.36 °F)

Accuracy over measurement range:

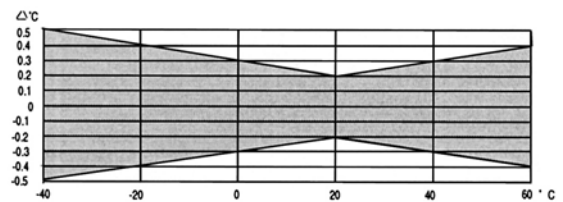

Temperature sensor

Pt 1000 IEC 751

### HMP45D

Measurement range	-40...+60 °C (-40...+140 °F)
Output signal	resistive four wire connection
Temperature sensor	Pt 100 IEC 751 1/3 Class B

## Dimensions

Dimensions in mm.

HMP45A/D connections

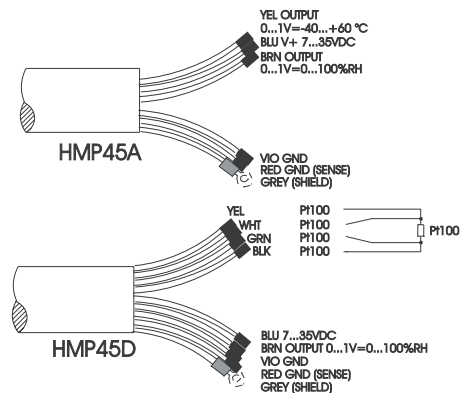

HMP45A/D probe

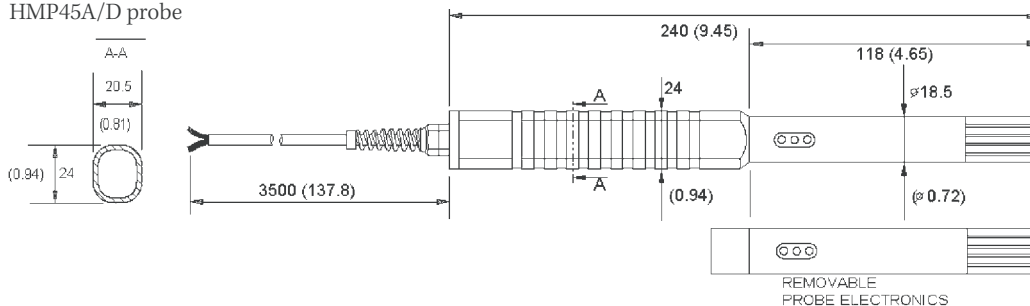

HUMICAP® is a registered trademark of Vaisala.  
 Specifications subject to change without prior notice.  
 ©Vaisala Oyj

