

HUMIDITY / DEW POINT /
MOISTURE IN OIL / CARBON DIOXIDE /
PRESSURE / WEATHER



VAISALA

HVAC
LUBRICATION

POWER
GENERATION

BUILDING
AUTOMATION

COMPRESSED AIR LIFE SCIENCE

ACCURATE

INSTRUMENTS CHAMBERS

HIGH-TECH
CLEANROOMS

RELIABLE

MEASUREMENTS

SERVICES

www.vaisala.com

VAISALA



We at Vaisala have always valued the opportunity to push ourselves and our products to a higher level for the benefit of our customers. Our new strategy nurtures this opportunity, allowing us to focus on customers who operate in tightly controlled and demanding areas in the chosen industrial applications introduced in this catalog. We are confident that concentrating Vaisala's product and business development efforts on these areas will result in the overall success of our customers.

The very core of Vaisala still is our unique devotion to products: the stability, reliability and performance that we have always been known and recognized for. With over 70 years of experience, close to 30 offices worldwide and thousands of customers in over 140 countries, Vaisala is an esteemed leader in innovating, manufacturing and servicing high-quality instruments and systems. Our products have been designed to meet the customers' measurement needs in the most demanding industrial processes and controlled environments. This catalog introduces Vaisala's measurement instrument offering for industrial customers. Our professional sales force all over the world is at your service, ready to help you choose just the right solution for your specific measurement needs.

I wish you every success with your business – we are at your service.

A handwritten signature in blue ink, appearing to read 'K. Fors', written in a cursive style.

*Kenneth Fors
Executive Vice President
Controlled Environment
Vaisala*

Go to www.vaisala.com for the latest updates and other product news.

Table of Contents by Parameters

Humidity

HMT330 Series Humidity and Temperature Transmitters for Demanding Humidity Measurement	4
HMT331 Humidity and Temperature Transmitter for Demanding Wall-Mounted Applications	8
HMT333 Humidity and Temperature Transmitter for Ducts and Tight Spaces	9
HMT334 Humidity and Temperature Transmitter for High Pressure and Vacuum Applications	10
HMT335 Humidity and Temperature Transmitter for High Temperatures	11
HMT337 Humidity and Temperature Transmitter for High Humidity Applications	12
HMT338 Humidity and Temperature Transmitter for Pressurized Pipelines	13
HMT360 Series Intrinsically Safe Humidity and Temperature Transmitters	14
HMT310 Humidity and Temperature Transmitter	20
HMT120 and HMT130 Humidity and Temperature Transmitters	22
HMW90 Series Humidity and Temperature Transmitters for High Performance HVAC Applications	24
HMD60/70 Humidity and Temperature Transmitters for Ducts in HVAC Applications	26
HMW80 Humidity and Temperature Transmitter Series	28
HMD42/53 Humidity and Temperature Transmitters for Ducts in Commercial HVAC Applications	30
HMM210 Series Humidity Modules for Environmental Chambers	32
HMM100 Humidity Module for Environmental Chambers	34
HMP60 Humidity and Temperature Probe	36
HMP110 Humidity and Temperature Probe	38
HM70 Hand-Held Humidity and Temperature Meter for Spot-Checking Applications	40
HMI41 Indicator and HMP42/HMP46 Probes	42
HM34 Pocket Size Relative Humidity Meter	46
SHM40 Structural Humidity Measurement Kit	48
HMK15 Humidity Calibrator	50
HMP155 Humidity and Temperature Probe	52
DTR500 Solar Radiation and Precipitation Shields	54
HMT330MIK Meteorological Installation Kit	56
HMT300TMK Turbine Mounting Kit for Power Turbine Intake Air Measurement	58

Dew Point

DMT340 Series Dewpoint and Temperature Transmitters for Very Dry Conditions	60
DMT345 and DMT346 Dewpoint Transmitters for High Temperature Applications	66
DMT242 Dewpoint Transmitter for OEM Applications	70
DMT152 Dewpoint Transmitter for Low Dewpoint Measurement in OEM Applications	72
DMT142 Miniature Dewpoint Transmitter for OEM Applications	74
DMT132 Dewpoint Transmitter for Refrigerant Dryers	76
DM70 Hand-Held Dewpoint Meter for Spot-Checking Applications	78
DSS70A Portable Sampling System and Sampling Cells for DM70	80
DPT146 Dewpoint and Pressure Transmitter for Compressed Air	82
DPT145 Multiparameter Transmitter for SF6 Gas	84
Dimensional Drawings of the DPT145 Multiparameter Transmitter	86

Moisture in Oil

MMT330 Moisture and Temperature Transmitter Series for Oil	88
MMT310 Series Moisture and Temperature Transmitter for Oil	94
MMT162 Compact Moisture in Oil and Temperature Transmitter for OEM Applications	96
MM70 Hand-Held Moisture and Temperature Meter for Spot-Checking in Oil	98

Carbon Dioxide

GMP343 Carbon Dioxide Probe for Demanding Measurements	100
GMT220 Series Carbon Dioxide Transmitters for Industrial Applications	102
GMM220 Carbon Dioxide Modules for Demanding OEM Applications	104
GMM111 Carbon Dioxide Module	106
GM70 Hand-Held Carbon Dioxide Meter for Spot-Checking Applications	108
GMW116 Carbon Dioxide and Temperature Transmitter for Ventilation Control	110
GMW115 Carbon Dioxide Transmitter for Demand-controlled Ventilation	112
GMD/W20 Series Carbon Dioxide Transmitters for Demand Controlled Ventilation Applications	114
GMM112 Carbon Dioxide Module for HVAC Applications	116
GMM20W Carbon Dioxide Module for OEM Applications	118

Pressure

PTU300 Combined Pressure, Humidity and Temperature Transmitter for Demanding Applications	120
PTB330 Digital Barometer for Professional Meteorology, Aviation, and Industrial Users	126
PTB330TS Barometric Pressure Transfer Standard - Take the Lab to the Field	128
PTB330TS Barometric Pressure Transfer Standard	130
PTB210 Digital Barometer	132
PTB110 Barometer for Industrial Use	136
SPH10/20 Static Pressure Heads for Minimizing Wind Induced Error	138
PDT102 Differential Pressure Transmitter	140
PDT101 Differential Pressure Transmitter	142

Weather

WXT520 Weather Transmitter Access to Real Time Weather Data	144
WMT52 Ultrasonic Wind Sensor for Accurate and Stable Measurement	146
WA15 Wind Set for High Performance Wind Measurement	148

Vaisala Service Offering

Vaisala Service Offering	150
Calibration is Our Core Operation	151
Vaisala Filters	152
Vaisala Contact Information	156

HMT330 Series Humidity and Temperature Transmitters for Demanding Humidity Measurement



Features/Benefits

- Six models for demanding industrial applications
- Full 0 ... 100 % RH measurement, temperature range up to +180 °C (+356 °F) (depending on model)
- Pressure tolerance up to 100 bar (depending on model)
- Next generation Vaisala HUMICAP® Sensor for excellent accuracy and stability
- Graphical display of measurement trends and over four-year history
- Multilingual user interface
- Excellent performance in harsh chemical concentrations
- Corrosion resistant IP65 housing
- NIST traceable (certificate included)
- Analog outputs, WLAN/LAN
- MODBUS protocol support (RTU/TCP)

The HMT330 transmitter family has the solution for demanding industrial humidity measurements.

The Vaisala HUMICAP® Humidity and Temperature Transmitter Series HMT330 is designed for demanding industrial applications where stable measurement and wide customization is important.

Vaisala HUMICAP® Performance

The HMT330 series incorporates Vaisala's 30 years of experience in industrial humidity measurement. An updated, even more stable and chemical resistant HUMICAP® sensor is available, next to the proven reliable and accurate sensor.

Chemical Purge Minimizes Effects of Contaminants

In environments with high concentrations of chemicals and cleaning agents, chemical purge option helps to maintain measurement accuracy between calibration intervals.

Chemical purge involves heating the sensor to remove harmful chemicals. The function can be initiated manually or programmed to occur at set intervals.



Graphical Display of History and Measurement Trends

The HMT330 can be ordered with a large numerical and graphical display, which allows the user to clearly monitor operational data, measurement trends and 1-year measurement history. The optional data logger with real-time clock makes it possible to generate over four years of measured history, and zoom in on any desired time or time frame. The battery backup of the clock guarantees a reliable logging of measured data.

The display alarm allows tracking of any measured parameter, with a freely configurable low and high limit.

Data Collection and (Wireless) Transfer to PC

The recorded measurement data can be viewed on the display or transferred to a PC with Microsoft Windows® software. The transmitter can also be connected to a network with an optional (W)LAN interface, which enables a (wireless) Ethernet connection. A USB-RJ45 cable makes it easy to connect the service port of the HMT330 to a PC.

Many Ways to Install and Versatile Outputs

Mains and DC power options, and several mounting accessories make the instrument easy to install.

The HMT330 can have up to three analog outputs. Isolated galvanic power supply and relay outputs are also available. For serial interface the

USB connection, RS232 and RS485 can be used.

HMT330 is also capable in applying the MODBUS communication protocol and together with an appropriate connection option provides either MODBUS RTU (RS485) or MODBUS TCP/IP (Ethernet) communication.

Flexible Calibration

The HMT330 instruments are calibrated at six humidity points at the factory. A quick, one-point field calibration can be performed with the hand-held HM70 meter.

A two-point **field** calibration can be performed with the HMK15 salt bath calibrator in a controlled environment. The transmitter can be sent to Vaisala for recalibration. Accredited calibrations and maintenance contracts are also available.

Technical Data

Performance

RELATIVE HUMIDITY

Measurement range	0 ... 100 % RH
Accuracy (including non-linearity, hysteresis, and repeatability)	
with Vaisala HUMICAP® 180 or 180R	for typical applications
with Vaisala HUMICAP® 180C or 180RC	for applications with chemical purge/warmed probe
at +15 ... +25 °C (59 ... +77 °F)	±1 %RH (0 ... 90 %)
	±1.7 %RH (90 ... 100 %RH)
at -20 ... +40 °C (-4 ... +104 °F)	±(1.0 + 0.008 x reading) %RH
at -40 ... +180 °C (-40 ... +356 °F)	±(1.5 + 0.015 x reading) %RH
Factory calibration uncertainty (+20 °C)	± 0.6 % RH (0 ... 40 %RH)
	± 1.0 % RH (40 ... 97 %RH)

(Defined as ±2 standard deviation limits. Small variations possible, see also calibration certificate.)

Response time (90 %) at +20 °C (+68 °F)	8 s / 17 s* with grid filter
in still air	20 s / 50 s* with grid + steel netting filter
	40 s / 60 s* with sintered filter

* with HUMICAP® 180R or 180RC sensor

TEMPERATURE

Accuracy at +20 °C (+68 °F)	± 0.2 °C (± 0.36 °F)
Accuracy over temperature range (measurement range depends on model)	

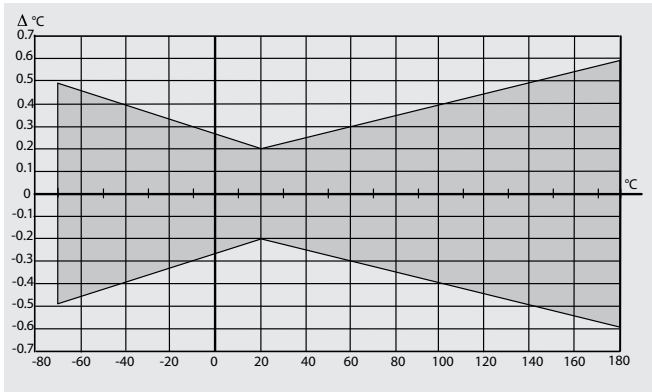

Temperature sensor PT 100 RTD 1/3 Class B IEC 751

Other variables available (depends on model)

dewpoint temperature, mixing ratio, absolute humidity, wet bulb temperature, enthalpy, water vapor pressure

Inputs and Outputs

Operating voltage	10 ... 35 VDC, 24 VAC
with optional power supply module	100 ... 240 VAC, 50/60 HZ
Power consumption at +20 °C (U _{in} 24 VDC)	
RS-232	max. 25 mA
U _{out} 2 x 0 ... 1 V/0 ... 5 V/0 ... 10 V	max. 25 mA
I _{out} 2 x 0 ... 20 mA	max. 60 mA
display and backlight	+ 20 mA
during chemical purge	max. 110 mA
during probe heating (HMT337)	+ 120 mA
Analog outputs (2 standard, 3rd optional)	
current output	0 ... 20 mA, 4 ... 20 mA
voltage output	0... 1 V, 0... 5 V, 0... 10 V
Accuracy of analog outputs at +20 °C	±0.05% full scale
Temperature dependence of the analog outputs	±0.005%/°C full scale
External loads	
current outputs	R _L < 500 ohm
0 ... 1 V output	R _L > 2 kohm
0 ... 5 V and 0 ... 10 V outputs	R _L > 10 kohm
Max. wire size	0.5 mm ² (AWG 20)
	stranded wires recommended
Digital outputs	RS-232, RS-485 (optional)
Protocols	ASCII commands, MODBUS RTU
Service connection	RS-232, USB
Relay outputs (optional)	0.5 A, 250 VAC
Ethernet interface (optional)	
Supported standards	10BASE-T, 100BASE-TX
Connector	8P8C (RJ45)
IPv4 address assignment	DHCP (automatic), static
Protocols	Telnet, MODBUS TCP/IP
WLAN interface (optional)	
Supported standards	802.11b
Antenna connector type	RP-SMA
IPv4 address assignment	DHCP (automatic), static
Protocols	Telnet, MODBUS TCP/IP
Security	WEP 64/128, WPA2/802.11i
Authentication / Encryption (WLAN)	
Open / no encryption	
Open / WEP	
WPA Pre shared key / TKIP	
WPA Pre shared key / CCMP (a.k.a. WPA2)	
Optional data logger with real-time clock	
Logged parameters	max. four with trend/min/max values
Logging interval	10 sec (fixed)
Max. logging period	4 years 5 months
Logged points	13.7 million points per parameter
Battery lifetime	min. 5 years
Display	LCD with backlight, graphic trend display of any parameter
Menu languages	English, Chinese, Japanese, Spanish, German, French, Swedish, Russian, Finnish

Mechanics

Cable bushing	M20 x 1.5 for cable diameter 8 ... 11 mm/0.31 ... 0.43"
Conduit fitting	1/2" NPT
User cable connector (optional)	M12 series 8-pin (male)
option 1	female plug with 5 m (16.4 ft) black cable
option 2	female plug with screw terminals
Probe cable diameter	
HMT333 (+80 °C)	6.0 mm
other probes	5.5 mm
Housing material	G-AlSi 10 Mg (DIN1725)
Housing classification	IP 65 (NEMA4)

Operating Environment

Operating temperature	
for probe	same as measurement range
for transmitter body	-40 ... +60 °C (-40 ... 140 °F)
with display	0 ... +60 °C (32 ... 140 °F)
Electromagnetic compatibility	Complies with EMC standard EN61326-1, Industrial Environment

Mounting Options



Mounting with Wall
Mounting Kit



Mounting with DIN Rail
Installation Kit



Pole Installation with Installation
Kit for Pole or Pipeline



Mounting Rain Shield with
Installation Kit

Dimensions

Dimensions in mm (inches)

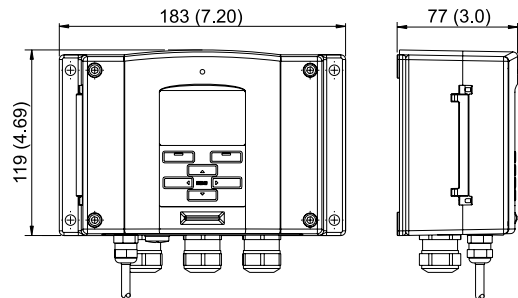

Transmitter with WLAN antenna

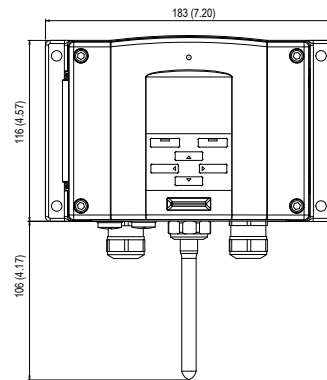

VAISALA

For more information, visit
www.vaisala.com or contact
us at sales@vaisala.com

Ref. B210951EN-C ©Vaisala 2011

This material is subject to copyright protection, with all copyrights retained by Vaisala and its individual partners. All rights reserved. Any logos and/or product names are trademarks of Vaisala or its individual partners. The reproduction, transfer, distribution or storage of information contained in this brochure in any form without the prior written consent of Vaisala is strictly prohibited. All specifications — technical included — are subject to change without notice.



TYPE APPROVED PRODUCT
CERTIFICATE NO.: A-11440



HMT331 Humidity and Temperature Transmitter for Demanding Wall-Mounted Applications



HMT331 Humidity and Temperature Transmitter with short flexible probe and optional WLAN.

The HMT331 is the state-of-the-art wall-mount humidity instrument.

Features/Benefits

- For temperatures -40 ... +60 °C (-40 ... +140 °F)
- Application examples: cleanrooms, pharmaceutical processes, greenhouses, swimming halls, museums and archives

The Vaisala HUMICAP® Humidity and Temperature Transmitter HMT331 is the top-of-the-line wall-mounted transmitter for demanding HVAC and condition monitoring applications. Compared to regular wall-mounted transmitters, the HMT331 offers, higher measurement performance, better chemical tolerance, advanced graphical display features, more powering options, more output options and a wider variety of output humidity parameters.

Graphical Display of History and Measurement Trends

The HMT330 series features a large numerical and graphical display, allowing users to easily monitor operational data, measurement trends and one-year measurement history. The optional data logger with real-time clock makes it possible to generate over four years of measured history, and zoom in on any desired time or time frame.

Outputs and Power Supply Options for Every Need

The output options include three analog outputs, RS-232, RS-485, and alarm relays.

The voltage supply range is from 10 to 35 VDC. With an additional module, the transmitter can be connected to all universal mains AC supplies.

The input/output cable can be fed through the back of the transmitter, which is a useful feature, especially for installations in cleanrooms.

Technical Data

Temperature measurement range
-40 ... +60 °C (-40 ... +140 °F)

Accessories

PC software + cable	215005
USB-RJ45 Serial Connection Cable	219685
Connection cable for HM70	211339
Wall mounting plate (plastic)	214829
Pole installation kit	215108
Rain shield	215109
DIN rail installation set	215094

Dimensions

Dimensions in mm (inches)

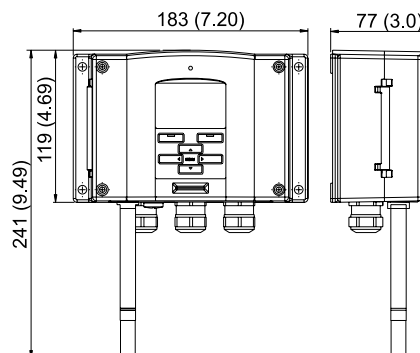

HMT333 Humidity and Temperature Transmitter for Ducts and Tight Spaces



The HMT333 transmitter has a small probe for remote applications.



210697 duct installation kit for HMT333 and HMT337.

For outdoor environments, the DTR502B solar radiation shield provides protection for the probe. The shield can be installed on a pole, a beam or a flat surface.

For Moderate Humidities and Temperatures

The HMT333 is typically used in demanding HVAC applications such as cleanrooms, pharmaceutical processes, and greenhouses, or in processes of moderate temperature.

For environments with continuously high humidity, the HMT337 with a warmed, vapor-tight and stainless steel probe is recommended.

Features/Benefits

- For remote probe installations in demanding HVAC applications
- For temperatures -40 ... +80 °C (-40 ... +176 °F) or -40 ... +120 °C (-40 ... +248 °F)
- Small thermal mass - fast response to temperature changes
- Application examples: cleanrooms, pharmaceutical processes, greenhouses, environmental chambers

The Vaisala HUMICAP® Humidity and Temperature Transmitter HMT333 is a versatile instrument for applications where a small remote probe is needed.

Flexible Installation

To install the probe in ducts, channels and through walls, an installation kit is available with a stainless steel flange, lead-through piece, and steel support bar.

HMT333 has two probe cable options available, a flexible one that withstands heat up to +80° C, and a durable cable that withstands heat up to +120° C. Both cable options are available in lengths of 2, 5, and 10 meters.

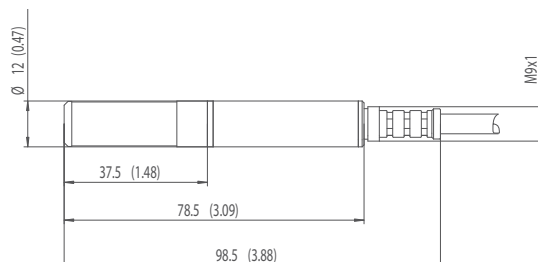

Technical Data

Temperature measurement range
 -40 ... +80 °C (-40 ... +176 °F) or
 -40 ... +120 °C (-40 ... +248 °F)

Accessories

Duct installation kit	210697
Cable gland	HMP247CG
PC software + cable	215005
USB-RJ45 Serial Connection Cable	219685
Connection cable for HM70	211339
Wall mounting plate (plastic)	214829
Pole installation kit	215108
Rain shield	215109
Solar radiation shield	DTR502B
DIN rail installation set	215094

Dimensions

Dimensions in mm (inches)

HMT334 Humidity and Temperature Transmitter for High Pressure and Vacuum Applications



The display shows measurement trends and over four-year real time measurement history.

The HMT334 is ideal for permanent installations into pressurized or vacuum processes.

Features/Benefits

- For pressures up to 100 bar and vacuum applications
- For temperatures -70 ... +180 °C (-94 ... +356 °F)
- ISO and NPT threads available
- Application example: test chambers

Technical Data

Temperature measurement range	-70 ... +180 °C (-94 ... +356 °F)
Operating pressure	0 ... 10 MPa (0 ... 100 bar)

Accessories

Fitting body ISO M22 x 1.5	210697
Fitting body NPT 1/2"	17225
PC software + cable	215005
USB-RJ45 Serial Connection Cable	219685
Connection cable for HM70	211339
Wall mounting plate (plastic)	214829
Pole installation kit	215108
Rain shield	215109
DIN rail installation set	215094

Dimensions

Dimensions in mm (inches)

The Vaisala HUMICAP® Humidity and Temperature Transmitter HMT334 is designed to measure humidity in pressurized spaces or vacuum chambers. Each probe is tested to ensure a gas and vacuum tight installation.

Vaisala HUMICAP® Performance

The HMT334 incorporates Vaisala's more than 30 years of experience in industrial humidity measurement. The sensor provides accurate and reliable measurement and is immune to particulate contamination and most chemicals.

Graphical Display of Measurement Trends and Real Time History

The HMT330 series features a numerical and graphical display. The user can easily monitor operational data, measurement trends and up to one-year history.

The optional data logger with real-time clock makes it possible to generate more than four years of measured history, and zoom in on any desired time or time frame.

Using a serial line, the measurement data can be transferred to a PC where it can be further processed and copied to other programs.

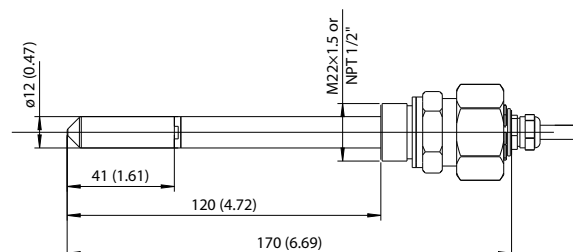

HMT335 Humidity and Temperature Transmitter for High Temperatures



The installation flange allows an adjustable installation depth for the probe.

The HMT335 has a robust stainless steel probe ideal for high flow rates in hot processes.

Features/Benefits

- For temperatures -70 ... +180 °C (-94 ... +356 °F)
- Long metal probe head
- Stainless steel installation flange available
- Adjustable installation depth
- Application example: hot drying processes

The Vaisala HUMICAP® Humidity and Temperature Transmitter HMT335 has a long stainless steel probe designed for high temperatures.

Robust Probe Ideal for High Flow Rates

The HMT335 is ideal for duct measurements as the probe tolerates mechanical stress and withstands high flow rates. The HMT335 can be used, for example, in a hot drying process.

monitor measurement operational data, measurement trends and one-year measurement history.

The optional data logger with real-time clock makes it possible to generate more than four years of measured history, and zoom in on any desired time or time frame.

Vaisala HUMICAP® Performance

The sensor provides accurate and reliable measurement and is immune to particulate contamination and most chemicals.

Technical Data

Temperature measurement range
-70 ... +180 °C (-94 ... +356 °F)

Accessories

Mounting flange	210696
PC software + cable	215005
USB-RJ45 Serial Connection Cable	219685
Connection cable for HM70	211339
Wall mounting plate (plastic)	214829
Pole installation kit	215108
Rain shield	215109
DIN rail installation set	215094

Dimensions

Dimensions in mm (inches)

Graphical Display of History and Measurement Trends

The HMT335 features a numerical and graphical display. The user can easily

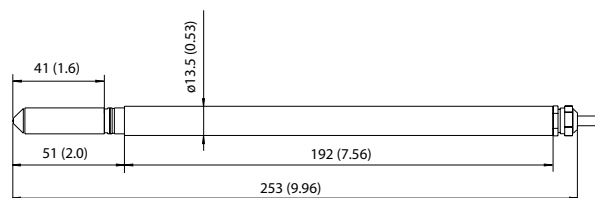

HMT337 Humidity and Temperature Transmitter for High Humidity Applications



The HMT337 is the ideal transmitter for the most demanding process and meteorological measurements.



Duct installation kit

Features/Benefits

- For high-humidity applications in industry and meteorology
- Warmed probe for superior performance in condensing environments
- Small, stainless steel, vapor-tight remote probe
- For temperatures -70 ... +180 °C (-94 ... +356 °F)

Technical Data

Temperature measurement range
-70 ... +180 °C (-94 ... +356 °F)

Accessories

Cable gland and AGRO	HMP247CG
Duct installation kit (RH probe)	210697
Duct installation kit (T probe)	215003
Swagelok fittings (NPT and ISO) for both RH and T probes	
Solar radiation shield	DTR502B
Meteorological inst. kit	HMT330MIK
PC software + cable	215005
USB-RJ45 Serial Connection Cable	219685
Connection cable for HM70	211339
Wall mounting plate (plastic)	214829
Pole installation kit	215108
Rain shield	215109
DIN rail installation set	215094

Dimensions

Dimensions in mm (inches)

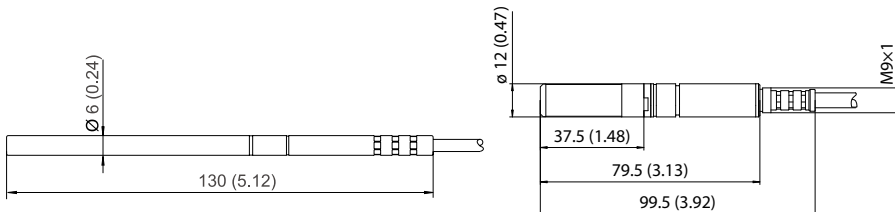

The Vaisala HUMICAP® Humidity and Temperature Transmitter HMT337 is delivered in one of three configurations:

- Basic: non-warmed probe for moderate humidities
- With a warmed probe: for near-condensing conditions and dew point measurement
- With a warmed probe and an additional temperature sensor: for near-condensing conditions and relative humidity measurement

True Humidity Readings in Conditions of Condensation

The Vaisala unique warmed probe provides fast and reliable

measurement in environments where humidity is near saturation. The warming prevents condensation from forming on the sensor.

As the probe is warmed, the humidity level inside it stays below the ambient level. With accurate temperature measurement, the ambient dewpoint can be calculated precisely.

If the relative humidity value is needed, an additional temperature sensor is used. The measured ambient temperature provides the compensation for calculating relative humidity and other humidity parameters.

Many Ways to Install

A tight installation through a process wall can be achieved with Swagelok® fittings. Meteorological installation kits for outdoor installations and duct installation kits are also available.

HMT338 Humidity and Temperature Transmitter for Pressurized Pipelines



The HMT338 is ideal for installations in pressurized processes where the probe needs to be removed while the process is running.

Features/Benefits

- Installed through ball valve
- can be inserted and removed while the process is running
- Adjustable probe depth
- Pressure tolerance 40 bar
- For temperatures
-70 ... +180 °C (-94 ... +356 °F)
- Two probe lengths available

The Vaisala HUMICAP® Humidity and Temperature Transmitter HMT338 is designed for pressurized processes.

Insert or Remove Probe While the Process is Running

With “hot tapping”, the probe is inserted directly into the process while it is running, without the need for venting or lowering the process pressure.

The probe is screwed into a ball valve assembly that has been fixed to the process pipe or wall. The adjustable hex nut is hand-tightened to temporarily hold the probe to the process. Then the probe is pushed

down to the appropriate depth. The hex nut is tightened with a wrench to lock the probe in its place. Hot tapping is possible in pressures up to 10 bar.

Graphical Display of History and Measurement Trends

From the display, the user can easily monitor operational data, measurement trends and one-year measurement history.

The optional data logger with real-time clock makes it possible to generate more than four years of measured history, and zoom in on any desired time or time frame. The battery backup of the real-time clock guarantees a reliable logging of measured data.

Vaisala HUMICAP®

The HMT338 incorporates Vaisala's more than 30 years of experience in industrial humidity measurement. The sensor provides accurate and reliable measurement and is immune to particulate contamination and most chemicals.

Technical Data

Temperature measurement range	-70 ... +180 °C (-94 ... +356 °F)
Operating pressure	0 ... 4MPa (0 ... 40 bar)

Accessories

Ball valve set	BALLVALVE-1
Pressure fitting ISO 1/2 to NPT 1/2	210662
PC software + cable	215005
USB-RJ45 Serial Connection Cable	219685
Connection cable for HM70	211339
Wall mounting plate (plastic)	214829
Pole installation kit	215108
Rain shield	215109
DIN rail installation set	215094

Dimensions

Dimensions in mm (inches)

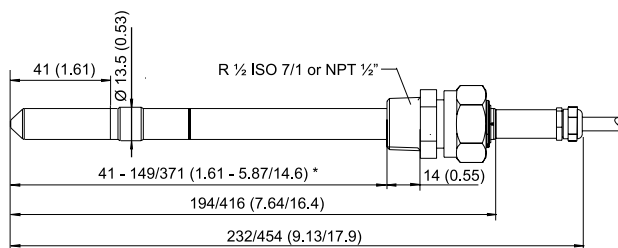

Lengths for standard / optional probes
* freely user-adjustable length

HMT360 Series Intrinsically Safe Humidity and Temperature Transmitters



The Vaisala HUMICAP® Humidity and Temperature Transmitter HMT361 wall mount transmitter, shown with six probe options, is designed specifically for hazardous and explosive environments.

Features/Benefits

- Measures humidity and temperature, outputs also dewpoint, mixing ratio, absolute humidity and wet bulb temperature
- Safe operation with the entire transmitter in hazardous areas: Division 1 and 2 (USA, Canada), Categories 1G / Zone 0 and 1D / Zone 20 with protection cover (EU)
- Intrinsically safe
- Designed for harsh conditions
- Vaisala HUMICAP® Sensor features high accuracy, excellent long-term stability, and negligible hysteresis
- Six probe options
- Temperature range between -40 ... +180°C (-40 ... +356°F) depending on the probe option
- NIST traceable (certificate included)

The Vaisala HUMICAP® Humidity and Temperature Transmitter Series HMT360 are the ideal solution for measuring humidity in hazardous areas. They operate safely and reliably even in the most hazardous classifications. The HMT360 transmitters' proven performance and technology conform with rigorous international standards.

Intrinsically safe

The entire HMT360 transmitter can be installed directly in explosive areas. It can withstand continuous exposure to potentially explosive environments that contain flammable gases or dust.

Customized Configuration

Due to the microprocessor based electronics, options and accessories, the HMT360 series is truly flexible.

Customers may specify the transmitter configuration when ordering the instrument, however changes in configuration can also easily be made in the field.

Interchangeable Probes

The HMT360 offers six probe options for various applications:

HMP361	- wall mount
HMP363	- confined spaces
HMP364	- pressurized spaces
HMP365	- high temperature
HMP367	- high humidity
HMP368	- pressurized pipelines

The interchangeable probes enable fast and easy removal or re-installation when required. Calibration, for example, is easy to perform due to the modular structure. All calibration coefficients are included in the probe unit itself, which means that probes can be switched between transmitter bodies without losing the accuracy.

Optimized Sensors

In addition to the standard Vaisala HUMICAP® Sensor, an application specific, very chemically durable sensor is also available.

Long-term solution

The HMT360 transmitters are an investment; their rugged design, combined with trouble-free operation, ensure a long-term solution for monitoring humidity and dewpoint in explosive environments.

Customized calibration and maintenance contracts for the HMT360 series are available on request.



Interchangeable Probes for HMT360 Intrinsically Safe Humidity and Temperature Transmitter



The HMP361 probe in this picture has a stainless steel netting filter.

Technical Data

HMP361 for wall mounting

Temperature range	-40 ... +60 °C (-40 ... +140 °F)
Probe diameter	12 mm

Dimensions

Dimensions in mm (inches)

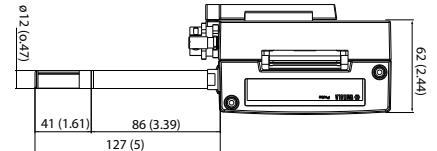

The HMP363 probe is small and fits into tight spaces. This one is connected with a teflon cable.

Technical Data

HMP363 for confined spaces

Temperature range with teflon cable	-40 ... +120 °C (-40 ... +248 °F)
Temperature range with rubber cable	-40 ... +80 °C (-40 ... +176 °F)

Probe cable length	2, 5 or 10 meters
Probe diameter	12 mm

Installation

Duct installation kit	210697
Cable Gland M20x1.5 with splitting seal	HMP247CG
Swagelok for 12mm probe, 1/2" NPT thread	SWG12NPT12

Dimensions

Dimensions in mm (inches)

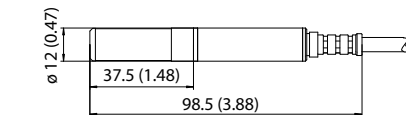

Installation kit for duct mounting

Installation flange: aluminum or stainless steel

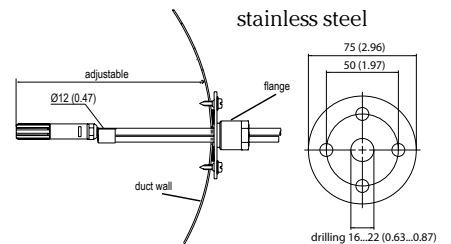

The HMP364 probe is designed for measurement in pressurized spaces or vacuum chambers.

Technical Data

HMP364 for high pressure

Temperature range	-40 ... +180 °C (-40 ... +356 °F)
Pressure range	0 ... 10 MPa
Probe cable length	2, 5 or 10 meters
Probe diameter	12 mm
Fitting body M22x1.5	17223
Fitting body NPT1/2	17225

Dimensions

Dimensions in mm (inches)

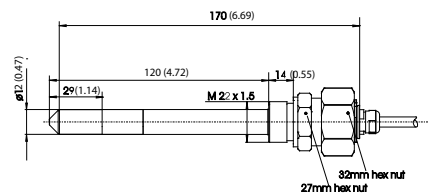



The HMP365 probe is designed for high temperature environments.

Technical Data

HMP365 for high temperature

Temperature range	-40 ... +180 °C (-40 ... +356 °F)
Probe cable length	2, 5 or 10 meters
Probe diameter	13.5 mm
Installation	
Mounting flange	210696
Cable Gland M20x1.5 with splitting seal	HMP247CG

Dimensions

Dimensions in mm (inches)

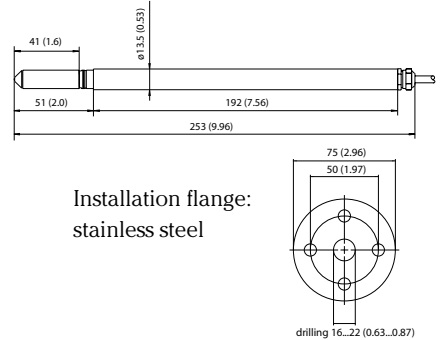

Installation flange:
stainless steel



The HMP367 probe is constructed to be installed in environments with high humidities.

Technical Data

HMP367 for high humidities

Temperature range	-40 ... +180 °C (-40 ... +356 °F)
Probe cable length	2, 5 or 10 meters
Probe diameter	12 mm
Installation	
Duct installation kit	210697
Cable Gland M20x1.5 with splitting seal	HMP247CG
Swagelok for 12mm probe, 3/8" ISO thread	SWG12ISO38
Swagelok for 12mm probe, 1/2" NPT thread	SWG12NPT12

Dimensions

Dimensions in mm (inches)

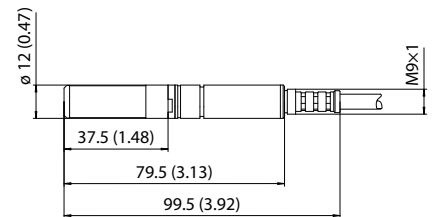

The HMP368 probe enables flexible installation in pressurized pipelines.

Technical Data

HMP368 for pressurized pipelines

Temperature range	-40 ... +180 °C (-40 ... +356 °F)
Pressure range	0 ... 4 MPa
Probe cable length	2, 5 or 10 meters
Probe diameter	13.5 mm/12 mm
Two probe lengths available.	
Installation	
Fitting body ISO1/2 solid structure	DRW212076SP
Fitting body NPT1/2 solid structure	NPTFITBODASP
Ball valve ISO 1/2 with welding joint	BALLVALVE-1

Dimensions

Dimensions in mm (inches)

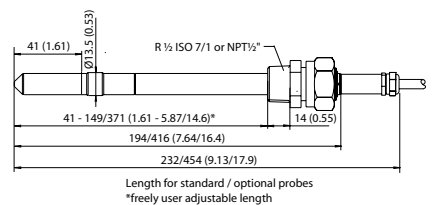

Technical Data

Performance

RELATIVE HUMIDITY

Measurement range 0 ... 100 %RH

Accuracy (including non-linearity, hysteresis, and repeatability)

with Vaisala HUMICAP® 180 or 180R for typical applications

at +15 ... +25 °C (59 ... +77 °F) ± 1.0 %RH (0 ... 90 %RH)

± 1.7 %RH (90 ... 100 %RH)

at -20 ... +40 °C (-4 ... +104 °F) ± (1.0 + 0.008 x reading) %RH

at -40 ... +180 °C (-40 ... +356 °F) ± (1.5 + 0.015 x reading) %RH

with Vaisala HUMICAP® 180₂ for application with demanding chemical environment

at -10... +40 °C (14 ... +104 °F) ± (1.0 + 0.01 x reading) %RH

at -40 ... +180 °C (-40 ... +356 °F) ± (1.5 + 0.02 x reading) %RH

Factory calibration uncertainty (+20 °C) ± 0.6 %RH (0 ... 40 %RH)

± 1.0 %RH (40 ... 97 %RH)

(Defined as ±2 standard deviation limits. Small variations possible, see also calibration certificate.)

Response time (90 %) at +20 °C (+68 °F) in still air

with grid filter 8 s / 17 s*

with grid + steel netting filter 20 s / 50 s*

with sintered filter 40 s / 60 s*

* with HUMICAP® 180R sensor

TEMPERATURE

Measurement range -40 ... +180 °C (-40 ... +356 °F)

(depends on selected probe)

Typical accuracy of electronics at +20 °C (+68 °F) ± 0.2 °C (0.36 °F)

Typical temperature dependence of electronics

0.005 °C/°C (0.005 °F/°F)

Sensor Pt 1000 RTD 1/3 Class B IEC 751

Accuracy over temperature range

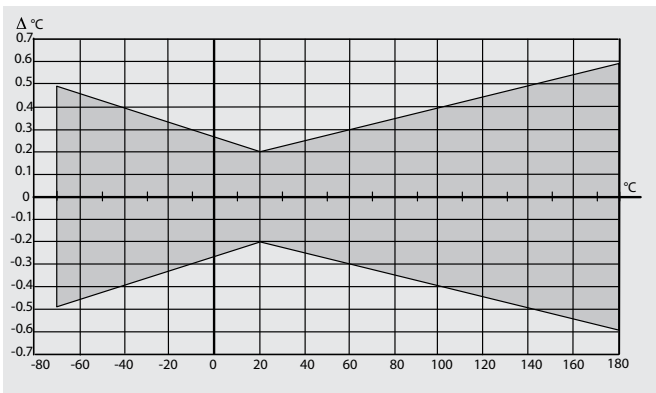

OTHER VARIABLES

Optionally available dewpoint temperature, mixing ratio, absolute humidity, wet bulb temperature.

Operating Environment

Temperature range

operating temp. range for

electronics -40 ... +60 °C (-40 ... +140 °F)

with display -20 ... +60 °C (-4 ... +140 °F)

storage -40 ... +70 °C (-40 ... +158 °F)

Pressure range

see probe specifications

Complies with EMC standard EN61326-1, Electrical equipment for measurement, control and laboratory use - EMC requirements; Industrial Environment.

NOTE! IEC 1000-4-5 complies only when using external EXi approved surge arrester in the safe area.

Inputs and Outputs

Operating voltage 12 ... 28 V

with serial port (service mode) 15 ... 28 V

Analog outputs two-wire 4 ... 20 mA, one standard, one optional

Typical accuracy of analog outputs at +20 °C ± 0.05% full scale

Typical temperature dependence

of analog outputs 0.005% / °C (0.005% / °F) full scale

Analog outputs connection via safety barriers

RS232C serial output for service use connector type RJ45

Display two-line LCD

Mechanics

Connections screw terminals, 0.33...2.0 mm

2 wires (AWG 14-22)

Cable bushings For 7.5...12mm or 10...15mm cable

diameters (M20)

Conduit fitting NPT 1/2" (M20)

Housing material G-AIS₁10Mg (DIN 1725)

Housing classification IP66 (NEMA 4X)

Housing weight 950 g

Options and Accessories

Duct installation kit (for HMP363/367) 210697

Mounting flange (for HMP365) 210696

Ball valve ISO 1/2 with welding joint BALLVALVE-1

(for HMP368)

pressure range at +20 °C (+68 °F): 0 ... 20 bar (0 ... 290 psia)

(during installation max. 10 bar (145 psia))

Calibration adapter for HMK15 211302

Serial interface cable for PC

connectors RJ45 - D9 female 25905ZZ

Galvanic isolator 212483

Zener barrier (USA & Canada) 210664

Protection cover (for use in the presence of combustible dust, ATEX) 214101

II 1 D IP65 T = 70 °C

Classification with Current Outputs

EUROPE / VTT

EU (94/9/EC, ATEX100a) II 1 G Ex ia IIC T4 Ga

VTT 09 ATEX 028 X issue No: 1

Safety factors $U_i = 28 \text{ V}$, $I_i = 100 \text{ mA}$, $P_i = 700 \text{ mW}$
 $C_i = 1 \text{ nF}$, L_i negligibly low

Environmental specifications

T_{amb} -40 ... +60 °C (-40 ... +140 °F)

P_{amb} 0.8 ... 1.1 bar

Dust classification (with protection cover) II 1 D (IP65 $T=70 \text{ °C}$)

VTT 04 ATEX 023X

USA (FM) Classes I, II, III, Division 1, Groups A-G and
 Division 2, Groups A-D, F and G
 FM Project ID: 3010615

Safety factors: $V_{max} = 28 \text{ VDC}$, $I_{max} = 100 \text{ mA}$,
 $C_i = 1 \text{ nF}$, $L_i = 0$, $P_i = 0.7 \text{ W}$, $T_{amb} = 60 \text{ °C}$ (140 °F), T5

JAPAN (TIIS) Ex ia IIC T4

Code number: TC17897

Safety factors: $U_i = 28 \text{ VDC}$, $I_i = 100 \text{ mA}$, $C_i = 1 \text{ nF}$,
 $P_i = 0.7 \text{ W}$, $L_i = 0$, $T_{amb} = 60 \text{ °C}$ (140 °F)

CANADA (CSA)

Class I Division 1 and Division 2, Groups A, B, C, D;

Class II Division 1 and Division 2, Groups G and
 Coal Dust;

Class III CSA File No: 213862 0 000, CSA Report: 1300863

Safety factors: $T_{amb} = 60 \text{ °C}$, T4,

Intrinsically safe when connected as per

Installation Drawing DRW213478.

CHINA (PCEC) Ex ia II CT4

Certificate No. CE092145

Standard GB3836.1-2000 and GB3836.4-2000

IECEX (VTT) Ex ia IIC T4 Ga

IECEX VTT 09.0002x issue No: 1

Safety factors $U_i = 28 \text{ V}$, $I_i = 100 \text{ mA}$, $P_i = 700 \text{ mW}$
 $C_i = 1 \text{ nF}$, L_i negligibly low

Environmental specification

T_{amb} -40 ... +60 °C (-40 ... +140 °F)

P_{amb} 0.8 ... 1.1 bar

Dimensions

Dimensions in mm (inches)

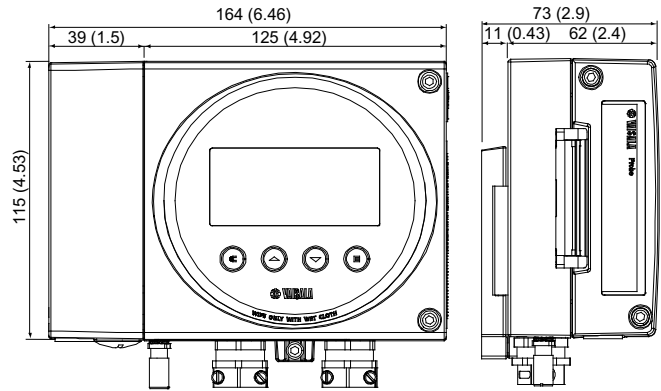

Accessories

Accessories		HMT361	HMT363	HMT364	HMT365	HMT367	HMT368
Accessory	part number						
Ball valve ISO 1/2 with welding joint	BALLVALVE-1						√
Cable Gland M20 x 1.5 with splitting seal	HMP247CG		√		√	√	
Duct installation kit	210697		√			√	
Fitting body ISO1/2 solid structure	DRW212076SP						√
Fitting body M22 x 1.5	17223			√			
Fitting body NPT1/2	17225			√			
Fitting body NPT1/2 solid structure	NPTFITBODASP						√
Mounting flange	210696				√		
Swagelok for 12mm probe, 1/2" NPT thread	SWG12NPT12		√			√	
Swagelok for 12mm probe, 3/8" ISO thread	SWG12ISO38		√			√	

VAISALA

For more information, visit
www.vaisala.com or contact
 us at sales@vaisala.com

Ref. B210956EN-A ©Vaisala 2010
 This material is subject to copyright protection, with all
 copyrights retained by Vaisala and its individual partners. All
 rights reserved. Any logos and/or product names are trademarks
 of Vaisala or its individual partners. The reproduction, transfer,
 distribution or storage of information contained in this brochure
 in any form without the prior written consent of Vaisala is strictly
 prohibited. All specifications — technical included — are subject
 to change without notice.



HMT310 Humidity and Temperature Transmitter



The Vaisala HUMICAP® Humidity and Temperature Transmitter HMT310 models (from left to right): HMT313, HMT317, HMT314, HMT318, HMT315 and HMT311.

Features/Benefits

- Next-generation Vaisala HUMICAP® Sensor for excellent accuracy and stability
- Full 0 ... 100 %RH measurement, temperature range up to +180 °C (depending on model)
- Small size, easy to integrate
- Insensitive to dust and most chemicals
- NIST traceable

Reliable Vaisala HUMICAP® Technology

The HMT310 incorporates the latest-generation Vaisala HUMICAP® Sensor. The Vaisala HUMICAP® Sensor is a capacitive thin-film polymer sensor. It features high accuracy, excellent long-term stability and negligible hysteresis. It is insensitive to dust, particulate dirt and most chemicals.

Several Outputs, One Connector

The HMT310 is powered up with 12 ... 35 VDC. It has two analog outputs and an RS-232 serial output. The output signal and the supply power travel in the same cable, the only cable connected to the unit.

Chemical Purge

Chemical purge helps to maintain measurement accuracy between calibration intervals and it involves heating the sensor to remove harmful chemicals. The function can be initiated manually or programmed to occur at set intervals.

Optional Functions

The following optional functions are available: several probes for various applications, calculated humidity quantities, different mounting kits, sensor protection options and probe cable lengths, warmed probe and sensor heating for high humidity conditions (HMT317), and chemical purge for applications risking an interference with chemicals in the measuring environment.

Technical Data

Measured Values

RELATIVE HUMIDITY

Measurement range 0 ... 100 %RH

Sensor

Vaisala HUMICAP®180R typical applications
 Vaisala HUMICAP®180RC applications with chemical
 purge and/or warmed probe

Accuracy (incl. non-linearity, hysteresis and repeatability)

at a temperature range of

+15 ... +25 °C ±1 %RH (0 ... 90 %RH)
 ±1.7 %RH (90 ... 100 %RH)
 -20 ... +40 °C ±(1.0 + 0.008 x reading) %RH
 -40 ... +180 °C ±(1.5 + 0.015 x reading) %RH

Factory calibration uncertainty ±0.6 %RH (0 ... 40 %RH)*
 (+20 °C) ±1.0 %RH (40 ... 97 %RH)*

* Defined as ±2 standard deviation limits. Small variations possible, see also calibration certificate.

Response time (90 %) at +20 °C 17 s with grid filter
 in 0.1 m/s air flow 50 s with grid and steel, netting filter
 60 s with sintered filter

TEMPERATURE

HMT311 -40 ... +60 °C (-40 ... +140 °F)
 HMT313 -40 ... +80 °C (-40 ... +176 °F)
 or -40 ... +120 °C (-40 ... +248 °F)
 HMT314, HMT315, HMT317, HMT318 -70 ... +180 °C (-94 ... +356 °F)

Accuracy over temperature range (see graph below)

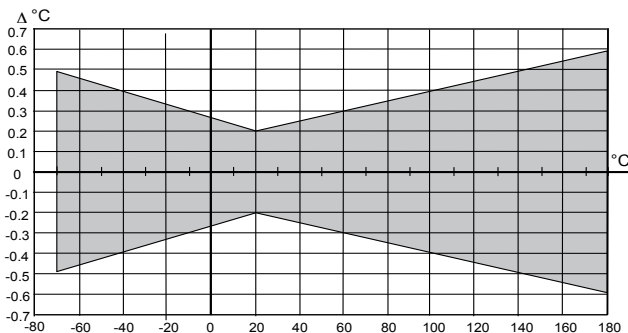

Typical temperature dependence of electronics ±0.05 °C/°C (±0.005 °F/°F)
 Temperature sensor Pt100 IEC751/3 class B

Electrical Connections

Two analog outputs, 0 ... 20 mA or 4 ... 20 mA
 selectable and scalable
 Typical accuracy of analog output at +20 °C ±0.05 % full scale
 Typical temperature dependence 0.005 %/°C (0.003 %/°F)
 of analog output of full scale
 Serial output RS-232C
 Connections M12 8-pole connector with RS-232C,
 current outputs (two channels) and U_{in}
 Operating voltage 12 ... 35 VDC, the maximum
 operating voltage for a device with
 sensor heating is 24 VDC
 Power consumption 30 mA with RS-232
 External load R_i < 500 Ohm
 Startup time after power-up 3 s

General

Operating temperature range for electronics -40 ... +60 °C (-40 ... +140 °F)
 Storage temperature range -55 ... +80 °C (-67 ... +176 °C)
 Operating pressure
 HMT314 0 ... 100 bar
 HMT318 0 ... 40 bar
 HMT315, HMT317 vapor tight
 Transmitter housing material G-AlSi10Mg
 Transmitter base material ABS/PC
 Housing classification IP65
 Cable feed through 8-pole connector with 5 m cable,
 alternatives Female 8-pin connector screw joint for
 cable diameter 4 ... 8 mm
 Sensor protection PPS grid with stainless steel net,
 PPS grid, Sintered filter
 Membrane stainless steel filter
 Complies with EMC standard EN61326-1, Industrial environment

Note: When using the current output, the RF field susceptibility level according to standard EN61000-4-3 with a frequency band of 110 ... 165 MHz, is only 3V/m (generic environment) with the specified accuracy.

HUMICAP® is a registered trademark of Vaisala.



For more information, visit
www.vaisala.com or contact
 us at sales@vaisala.com

Ref. B210769EN-D ©Vaisala 2011
 This material is subject to copyright protection, with all
 copyrights retained by Vaisala and its individual partners. All
 rights reserved. Any logos and/or product names are trademarks
 of Vaisala or its individual partners. The reproduction, transfer,
 distribution or storage of information contained in this brochure
 in any form without the prior written consent of Vaisala is strictly
 prohibited. All specifications — technical included — are subject
 to change without notice.



Vaisala HUMICAP® Humidity and Temperature Transmitters HMT120 and HMT130



The HMT120/130 with and without a display.

The Vaisala HUMICAP® Humidity and Temperature Transmitters HMT120 and HMT130 are designed for humidity and temperature monitoring in cleanrooms and are also suitable for demanding HVAC and light industrial applications.

Performance

The HMT120/130 incorporates Vaisala HUMICAP® technology that measures relative humidity accurately and reliably. The Vaisala HUMICAP® is resistant to dust and most chemicals.

The transmitter enclosure is optimized for use in cleanrooms. The smooth surface of the enclosure makes it easy to clean and the enclosure material is chosen to tolerate purifying agents. Furthermore, the cabling can be done through the back wall of the transmitter.

Interchangeable Probe

The HMT120/130 transmitters use a fully interchangeable relative humidity probe. The probe can be easily removed and replaced with a new one without having to adjust the transmitter, which allows for easy and quick recalibration of the transmitter. The probe can be adjusted using one of Vaisala's portable meters as a reference.

Also available is a constant output probe with fixed RH and T output for convenient inspection of the monitoring system and signal transfer line.

Available Options

The HMT120 and HMT130 transmitters are available as wall mounted or with remote probe. For high temperature applications or

Features/Benefits

- Vaisala HUMICAP® technology with humidity sensor HUMICAP® 180R
- 2-wire loop-powered or 3-wire voltage output configurations
- Interchangeable probe (easy field calibration)
- Accurate and reliable
- Resistant to dust and most chemicals
- Optional LCD display
- USB cable available for a PC connection for maintenance
- Wall-mounted or with a remote probe
- Constant output probe available
- Can be mounted outdoors using a Vaisala installation kit and the Vaisala Radiation Shield DTR504A
- Enclosure IP65
- NIST traceable (certificate included)
- Suitable for cleanrooms and demanding HVAC and light industrial applications

where space is limited, the remote probe is ideal. The transmitters come with an optional LCD display, which shows the measurement results of selected parameters in selected units. The parameters are displayed simultaneously at two separate rows on the display.

Technical Data

Performance

RELATIVE HUMIDITY

Measurement range	0 ... 100 %RH
Accuracy including non-linearity, hysteresis, and repeatability	
temperature range	0 °C ... +40 °C
0 ... 90 %RH	±1.7 %RH
90 ... 100 %RH	±2.5 %RH
temperature range	-40 ... 0 °C, +40 ... +80 °C
0 ... 90 %RH	±3.0 %RH
90 ... 100 %RH	±4.0 %RH
Factory calibration uncertainty at +20 °C (+68 °F)	±1.5 %RH
Humidity sensor	Vaisala HUMICAP® 180R
Stability	±2 %RH over 2 years

TEMPERATURE

Measurement range	-40 °C ... +80 °C
Accuracy over temperature range	
at +15 °C ... +25 °C	±0.2 °C
at 0 ... +15 °C and at +25 °C ... +40 °C	±0.25 °C
at -40 °C ... +0 °C and at +40 °C ... +80 °C	±0.4 °C
Temperature sensor	Pt1000 RTD 1/3 Class B IEC 751
Operating temperature range	
transmitter body, no display	-40 °C ... +60 °C
transmitter body, with display	-20 °C ... +60 °C
HMP110 probe	-40 °C ... +80 °C
Storage temperature range	-50 °C ... +70 °C
Electromagnetic compatibility	EN 61326-1 and EN 55022

Inputs and Outputs

HMT120 TWO-WIRE TRANSMITTER (LOOP POWERED)

Current output signals	4 ... 20 mA
External loop voltage	10 ... 30 VDC ($R_L = 0$ ohms)
	20 ... 30 VDC ($R_L < 500$ ohms)

HMT130 THREE-WIRE TRANSMITTER

Voltage output signals	0 ... 1 V, 0 ... 5 V, 0 ... 10 V or user defined between 0 ... 10 V
Min output resistance	1 kohm
Serial output	RS485, non-isolated
Relay output	1 relay (max. 50 VDC, 200 mA)
Supply voltage	10 ... 35 VDC
	15 ... 35 VDC (when output 0 ... 10 V)
	24 VAC (±20 %)
Current consumption at 24 VDC	8 mA, if relay closed 15 mA
Max. additional error caused by the analog outputs after calibration at +20 °C ambient temperature	±0.1 % of FS output signal
Temperature dependence of the analog outputs	±0.005 % of FS output signal

Mechanics

Material

transmitter housing	PBT plastic
display window	PC plastic
probe body	Stainless steel (AISI 316)
probe grid filter	Chrome coated ABS plastic
Housing classification	IP65
Connections	
inputs and outputs	Screw terminals 0.5 ... 1.5 mm ²
probe interface	4-pin M8 female panel connector
Probe cable lengths	3 m, 5 m, 10 m - up to 50 m
Display (optional)	128 x 64 resolution full graphics B&W display without backlight
Weight (including probe)	270 g

Accessories

Humidity and temperature probe	HMP110*
Humidity and temperature replacement probe	HMP110R*
Constant output probe	HMP110REF*
Humidity sensor	HUMICAP® 180R
Probe mounting flange	226061
Probe mounting clamps, 10 pcs	226067
HMP110 sensor protection	
plastic grid filter	DRW010522SP
plastic grid with membrane filter	DRW010525
stainless steel sintered filter	HM46670SP
Probe cable 3 m	HMT120Z300
Probe cable 5 m	HMT120Z500
Probe cable 10 m	HMT120Z1000
Radiation shield	DTR504A
Rain shield with installation kit	215109
Duct installation kit	215619
HMI41 connection cable	25917ZZ
HM70 connection cable	211339
USB serial interface cable	219685

* See separate order form

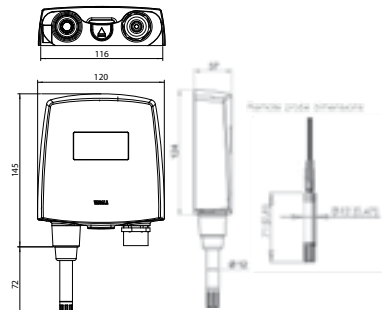

VAISALA

For more information, visit
www.vaisala.com or contact
us at sales@vaisala.com

Ref. B211086EN-B ©Vaisala 2011

This material is subject to copyright protection, with all copyrights retained by Vaisala and its individual partners. All rights reserved. Any logos and/or product names are trademarks of Vaisala or its individual partners. The reproduction, transfer, distribution or storage of information contained in this brochure in any form without the prior written consent of Vaisala is strictly prohibited. All specifications — technical included — are subject to change without notice.



HMW90 Series Humidity and Temperature Transmitters for High Performance HVAC Applications



The HMW90 Series Humidity and Temperature Transmitters are designed for demanding HVAC applications.

The wall-mounted Vaisala HMW90 Series HUMICAP® Humidity and Temperature Transmitters measure relative humidity and temperature in indoor environments, where high accuracy, stability, and reliable operation are required.

The HMW90 series includes models for both current and voltage output. These flexible transmitters offer a variety of options and features. Transmitters include a display and a sliding cover with either a display opening or a solid front. Output options

include both special scalings and calculated dew point and mixing ratio parameters.

Install with Ease and Speed

The HMW90 series transmitters are quick and easy to install. The wiring is connected through the back plate and the electronics with the sensors can then be easily snapped on after wiring is completed.

Dip switches for transmitter configuration can be accessed when the enclosure is open. The most common settings, such as metric/non-metric unit selection and relay set-point, can be easily changed without special tools.

Choose from a Wide Variety of Calibration Options

On-site calibration and adjustment is exceptionally easy. The sliding lid exposes offset trimmers for 1-point calibration of both humidity and temperature parameters. The included display makes adjustment clear and



The sliding cover exposes offset trimmers and service port for calibration.

Features/Benefits

- Easy installation, configuration, and field adjustment
- Vaisala HUMICAP® 180R Sensor with superior long-term stability
- Humidity parameter options: relative humidity, dew point, and mixing ratio
- Full 0 ... 100 %RH measurement range
- Up to ± 1.7 %RH accuracy
- Special output scaling available
- One relay (HMW93 model only)
- UL V0 materials
- User exchangeable humidity and temperature module
- NIST traceable calibration (certificate included)

Typical applications:

- Museums and archive facilities
- Production and warehouse facilities
- Data centers
- Laboratories
- Testing environments

convenient by instantly indicating the effects of changes. A service port enables 2-point calibration, using either a PC or the Vaisala HUMICAP® Hand-Held Humidity and Temperature Meter HM70. The HMW90 series transmitters include a user exchangeable Humidity and Temperature Module HTM10, which can be ordered as a spare part. The module is delivered with a calibration certificate. Calibration and repair services are available through all Vaisala Service Centers.

Technical Data

Models (RH & T)

HMW92	2-wire, current output
HMW92D	2-wire, current output with display
HMW93	3-wire, voltage output
HMW93D	3-wire, voltage output with display

Performance

RELATIVE HUMIDITY	
Measurement range	0 ... 100 %RH
Accuracy	
Temperature range	+10 ... +40 °C (+50 ... +104 °F)
0 ... 90 %RH	±1.7 %RH
90 ... 100 %RH	±2.5 %RH
Temperature range	-5 ... +10 °C, +40 ... +55 °C (+23 ... +50 °F, +104 ... +131 °F)
0 ... 90 %RH	±3 %RH
90 ... 100 %RH	±4 %RH
Stability in typical HVAC applications	±0.5 %RH/year
Humidity sensor	Vaisala HUMICAP® 180R
TEMPERATURE	
Measurement range	-5 ... +55 °C (+23 ... +131 °F)
Accuracy	
+20 ... +30 °C (+68 ... +86 °F)	±0.2 °C (± 0.36 °F)
+10 ... +20 °C, +30 ... +40 °C (+50 ... +68 °F, +86 ... +104 °F)	±0.3 °C (± 0.54 °F)
-5 ... +10 °C, +40 ... +55 °C (+23 ... +50 °F, +104 ... +131 °F)	±0.5 °C (± 0.90 °F)
Temperature sensor	Digital temperature sensor

Operating Environment

Operating temperature range	-5 ... +55 °C (+23 ... +131 °F)
Storage temperature range	-20 ... +60 °C (-4 ... +140 °F)
Electromagnetic compliance	Complies with EMC standard EN61326-1, Industrial Environment

Mechanics

IP class	IP30
Housing color	RAL9003
Housing material	ABS/PC, UL-V0 approved
Output connector	Screw terminals max. wire size 2 mm ² (AWG14)
Service port connector	4-pin M8
Weight	155 g

Inputs and Outputs

HMW92 and HMW92D	
Outputs	2 x 4 ... 20 mA, loop powered
Loop resistance	0 ... 600 Ω
Supply voltage	20 ... 28VDC at 500 Ω load 10 ... 28VDC at 0 Ω load
Isolation between output channels	500VDC
HMW93 and HMW93D	
Outputs	2 x 0 ... 5V, 0 ... 10 V
Load resistance	10 kΩ min.
Supply voltage	18 ... 35 VDC 24 VAC ±20 % 50/60 Hz
Max. current consumption	12 mA max. with relay 25 mA
Relay	1 pcs (max. 50 VDC, 500 mA)
Service port	RS-485 line for temporary service use

Spare Parts and Accessories

Humidity and Temperature Module	HTM10SP
Connection cable for HM70 hand-held meter	219980
USB cable for pc connection	219690

Dimensions

Dimensions in mm.

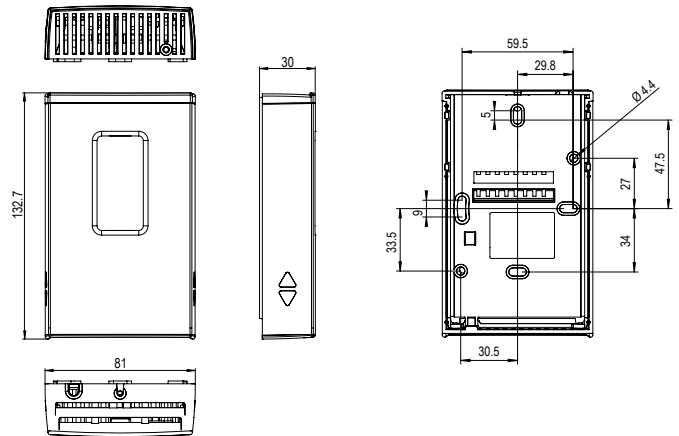

VAISALA

For more information, visit www.vaisala.com or contact us at sales@vaisala.com

Ref. B211183EN-A ©Vaisala 2011
This material is subject to copyright protection, with all copyrights retained by Vaisala and its individual partners. All rights reserved. Any logos and/or product names are trademarks of Vaisala or its individual partners. The reproduction, transfer, distribution or storage of information contained in this brochure in any form without the prior written consent of Vaisala is strictly prohibited. All specifications — technical included — are subject to change without notice.



HMD60/70 Humidity and Temperature Transmitters for Ducts in HVAC Applications



Vaisala HUMICAP® Humidity and Temperature Transmitters HMD60 and HMD70 are designed for use in air conditioning applications where accurate and stable control of relative humidity and temperature are required.

The duct mounted Vaisala HUMICAP® Humidity and Temperature Transmitters HMD60 and HMD70 are designed for monitoring relative humidity and temperature in building energy management systems. The combination of high accuracy, stability and reliable operation, make these products the ideal choice for demanding applications.

Resistant to Chemicals and Dust

The duct mount HMD60 and HMD70 transmitters can also be used in many industrial humidity monitoring applications, where their stability and resistance to chemicals and dust are of great value. A useful feature of these duct mount transmitters is the ability to remove the electronics without removing the unit from the duct.

Measures both Humidity and Temperature

The HMD60 and HMD70 transmitters are available in three models: U for humidity measurement-only, Y for humidity and temperature measurement, and T for temperature only.

Fast, On-Site Calibration

The accuracy of the transmitters is simple to check using either the Vaisala HUMICAP® Hand-Held Humidity and Temperature Meter HM70 or the Vaisala HUMICAP® Humidity Indicator HMI41. The calibration can be done in seconds with a single potentiometer without disturbing the operation, resulting in great savings both in maintenance time and costs.

Features/Benefits

- Full 0 ... 100 %RH measurement
- Accuracy up to ± 2 %RH
- True two-wire transmitters with 4 ... 20 mA loop powered output (HMD60)
- Selectable signal output of 0 ... 1 V, 0 ... 5 V or 0 ... 10 V (HMD70) with optional current module also 0 ... 20 mA (HMD70)
- Vaisala HUMICAP® Sensor for excellent accuracy and long-term stability, negligible hysteresis and resistance to dust and most chemicals.
- Temperature compensated
- IP65 (NEMA 4) housing
- Also available as temperature-only transmitters HMD 60T/70T
- NIST traceable (certificate included)

Technical Data

60 Series: 2-wire, 4 to 20 mA Output

Duct mount	RH only	HMD60U
	RH & T	HMD60Y
	T only	HMD60T

70 Series: 3-wire, Variable Voltage Output

Duct mount	RH only	HMD70U
	RH & T	HMD70Y
	T only	HMD70T

Relative Humidity

Measurement range
duct mount 0 ... 100 %RH*

Accuracy at +20 °C

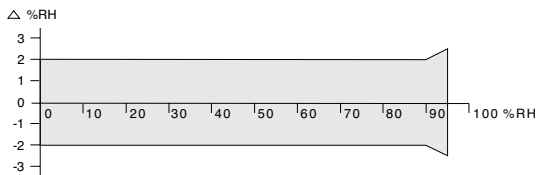

Temperature dependence

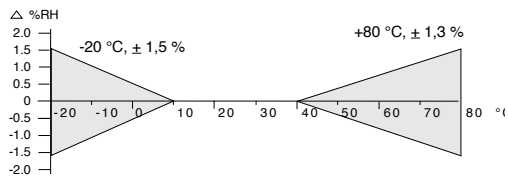

Response time at +20 °C (+68 °F),
90% response 15 s (with membrane filter)

Stability ± 2 %RH / 2 years

Sensor HUMICAP® 180

Temperature (Y and T Models)

Linearity better than 0.1 °C

Sensor Pt 1000 IEC 751 class B

Measurement range -20 ... +80 °C (-4 ... 176 °F) **

Accuracy

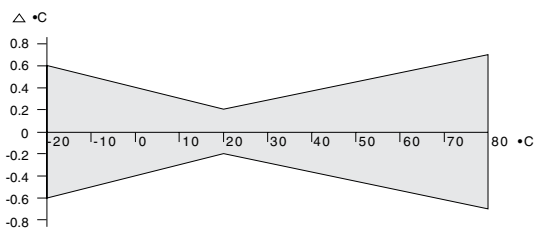

** Optional temperature scales are available on request.

General - 60 Series

Supply voltage	10 ... 35 VDC (RL = 0 ohm)
	20 ... 35 VDC (RL = 500 ohm)
Output signal	4 ... 20 mA

General - 70 Series

Supply voltage range depends on the selected output signal		
	DC	AC
0 ... 1V	10 ... 35 V	9 ... 24 V
0 ... 5V	14 ... 35 V	12 ... 24 V
0 ... 10V	19 ... 35 V	16 ... 24 V
WITH OPTIONAL CURRENT MODULE		
0 ... 20 mA (RL = 0 ohm)	10 ... 35 V	11 ... 24 V
**0 ... 20 mA (RL = 500 ohm)	20 ... 35 V	17 ... 24 V
Power consumption @ 24 VAC		
HMD70U		10 mA typical
HMD70Y		12 mA typical

General

Operating temperature range	
electronics	-5 ... +55 °C (+23 ... +131 °F)
probe	-20 ... +80 °C (-4 ... +176 °F)
Storage temperature range -40 ... +80 °C (-40 ... +176 °F)	
Maximum flow speed	50 m/s
Current module	part no. 18945 HM
Housing	
probe	stainless steel
electronics	cast aluminum
Connections	screw terminals 0.5 ... 1.5 mm ²
Sensor protection	
standard	membrane filter (part no. DRW010525)
optional	stainless steel sintered filter (part no. HM46670SP)
Cable thread-through	
bushing for 7 ... 10 mm (PG9)	
cable housing IP65 (NEMA 4)	part no. 18941HM
armoured cable glands	part no. 10528HM
(must be ordered separately)	

Complies with EMC standard EN61326 and EN55022

VAISALA

For more information, visit
www.vaisala.com or contact
us at sales@vaisala.com

Ref. B210839EN-A ©Vaisala 2009
This material is subject to copyright protection, with all
copyrights retained by Vaisala and its individual partners. All
rights reserved. Any logos and/or product names are trademarks
of Vaisala or its individual partners. The reproduction, transfer,
distribution or storage of information contained in this brochure
in any form without the prior written consent of Vaisala is strictly
prohibited. All specifications — technical included — are subject
to change without notice.



Vaisala INTERCAP® Humidity and Temperature Transmitter Series HMW80



The HMW80 combines excellent stability with easy installation and reliable operation.

Features/Benefits

- Cost-efficient, dependable solution for humidity and temperature measurement for heating and ventilation
- Measurement range 0 ... 100 %RH and -5 ... +55 °C
- Stable and dependable
- Combines excellent stability with easy installation and reliable operation
- Fits EU/US/JPN junction boxes
- 2-year warranty
- No recalibration required
- UL-V0 approved materials used

The two- and three-wire Vaisala INTERCAP® Humidity and Temperature Transmitter Series HMW80 is designed for use in energy management systems in buildings. They combine excellent stability with reliable operation. The HMW80 is easy to install: wire it to the terminal block at the transmitter bottom and close the housing with a snap-on lid to cover the electronics.

Low Maintenance Costs

The HMW80 humidity transmitters use the Vaisala INTERCAP® Sensor – an interchangeable capacitive humidity sensor. The transmitters require no recalibration if the sensor is changed. This means great savings in overall maintenance costs. The sensor is also insensitive to dust as well as to most chemicals.

Measures Both Humidity and Temperature

The HMW80 transmitters are available in four models: HMW82 and HMW83 transmitters measure both humidity and temperature. They measure humidity with a ± 3 %RH accuracy and with a stability of ± 3 %RH over 5 years. The accuracy of the temperature measurement is ± 0.5 °C. Two other models, TMW82 and TMW83, measure temperature only.

Both 2- and 3-wire transmitters are also available: HMW82 and TMW82 are 2-wire (4 ... 20 mA loop powered) transmitters, and HMW83 and TMW83 are 3-wire (0 ... 10 V) transmitters.

Technical Data

Performance

RELATIVE HUMIDITY

Measurement range 0 ... 100 %RH

Accuracy

Temperature range 10 ... 30 °C

30 ... 70 %RH ±3 %RH

0 ... 30 %RH, 70 ... 100 %RH ±5 %RH

Temperature range -5 ... +10 °C, +30 ... +55 °C

0 ... 100 %RH ±7 %RH

Stability

±3 %RH / 5 years

Humidity sensor

Vaisala Intercap®

TEMPERATURE

Measurement range -5 ... +55 °C

Accuracy

+10 ... +30 °C ±0.5 °C

-5 ... +10 °C, +30 ... +55 °C ±1.0 °C

Temperature sensor Digital temperature sensor

Operating environment

Operating temperature range -5 ... +55 °C

Storage temperature range -40 ... +60 °C

Electromagnetic compliance complies with EMC standard EN61326-1, Light industrial Environment

Inputs and outputs

HMW82, TMW82

Outputs 4 ... 20mA, loop powered

Loop resistance 0 ... 500 Ohm

Supply voltage 10 ... 28 VDC

HMW83, TMW83

Outputs 0 ... 10V

Load resistance 10 kohm min

Supply voltage 15 ... 35 VDC / 24 VAC ±20 %

Mechanics

IP class IP30

Housing colour RAL9003

Housing material ABS/PC

UL-V0 approved

Dimensions

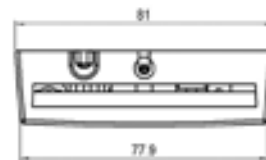
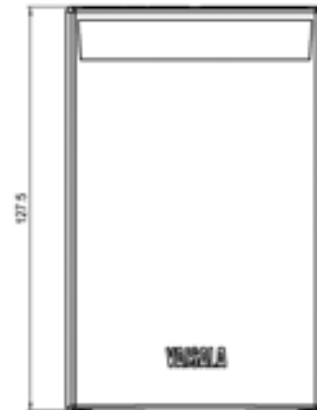
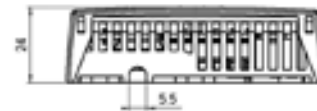

For more information, visit www.vaisala.com or contact us at sales@vaisala.com

Ref. B211060EN-B ©Vaisala 2011

This material is subject to copyright protection, with all copyrights retained by Vaisala and its individual partners. All rights reserved. Any logos and/or product names are trademarks of Vaisala or its individual partners. The reproduction, transfer, distribution or storage of information contained in this brochure in any form without the prior written consent of Vaisala is strictly prohibited. All specifications — technical included — are subject to change without notice.



HMD42/53 Humidity and Temperature Transmitters for Ducts in Commercial HVAC Applications



Features/Benefits

- Designed for building automation applications
- ± 3 %RH accuracy
- Full 0 ... 100 %RH measurement range
- $-20 \dots +60$ °C ($-4 \dots +140$ °F) operating range
- IP65 (NEMA 4) metal housing
- Excellent stability and high reliability
- Fully interchangeable Vaisala INTERCAP® Sensor
- Variety of analog signal outputs available

The duct mounted Vaisala INTERCAP® Humidity and Temperature Transmitters HMD42 and HMD53 are designed for building automation applications. They combine reliable operation with excellent stability, providing low cost of ownership to the user.

Flexibility in Humidity and Temperature Measurement

The HMD42/53 transmitters measure humidity with a ± 3 %RH accuracy and temperature with a ± 0.4 °C (± 0.72 °F) accuracy. They feature various selectable analog output signals and they can be powered by either AC or DC voltage.

Easy Maintenance

The HMD42/53 humidity transmitters use Vaisala INTERCAP® Sensor - the interchangeable capacitive humidity sensor. The transmitters require no recalibration if the sensor is changed. This means great savings in overall maintenance costs.

Reliable Performance in Harsh Environments

The duct mount HMD42/53 transmitters can be installed in various measurement environments due to the robust IP65 (NEMA4) rated metal enclosure, which protects the sensor from dust and splashes of water. The wide measurement temperature range from -20 °C to $+60$ °C ($-4 \dots +140$ °F) covers most HVAC applications.

Typical Applications

- Office buildings
- Retail spaces
- Governmental buildings
- Educational facilities
- Sport and event complexes
- Hotels and conference centers
- Airports
- Metro stations

Technical Data

Relative Humidity

Measurement range	0 ... 100 %RH	
Typical accuracy		
Temperature range	0 ... +40 °C (+32 ... +104 °F)	
0 ... 90 %RH	±3 %RH	
90 ... 100 %RH	±5 %RH	
Temperature range	-20 ... 0 °C, +40 ... +60 °C (-4 ... +32 °F, +104 ... +140 °F)	
0 ... 90 %RH	±5 %RH	
90 ... 100 %RH	±7 %RH	
Humidity sensor	Vaisala INTERCAP®	
Stability	±2 %RH / 2 years	
Response time at 20 °C (+68 °F), 90 % response	15 s	

Temperature

Measurement range	-20 ... +60 °C (-4 ... +140 °F)	
Output scale	-40 ... +60 °C (-40 ... +140 °F)	
Accuracy		
0 ... +40 °C (+32 ... +104 °F)	±0.4 °C (±0.72 °F)	
-20 ... 0 °C, +40 ... +60 °C (-4 ... +32 °F, +104 ... +140 °F)	±0.6 °C (±1.1 °F)	
Sensor	Pt1000 IEC 751 Class B	

General - HMD42

Supply voltage	10 ... 35 VDC ($R_L = 0$ ohm)
	20 ... 35 VDC ($R_L = 500$ ohm)
Output signal	4 ... 20mA

General - HMD53

Supply voltage range depends on the selected output signal		
	DC	AC
0 ... 1V	10 ... 35V	9 ... 24V
0 ... 5V	14 ... 35V	12 ... 24V
0 ... 10V	19 ... 35V	16 ... 24V
WITH OPTIONAL CURRENT MODULE		
0 ... 20 mA ($R_L = 0$ ohm)	10 ... 35V	11 ... 24V
**0 ... 20 mA ($R_L = 500$ ohm)	20 ... 35V	17 ... 24V
Power consumption @ 24VAC	12mA typical	

**Optional temperature scales are available on request.

General

Operating temperature range		
electronics	-5 ... +55 °C (+23 ... +131 °F)	
probe	-20 ... +60 °C (-4 ... +140 °F)	
Storage temperature range	-40 ... +60 °C (-40 ... +140 °F)	
Maximum flow speed	50 m/s	
Housing material		
probe	stainless steel	
electronics	cast aluminium	
Housing classification	IP65 (NEMA 4)	
Connections	screw terminal 0.5 ... 1.5 mm ²	
Cable thread-through bushing for 7 ... 10 mm (PG9) included	(18941HM)	
Complies with EMC standard EN61326 and EN55022		

Accessories

Armoured cable gland	10528HM
Current module (for HMD53)	18945HM

Spare Parts

Vaisala INTERCAP sensor, 1 piece	15778HM
Vaisala INTERCAP sensor, 10 pcs	INTERCAPSET-10PCS
Membrane filter	DRW010525
Sintered filter	HM46670SP

Dimensions

Dimensions in mm

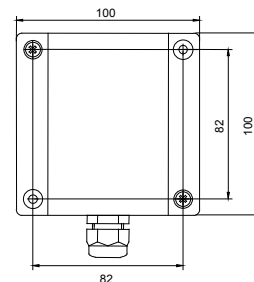
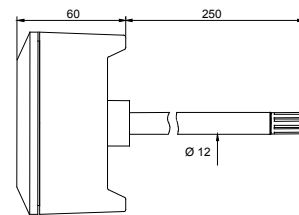

VAISALA

For more information, visit
www.vaisala.com or contact
us at sales@vaisala.com

Ref. B211140EN-A ©Vaisala 2011

This material is subject to copyright protection, with all copyrights retained by Vaisala and its individual partners. All rights reserved. Any logos and/or product names are trademarks of Vaisala or its individual partners. The reproduction, transfer, distribution or storage of information contained in this brochure in any form without the prior written consent of Vaisala is strictly prohibited. All specifications — technical included — are subject to change without notice.



HMM210 Series Humidity Modules for Environmental Chambers

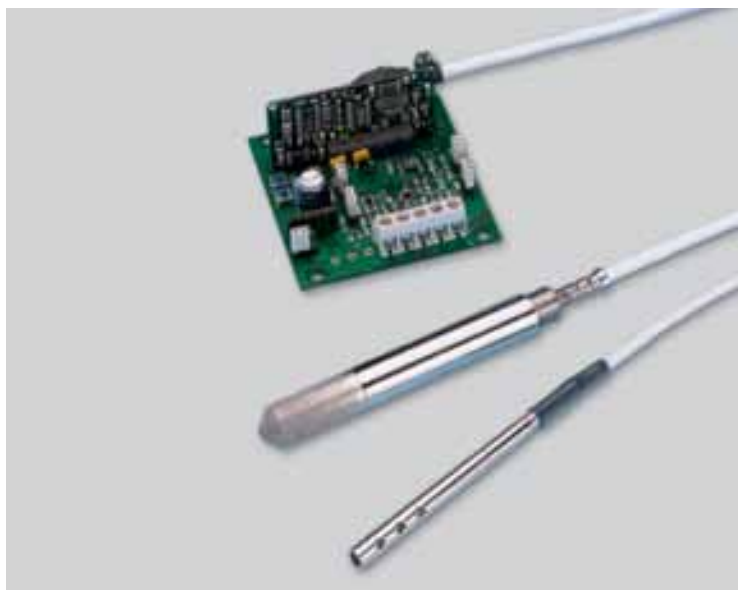

Vaisala HUMICAP® Humidity and Temperature Module Series HMM210 provide fast real-time measurement in a wide temperature range. The modules are especially suitable for demanding OEM applications, e.g. environmental chambers and incubators.

Features/Benefits

- Three probe configurations:
- Relative humidity (RH) plus temperature (T) probe.
- Dewpoint probe with probe heating. By heating the whole probe a few degrees above ambient condensation is avoided.
- Dewpoint probe described above, together with a temperature probe for obtaining relative humidity and temperature outputs.
- Three module configurations
- Different probe and cable lengths
- Chemical purge option maintains high measurement performance in demanding chemical conditions.
- Calibration certificate included

The Vaisala HUMICAP® Humidity and Temperature Module Series HMM210 are designed for OEM type applications needing humidity or dewpoint measurement in demanding environments, e.g. in environmental chambers, growth chambers and incubators.

Demanding Applications

The HMM210 modules are optimized for harsh environments with both high humidities and a wide temperature range. The humidity measurement is fully temperature compensated. In addition, the modules remain accurate and reliable under extreme conditions where a combination of high humidity and rapidly changing temperature can result in condensation on the sensor head.

The modules are highly versatile and flexible. They provide either

relative humidity and temperature or dewpoint measurement with various configurations. All modules have microprocessor based electronics and are equipped with analog or digital outputs.

Unique Warmed Probe

The warmed probe and composite sensor, available on the dewpoint probe configuration, is warmed to always remain a few degrees higher than ambient. Advantages of this patented technique include:

- No condensation problems on the probe, as the temperature of the probe always remains higher than the ambient.
- Fast response time, especially in rapidly changing temperatures.
- Improved stability and accuracy in high humidities.

Vaisala HUMICAP® Sensor and Chemical Purge Option

The HMM210 modules use Vaisala HUMICAP®180R sensors for best possible stability. The sensor is insensitive to dust and to most chemicals. In conditions of extraordinary high levels of chemicals and cleaning agents, chemical purge is available as an option. With chemical purge, contaminants are evaporated from the sensor and performance is returned to normal.

Technical Data

Relative Humidity

Measurement range	0 ... 100 %RH
Accuracy (including non-linearity, hysteresis and repeatability)	± 2 %RH (0 ... 90 %RH) ± 3 %RH (90 ... 100 %RH)
Response time (90 % at +20 °C/+68 °F) in still air (with sintered filter)	60 s
Typical temperature dependence of electronics	0.02 %RH/°C (0.02 %RH/°F)
Humidity sensor	HUMICAP®180R

Temperature

Measurement range	-70 ... +180 °C (-94 ... +356 °F)
Typical accuracy of electronics at +20 °C	± 0.1 °C (± 0.18 °F)
Typical temperature dependence of electronics	0.0025 °C/°C (0.0025 °F/°F)
Temperature sensor in RH+T probe:	
HMM211 and HMM213	Pt 100 RTD IEC 751 1/3 Class B
HMM212	Pt 1000 RTD IEC 751 1/3 Class B
Additional temperature probe	Pt 100 RTD IEC 751 1/4 Class B

Outputs

Two analog outputs selectable	
HMM211	0 ... 1 V, 0 ... 5 V, 0 ... 10 V 0 ... 20 mA
HMM212	4 ... 20mA (loop powered)
Digital output	
HMM213	RS232

Dimensions

Dimensions in mm (inches)

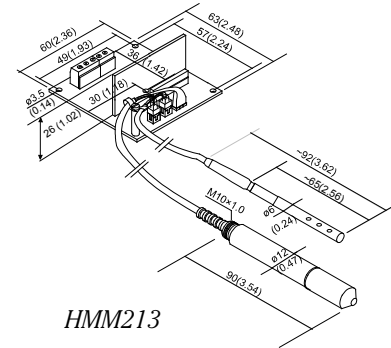
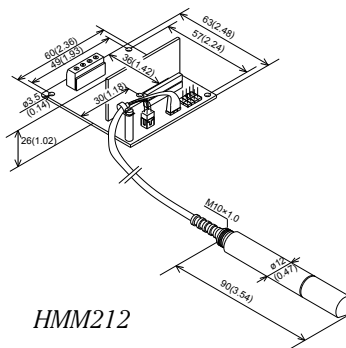
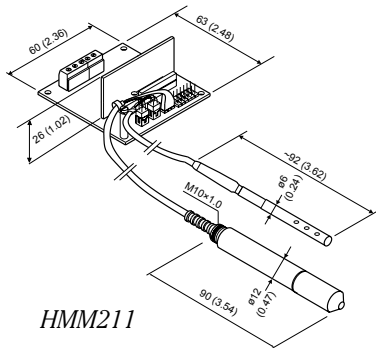

General

Operating temperature range	
Probe	-70 ... +180 °C (-94 ... +356 °F)
Electronics	-5 ... +55 °C (+23 ... +131 °F)
Storage temperature range (Electronics)	-40 ... +70 °C (-40 ... +158 °F)
Sensor protection (standard)	stainless steel sintered filter
Connections	screw terminals for 0.5 ... 1.5 mm ² wires

Power Supply

Operating voltage	10 ... 35 VDC
In modules with analog outputs the supply range depends to a certain extent on the selected output range.	
Current consumption without sensor head warming or re-gaining option	
HMM211 & HMM213	12 mA at 35 VDC

Configuration Options

	Compatible with modules:		
PROBES	HMM211	HMM212	HMM213
RH+T	yes	yes	yes
Dewpoint (heated composite sensor)	yes		yes
Temperature	yes		yes
CABLE LENGTHS			
RH+T and Dewpoint probes			65, 150 and 300 cm
Temperature probe			150 and 300 cm
CHEMICAL PURGE	Automatically takes place at power-up		
HUMICAP® is a registered trademark of Vaisala.			



For more information, visit www.vaisala.com or contact us at sales@vaisala.com

Ref. B210901EN-B ©Vaisala 2011
This material is subject to copyright protection, with all copyrights retained by Vaisala and its individual partners. All rights reserved. Any logos and/or product names are trademarks of Vaisala or its individual partners. The reproduction, transfer, distribution or storage of information contained in this brochure in any form without the prior written consent of Vaisala is strictly prohibited. All specifications — technical included — are subject to change without notice.



HMM100 Humidity Module for Environmental Chambers



The Vaisala HUMICAP® Humidity Module HMM100.

Features/Benefits

- Full temperature compensation over the operating temperature range of -70 °C ... +180 °C
- High temperature tolerance, also suitable for heat-sterilization
- Excellent measurement accuracy with Vaisala HUMICAP® 180R sensor
- Durable
- Easy field calibration by trimmers
- Maintenance-free
- Easy to install
- Applications: test chambers, incubators

The HMM100

The Vaisala HUMICAP® Humidity Module HMM100 is an open frame module for integration into environmental chambers. The modules provide a single analog output channel for relative humidity (RH) or dewpoint (T_d).

Two probes are available, one made of plastics, the other of stainless steel. Several cable lengths up to 3 meters are available. Both the probes have the Vaisala HUMICAP® 180R sensor which ensures excellent measurement accuracy.

Robust and Reliable

The HMM100 probe works in freezing conditions (-70 °C) and also in temperatures up to +180 °C. The

HMM100 is easy to install and the probe can be freely placed in a test chamber as the speed of airflow does not affect the measurement.

Maintenance-free

Compared to psychrometers, the HMM100 is practically maintenance-free. There is no wick that needs changing and there is no need for a water tank or water pump. Thus, environmental stress screening can be done reliably.

Accessories

The accessories available are a component board mounting bracket with a lid, probe clamp, USB-cable for service use, a module housing and a probe mounting flange.

Technical Data

Performance

RELATIVE HUMIDITY	
Measurement range	0 ... 100 %RH
Accuracy (incl. non-linearity, hysteresis and repeatability)	
temperature range	-20 ... +40 °C
0 ... 90 %RH	±2 %RH
90 ... 100 %RH	±3 %RH
temperature range	-40 ... -20 °C, +40 ... +180 °C
0 ... 90 %RH	±2.5 %RH
90 ... 100 %RH	±3.5 %RH
Factory calibration uncertainty (+20 °C)	±1.5 %RH
Humidity sensor	Vaisala HUMICAP® 180R
DEW POINT TEMPERATURE	
Measurement range	-20 ... +100 °C (-4 ... +212 °F) _{T_d}
Accuracy (incl. non-linearity, hysteresis and repeatability when dew point depression <20 °C (Ambient temperature - dew point))	±2 °C T _d

Operating Environment

Operating temperature range	
component board	-5 ... +55 °C (+23 ... +131 °F)
stainless steel and plastic probe	-70 ... +180 °C (-94 ... +356 °F)
porous PTFE filter stainless steel, sintered filter	-70 ... +180 °C (-94 ... +356 °F)
plastic grid, membrane filter	-20 ... +80 °C (-4 ... +176 °F)
Electromagnetic compatibility	Complies with EMC standard EN61326-1, for use in light industrial environments

Input and Outputs

Operating voltage	
2-wire model	24 VDC
3-wire model	10 ... 35 VDC or 24 VAC
	15 ... 35 VDC or 24 VAC when 0 ... 10 V output is used
Power consumption	6 mA
Analog output types (1 output selectable)	
2-wire model	4 ... 20 mA (loop-powered)
3-wire model	0 ... 20 mA, 0 ... 1 V/5 V/10 V
Max. wire size	0.5 ... 1.5 mm ² (AWG)
Service port	M8 connector for USB cable

Mechanics

Service cable connector	M8 series 4-pin (male)
Probe diameter	12 mm
Probe cable lengths	0.6/1.55/2.9 m
Probe material	
plastics	PPS
stainless steel	AISI316/PPS
Probe mounting clamp	AISI316
Mounting bracket material	
lid	ABS/PC
bottom plate	Al
Module housing material	ABS/PC (cover)

Options and Accessories

Humidity sensor	HUMICAP180R
Membrane filter	10159HM
Plastic grid filter	6221
Porous PTFE filter	219452SP
Stainless steel sintered filter	HM47280SP
Mounting bracket with lid	225979
Module housing (IP65)	226060
Probe mounting flange	226061
Probe mounting clamp set (10 pcs)	226067
USB cable	226068

Dimensions

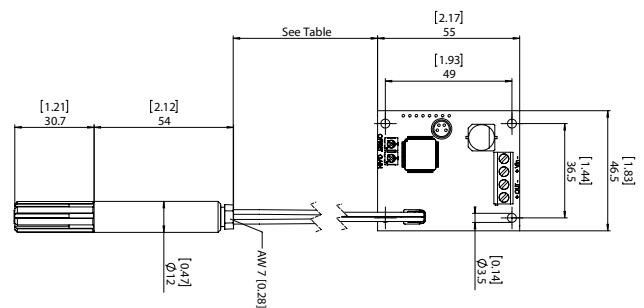

VAISALA

For more information, visit www.vaisala.com or contact us at sales@vaisala.com

Ref. B210813EN-A ©Vaisala 2010
 This material is subject to copyright protection, with all copyrights retained by Vaisala and its individual partners. All rights reserved. Any logos and/or product names are trademarks of Vaisala or its individual partners. The reproduction, transfer, distribution or storage of information contained in this brochure in any form without the prior written consent of Vaisala is strictly prohibited. All specifications — technical included — are subject to change without notice.



Vaisala INTERCAP® Humidity and Temperature Probe HMP60



The HMP60 for extreme conditions.

Features/Benefits

- Miniature-size humidity probe
- Low power consumption
- Measurement range:
0 ... 100 %RH; -40 ... +60°C
- Cable detachable with
standard M8 connector
- Rugged metal housing
- Interchangeable Vaisala
INTERCAP® Sensor
- Optional RS485 digital output
Optional dew point output
- Applications: volume
applications, integration
into other manufacturers'
equipment, glove boxes,
greenhouses, fermentation
chambers, data loggers

HMP60

The HMP60 is a simple, durable and cost-effective humidity probe. It is suitable for volume applications, integration into other manufacturers' equipment, incubators, glove boxes, greenhouses, fermentation chambers, and data loggers.

Easy Installation

The probe cable has a screw-on quick connector for easy installation. Different cable lengths are available. Also other compatible M8 series cables can be used. Accessories are available for different installation needs.

Low Current Consumption

The HMP60 is suitable for battery-powered applications because of its very low current consumption.

Several Outputs

There are two configurable voltage outputs with relative humidity, temperature or dew point scaling. Four voltage output ranges are available.

Rugged Design

The HMP60 is designed for extreme conditions. The stainless steel body of the HMP60 is classified as IP65. The probe has a sealed structure and the sensor is protected by a membrane filter and a plastic grid, or optionally by a stainless steel filter.

Recalibration Not Needed

The Vaisala INTERCAP® Sensor is interchangeable. No recalibration is required; the sensor can simply be replaced, also in the field.

Technical Data

Performance

RELATIVE HUMIDITY	
Measurement range	0 ... 100 %RH
Typical accuracy	
temperature range	0 ... +40 °C
0 ... 90 %RH	±3 %RH
90 ... 100 %RH	±5 %RH
temperature range	-40 ... 0 °C, +40 ... +60 °C
0 ... 90 %RH	±5 %RH
90 ... 100 %RH	±7 %RH
Humidity sensor	Vaisala INTERCAP®
TEMPERATURE	
Measurement range	-40 ... +60 °C
Accuracy over temperature range -40 ... +60 °C	±0.6 °C
DEW POINT	
Measurement range	-40 ... +60 °C
Typical accuracy	
temperature range	0 ... +40 °C
when dew point depression < 15 °C	±2 °C
temperature range	-40 ... 0 °C, +40 ... +60 °C
when dew point depression < 10 °C	±3 °C
dew point depression = ambient temperature - dew point	

Inputs and Outputs

Operating voltage	5 ... 28 VDC / 8 ... 28 VDC with
(Use lowest available operating voltage to minimize heating.)	5 V output
	8 ... 28VDC with loop power converter
Current consumption	1 mA average, max. peak 5 mA
Start-up time	
probes with analog output	4 s at operating voltage
	13.5 ... 16.5 VDC
	2 s at other valid operating voltages
probes with digital output	1 s
Outputs	
2 channels	0 ... 1 VDC / 0 ... 2.5 VDC / 0 ... 5 VDC / 1 ... 5 VDC
1-channel loop-power converter (separate module, compatible with humidity accuracy only)	4 ... 20 mA
digital output (optional)	RS485 2-wire half duplex
External loads	
0 ... 1 V	R _L min 10 kΩ
0 ... 2.5 V / 0 ... 5 V	R _L min 50 kΩ

Operating Environment

Operating temperature	-40 ... +60 °C
Electromagnetic compatibility	EN 61326-1: Electrical equipment for measurement, control and laboratory use – EMC requirements – for use in industrial locations.

Mechanics

Materials	
body	stainless steel (AISI 316)
grid filter	chrome coated ABS plastic
cable	polyurethane or FEP
Housing classification	IP65
Body thread	M12x1 / 10 mm
Cable connector	4-pin M8 (IEC 60947-5-2)
Weight	
probe	17 g
probe with 0.3 m cable	28 g

Options and Accessories

Vaisala INTERCAP® Sensor, 1 piece	15778HM
Vaisala INTERCAP® Sensor, 10 pcs	INTERCAPSET-10PCS
Sensor protection	
plastic grid	DRW010522
membrane filter	DRW010525
stainless steel sintered filter	HM46670SP
4 ... 20mA loop power converter	UI-CONVERTER-1
Mounting bracket for converter	225979
Plastic M12 installation nuts, pair	18350SP
USB cable for PC connection	219690
Probe mounting clamp set, 10 pcs	226067
Probe mounting flange	226061
Connection cables	
0.3 m PU	HMP50Z30SP
3 m PU	HMP50Z300SP
180 °C 3 m FEP	226902SP

Dimensions

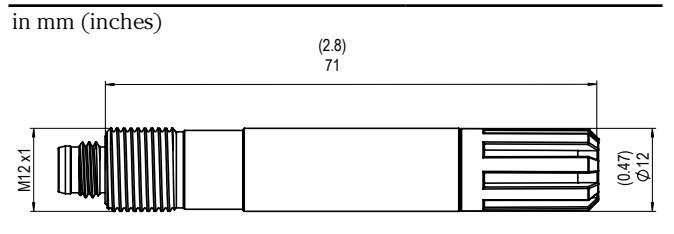

For more information, visit www.vaisala.com or contact us at sales@vaisala.com

Ref. B210851EN-B ©Vaisala 2011
 This material is subject to copyright protection, with all copyrights retained by Vaisala and its individual partners. All rights reserved. Any logos and/or product names are trademarks of Vaisala or its individual partners. The reproduction, transfer, distribution or storage of information contained in this brochure in any form without the prior written consent of Vaisala is strictly prohibited. All specifications — technical included — are subject to change without notice.



Vaisala HUMICAP® Humidity and Temperature Probe HMP110



The HMP110 with excellent stability and high chemical tolerance.

Features/Benefits

- Miniature-size humidity transmitter
- Low power consumption and fast startup for battery powered applications
- Measurement range: 0 ... 100 %RH; -40 ... +80°C
- Cable detachable with standard M8 quick connector
- Reliable: Latest generation HUMICAP® 180R sensor for best stability and high chemical tolerance. IP65 metal housing.
- Optional RS485 digital output
- Traceable: Comes with calibration certificate. $\pm 1.7\%$ RH measurement accuracy (0 ... 90%RH)
- HMP110R replacement probe service available for easy maintenance
- Optional dew point calculation

HMP110

The HMP110 is a trouble-free and cost-effective humidity transmitter with high accuracy and good stability. It is suitable for volume applications or integration into other manufacturers' equipment. The HMP110 is also suitable for glove boxes, greenhouses, fermentation and stability chambers, data loggers, and incubators.

Easy Installation

The probe cable has a screw-on quick connector for easy installation. Different cable lengths and accessories are available.

Low Current Consumption

HMP110 is suitable for battery-powered applications because of its very low current consumption. It also has a fast start-up time.

Several Outputs

The temperature measurement is a standard feature, dew point measurement is optional. Three standard voltage outputs are available.

Robust Design

The stainless steel body of the HMP110 is classified as IP65. Thus, it survives rough conditions. The HMP110 has high chemical tolerance because of the HUMICAP® 180R sensor.

Easy Maintenance

Maintaining measurement traceability is easy using the HMP110R replacement probe. We send you a replacement probe, you detach the old probe and send it back to us. In this way the measurement is available at all times without interruptions.

Technical Data

Performance

RELATIVE HUMIDITY	
Measurement range	0 ... 100 %RH
Accuracy (incl. non-linearity, hysteresis and repeatability)	
temperature range	0 ... +40 °C
0 ... 90 %RH	±1.7 %RH
90 ... 100 %RH	±2.5 %RH
temperature range	-40 ... 0 °C, +40 ... +80 °C
0 ... 90 %RH	±3.0 %RH
90 ... 100 %RH	±4.0 %RH
Factory calibration uncertainty (+20 °C)	± 1.5 %RH
Humidity sensor	Vaisala HUMICAP® 180R
Stability	±2 %RH over 2 years
TEMPERATURE	
Measurement range	-40 ... +80 °C
Accuracy over temperature range	
0 ... +40 °C,	±0.2 °C
-40 ... 0 °C, +40 ... +80 °C	±0.4 °C
Temperature sensor	Pt1000 RTD 1/3, Class B IEC 751
DEW POINT	
Measurement range	-40 ... +80 °C
Accuracy (incl. non-linearity, hysteresis and repeatability)	
temperature range	0 ... +40 °C
when dew point depression < 15 °C	±1 °C
when dew point depression 15 ... 25 °C	±2 °C
temperature range	-40 ... 0 °C, +40 ... +80 °C
when dew point depression < 15 °C - dew point depression = ambient temperature - dew point	±2 °C

Inputs and Outputs

Operating voltage	5 ... 28 VDC / 8 ... 28 VDC with
(Use lowest available operating voltage to minimize heating)	5 V output
	8 ... 28 VDC with loop power converter
Current consumption	1 mA average, max. peak 5 mA
Start-up time	
probes with analog output	4 s at operating voltage
	13.5 ... 16.5 VDC
	2 s at other valid operating voltages
probes with digital output	1 s
Outputs	
2 channels	0 ... 1 VDC / 0 ... 2.5 VDC / 0 ... 5 VDC / 1 ... 5 VDC
1-channel loop-power converter (separate module, compatible with humidity accuracy only)	4 ... 20 mA
digital output (optional)	RS485 2-wire half duplex

External loads	
0 ... 1 V	R_L min 10 k Ω
0 ... 2.5 V / 0 ... 5 V	R_L min 50 k Ω

Operating Environment

Operating temperature range	-40 ... +80 °C
Electromagnetic compatibility	EN 61326-1: Electrical equipment for measurement, control and laboratory use – EMC requirements – for use in industrial locations.

Mechanics

Materials	
body	stainless steel (AISI 316)
grid filter	chrome coated ABS plastic
cable	polyurethane or FEP
Housing classification	IP65
Body thread	M12x1 / 10 mm
Cable connector	4-pin M8 (IEC 60947-5-2)
Weight	
probe	17 g
probe with 0.3 m cable	28 g

Options and Accessories

Sensor protection	
plastic grid	DRW010522
membrane filter	DRW010525
stainless steel sintered filter	HM46670SP
4 ... 20 mA loop power converter	UI-CONVERTER-1
Mounting bracket for converter	225979
Plastic M12 installation nuts, pair	18350SP
USB cable for PC connection	219690
Probe mounting clamp set, 10 pcs	226067
Probe mounting flange	226061
Connection cables	
standard 0.3 m	HMP50Z032SP
standard 3 m	HMP50Z300SP
80 °C 1.5 m	225777SP
80 °C 3 m	225229SP
180 °C 3 m FEP	226902SP

Dimensions

Dimensions in mm (inches)

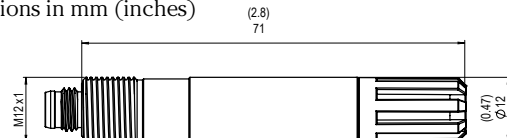

VAISALA

For more information, visit www.vaisala.com or contact us at sales@vaisala.com

Ref. B210852EN-B ©Vaisala 2011

This material is subject to copyright protection, with all copyrights retained by Vaisala and its individual partners. All rights reserved. Any logos and/or product names are trademarks of Vaisala or its individual partners. The reproduction, transfer, distribution or storage of information contained in this brochure in any form without the prior written consent of Vaisala is strictly prohibited. All specifications – technical included – are subject to change without notice.



HM70 Hand-Held Humidity and Temperature Meter for Spot-Checking Applications



The Vaisala HUMICAP® Hand-Held Humidity and Temperature Meter HM70 is a high-performance, portable humidity reference that is exciting to use.

Features/Benefits

- Multilingual user interface
- Shows measurement trends graphically
- Proven Vaisala HUMICAP® Sensor technology
- 3 probe alternatives, temperature measurement ranges between -70 and +180 °C
- Multiprobe operation; dewpoint and CO₂ probes can also be connected
- 2 probes can be connected simultaneously
- Displays various humidity parameters
- Sensor preheat and chemical purge options for demanding conditions
- NIST traceable (certificate included)

The Vaisala HUMICAP® Hand-Held Humidity and Temperature Meter HM70 is designed for demanding humidity measurements in spot-checking applications. It is also ideal for field checking and calibration of Vaisala's fixed humidity instruments.

The HM70 incorporates the latest generation of the Vaisala HUMICAP® Sensor. It is reliable and has better than ever long-term stability. Additionally, it has a sensor that copes well with chemical interference and provides accuracy that lasts in demanding conditions.

The chemical purge option maintains measurement accuracy in environments with high concentrations of chemicals. The sensor preheat option reduces measurement delays as it keeps the sensor dry when the probe is inserted into hot and humid processes.

Three Probes to Choose from

The HMP75 is a general purpose probe whereas the HMP76 is a long, stainless steel probe especially suitable for spot-checking in ducts. The HMP77 is a small probe at the end of a 5-meter cable. The probe is ideal for difficult-to-reach areas and for on-site calibration of Vaisala's process transmitters.

In addition, the HM70 supports the use of Vaisala's dewpoint, carbon dioxide and moisture in oil probes, allowing measurements in several multiparameter applications.

MI70 Link

The optional MI70 Link Windows® software and the USB connection cable form a practical tool for transferring logged data and real time measurement data from the HM70 to a PC.

Technical Data

HMP75, HMP76 and HMP77 Probes Measured Variables

RELATIVE HUMIDITY	
Measurement range	0 ... 100 %RH
Accuracy (including nonlinearity, hysteresis and repeatability)	
at +15 ... +25 °C (+59 ... +77 °F)	±1 %RH (0 ... 90 %RH)
	±1.7 %RH (90 ... 100 %RH)
at -20 ... +40 °C (-4 ... +104 °F)	±(1.0 + 0.008 x reading) %RH
at -40 ... +180 °C (-40 ... +356 °F)	±(1.5 + 0.015 x reading) %RH
Factory calibration uncertainty (+20 °C / +68 °F)	±0.6 %RH (0 ... 40 %RH)
	±1.0 %RH (40 ... 97 %RH)
	(Defined as ±2 standard deviation limits.)
Response time (90%) at +20 °C (+68 °F) in still air	
HMP75 (with standard plastic grid)	17 s
HMP76 (with standard sintered bronze filter)	60 s
HMP77 (with standard plastic grid and stainless steel netting)	50 s
Sensor	HUMICAP® 180R
	HUMICAP® 180RC (chemical purge, sensor preheat)
Typical long-term stability	better than 1 %RH / year

TEMPERATURE	
Measurement range	
HMP75	-20 ... +60 °C (-4 ... +140 °F)
HMP76	-50 ... +120 °C (-58 ... +248 °F)
short time	-50 ... +180 °C (-58 ... +356 °F)
HMP77	-70 ... +180 °C (-94 ... +356 °F)
Accuracy at +20 °C (+68 °F)	±0.2 °C (±0.36 °F)
Accuracy over temperature range	(see graph)

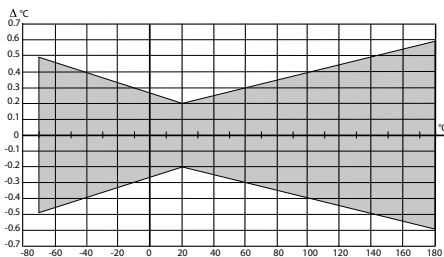

Temperature sensor Pt100 IEC751 1/3 class B

Probe General

Operating temperature range for electronics	-40 ... +60 °C (-40 ... +140 °F)
Housing classification	IP65 (NEMA 4)
Housing material	ABS/PC blend
Probe material	Stainless steel (AISI316L)
Cable length between probe and indicator	1.9 m

MI70 Measurement Indicator Indicator General

Menu languages	English, Chinese, French, Spanish, German, Russian, Japanese, Swedish, Finnish
Display	LCD with backlight, graphic trend display of any parameter, character height up to 16 mm
Max. no. of probes	2
Power supply	Rechargeable NiMH battery pack with AC-adaptor or 4xAA-size alkalines, type IEC LR6 0
Analog output	0... 1 VDC
Output resolution	0.6 mV
PC interface	MI70 Link software with USB or serial port cable
Data logging capacity	2700 points
Alarm	audible alarm function
Operating temperature range	-10 ... +40 °C (+14 ... +104 °F)
Operating humidity range	non-condensing
Housing classification	IP54
Battery operation time	
Continuous use	48 h typical at +20 °C (+68 °F)
Data logging use	up to a month, depending on logging interval
Electromagnetic compatibility	Complies with EMC standard EN61326-1, Portable Equipment

MI70 Indicator + Probe = HM70

ACCESSORIES	
Carrying cases	
for MI70 and HMP75/77 probe	MI70CASE
for MI70 and HMP75/76 probe	MI70CASE2
Transmitter connection cables for	
HMT330 & HMT120/130	211339
HMT310	DRW216050
HMD/W60/70 Series	HMA6070
MI70 Link software with USB cable	219687
MI70 Link software with serial port cable	MI70LINK
Analog output cable	27168ZZ
Sensor protection HMP75	
Plastic PC grid (HMP75 standard)	6221
Membrane filter	10159HM
Sintered bronze filter	DRW212987SP
HMP76/77	
Plastic PPS grid	DRW010276SP
Sintered stainless steel filter	HM47280SP
Sintered bronze filter (HMP76 standard)	DRW212987SP
PPS grid with SS netting (HMP77 standard)	DRW010281SP



For more information, visit www.vaisala.com or contact us at sales@vaisala.com

Ref. B210435EN-C ©Vaisala 2011
This material is subject to copyright protection, with all copyrights retained by Vaisala and its individual partners. All rights reserved. Any logos and/or product names are trademarks of Vaisala or its individual partners. The reproduction, transfer, distribution or storage of information contained in this brochure in any form without the prior written consent of Vaisala is strictly prohibited. All specifications — technical included — are subject to change without notice.



HMI41 Indicator and HMP42/HMP46 Probes

The Vaisala HUMICAP® Humidity Indicator HMI41 fitted with the Vaisala HUMICAP® Humidity and Temperature Probes HMP42 or HMP46 can be used for spot checking and field calibration applications.

In addition to displaying the humidity and temperature readings, the HMI41 indicator calculates dew point and wet bulb temperature, absolute humidity and mixing ratio.

The indicator has an easy-to-read two line liquid crystal display. The display units (metric or non-metric) are easily selected.

These features, plus fast response time, high measurement accuracy and excellent stability, as well as the unique properties of the probe chosen – either the HMP42 or the HMP46 – make the HMI41 indicator and HMP42/46 combination an ideal choice for the most demanding applications.

Features/Benefits

- RH measurement range 0 ... 100 %RH
- Temperature measurement range -40 ... +100 °C (-40 ... +212 °F), with the HMP46 only for short periods up to +180 °C (+356 °F)
- Calculates dew point, wet bulb temperature, absolute humidity and mixing ratio
- Versatile and easy-to-use
- Incorporates Vaisala HUMICAP® Sensor
- Excellent stability
- Data collection with serial line
- NIST traceable (certificate included)
- Optional carrying case and calibration cable

Vaisala HUMICAP® Humidity and Temperature Probe HMP42

The HMP42 probe can be used for spot checking humidity and temperature in applications which require an extremely thin probe. Typically the probe is used for monitoring the drying of structures during construction or after water damage. It is ideal to be used when measuring in any tight places, in ducts or chambers or, for example, under a linoleum floor.

The probe diameter is only 4 mm, allowing access into very small, tight, and hard-to-reach spaces.

Vaisala HUMICAP® Humidity and Temperature Probe HMP46

Typical applications for the HMP46 are plant maintenance, installation and inspection of air conditioning systems, production and storage areas and production processes. The HMP46 operates in full humidity range of 0 ... 100 %RH. The temperature range is from -40 to +100 °C (-40 ... +212 °F). For short periods of time, the probe can withstand temperatures up to +180 °C (+356 °F).

The HMP46 probe is solid and rugged. Its stainless steel probe is made to withstand rough handling in mechanically demanding applications. The probe's long shaft can also reach otherwise unreachable places.

High Performance Sensor

The HMP42/46 probes incorporate Vaisala HUMICAP® Sensor. This sensor has high accuracy, excellent long-term stability and negligible hysteresis. In addition, the sensor is insensitive to dust, particulate dirt and most chemicals.



The Vaisala HUMICAP® Humidity Indicator HMI41 equipped with the Vaisala HUMICAP® Humidity and Temperature Probe HMP42 – an extremely thin probe allowing access into very small, tight, hard-to-reach spaces.



The Vaisala HUMICAP® Humidity Indicator HMI41 equipped with the Vaisala HUMICAP® Humidity and Temperature Probe HMP46 – a rugged stainless steel probe for mechanically demanding and high temperature applications.

Technical Data

HMI41 Indicator

Calculated variables	dew point temperature, absolute humidity, wet bulb temperature, mixing ratio
Resolution	0.1 %RH; 0.1 °C/°F
Power supply	4 batteries, type AA (LR 6)
Battery operation time (alkaline batteries)	72 h continuous use
Auto-off function	
Operating temperature	-20 ... +60 °C (-4 ... +140 °F)
Storage temperature	-40 ... +70 °C (-40 ... +158 °F)
Display	two line LCD
Housing material	ABS plastic
Housing classification	IP53 (with connectors blocked)
Weight (incl. batteries)	300 g
Maximum measurement error of indicator at +20 °C	
humidity	±0.1 %RH
temperature	±0.1 °C (±0.18 °F)

HMP42 Probe

HUMIDITY	
Measurement range	0 ... 100 %RH
Accuracy (incl. non-linearity, hysteresis and repeatability) at +20 °C (+68 °F)	
0 ... 90 %RH	±2 %RH
90 ... 100 %RH	±3 %RH
Factory calibration uncertainty (+20 °C / +68 °F)	
0 ... 15 %RH	±1 %RH
15 ... 78 %RH	±1.5 %RH
Temperature dependence of electronics	±0.05 %RH/°C
Typical long-term stability	better than 1 %RH per year
Response time (90%) at +20 °C in still air	30 s
Sensor HMP42	HUMICAP® MINI

TEMPERATURE	
Measurement range HMP42	-40 ... +100 °C (-40 ... +212 °F)
<i>Temperature accuracy over measurement range</i>	

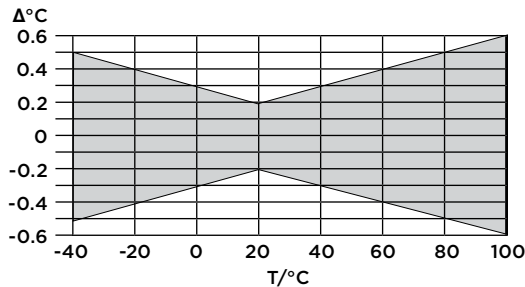

Temperature sensor PT 100 IEC 751 class B

HMP46 Probe

HUMIDITY	
Measurement range	0 ... 100 %RH, non-condensing
Accuracy (incl. non-linearity, hysteresis and repeatability) at +20 °C (+68 °F)	
0 ... 90 %RH	±1 %RH
90 ... 100 %RH	±2 %RH
Factory calibration uncertainty (+20 °C / +68 °F)	
0 ... 15 %RH	±1 %RH
15 ... 78 %RH	±1.5 %RH

Temperature Dependence

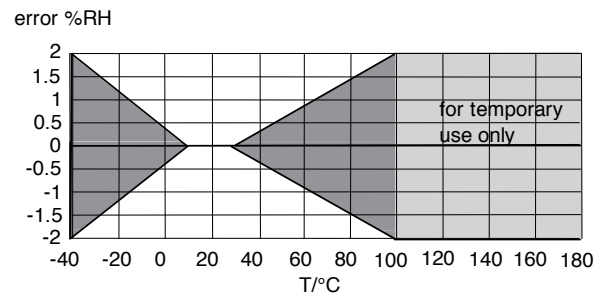

Typical long-term stability	better than 1 %RH per year
Response time (90%) at +20 °C in still air w/sintered filter	15 s
Humidity sensor	HUMICAP® 180

TEMPERATURE	
Continuous measurement	-40 ... +100 °C (-40 ... +212 °F)
Short-term measurement	-40 ... +180 °C (-40 ... +356 °F)
Temperature accuracy at +20 °C (+68 °F)	±0.2 °C (±0.36 °F)

Temperature accuracy over the measurement range

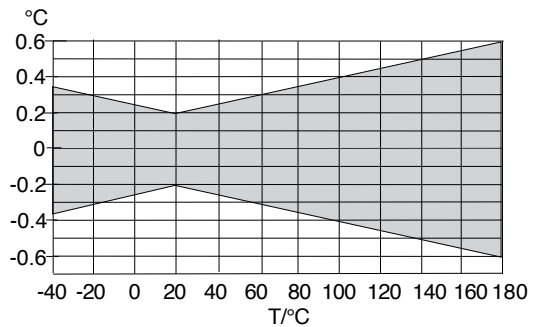

Temperature sensor Pt 100 IEC 751 1/3 class B

Technical Data

General for Probes

Cable length	1500 mm; extended spiral cable
Operating temperature range for electronics	-20 ... +60 °C (-4 ... +140 °F)
Housing material	
electronics housing	ABS plastic
probe	stainless steel
Housing classification	
electronics	IP65 (NEMA 4)
HMP42 sensor protection	
steel grid	19867HM
membrane, tube set (5 pcs)	19858HM
HMP46 sensor protection	
sintered filter	0195
optional membrane filter, (max +80 °C / +176 °F)	10159HM
plastic grid, (max +80 °C / +176 °F)	6221
Weight	
HMP42	200 g
HMP46	450 g
Electromagnetic compatibility	Complies with EMC standard EN61326-1, Portable Equipment.

Accessories

Transmitter calibration cables	
HMT330, HMT120/130	25917ZZ
HMT360	25916ZZ
HMM210	19164ZZ
HMD/W60/70	19116ZZ
Carrying case for HMI41 & HMP42/46	
plastic	210614
aluminum	MI70CASE2
Serial communication cable	19446ZZ
HMP42	
Calibration adapter	HM37067
Rubber sleeve set	19809HM

Dimensions

Dimensions in mm.

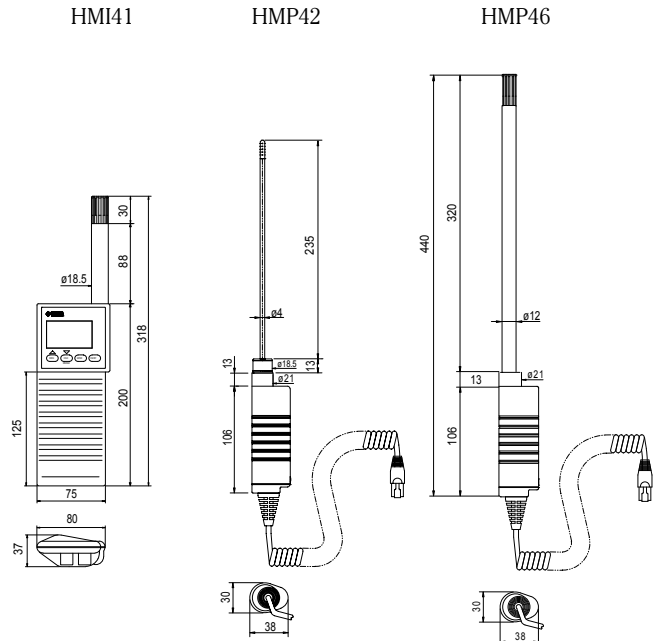

HUMICAP® is a registered trademark of Vaisala.

VAISALA

For more information, visit
www.vaisala.com or contact
us at sales@vaisala.com

Ref. B21114IEN-A ©Vaisala 2011

This material is subject to copyright protection, with all copyrights retained by Vaisala and its individual partners. All rights reserved. Any logos and/or product names are trademarks of Vaisala or its individual partners. The reproduction, transfer, distribution or storage of information contained in this brochure in any form without the prior written consent of Vaisala is strictly prohibited. All specifications — technical included — are subject to change without notice.



Reliable and Cost-efficient HVAC Products

/ HUMIDITY & CO₂

When performance can't be compromised, choose
Vaisala for humidity and CO₂ measurement solutions.



Check out **NEW** products:
www.vaisala.com/HVAC

www.vaisala.com/hvac

VAISALA

HM34 Pocket Size Relative Humidity Meter

The Vaisala HUMICAP® Hand-Held Humidity and Temperature Meter HM34 provides a fast and convenient way to accurately spot-check relative humidity and temperature.

Fast and Easy-to-Use

In measurement mode, the extendable probe just slides out. Normally, measurement takes only a few seconds. The HM34 meter includes a HOLD button which allows the user to retain an RH or T measurement until it has been noted or recorded.

If no buttons are pressed for three minutes, the unit automatically switches itself off. This automatic POWER-OFF function prevents the possibility of accidental discharge of the HM34's battery.

After the measurement is completed, the probe is slid back into the meter casing. Between spot checks, the meter is normally stored in its carrying case.



The Vaisala HUMICAP® Hand-Held Humidity and Temperature Meter HM34 provides accurate spot checks of humidity and temperature.

Features/Benefits

- Ideal for spot checking humidity levels
- Measurement range 0 ... 100 %RH
- Fast response with $\pm 2\%$ accuracy
- Temperature measurement range -20 ... +60 °C (-4 ... +140 °F)
- Lightweight, pocket-sized
- Extendable probe
- Automatic POWER-OFF
- Incorporates Vaisala HUMICAP® Sensor that provides high accuracy, excellent long-term stability, negligible hysteresis, and insensitivity to dust and most chemicals
- Available in either °F or °C
- NIST traceable (certificate included)
- Each unit comes with a 9V battery, attached probe, 0.2 μm protective membrane filter and a carrying case

Technical Data

Relative Humidity

Measurement range	0 ... 100 %RH
Accuracy	±2% (0 ... 90 %RH) ±3% (90 ... 100 %RH)
Resolution	0.1 %RH
Temperature dependence	±0.04 %RH/°C
Sensor type	HUMICAP®H thin film capacitive sensor
Response time (90%)	15 s with membrane filter 5 s with plastic grid

Temperature

Range	-20 ... +60 °C (-4 ... +140 °F)
Accuracy	±0.3 °C (±0.54 °F)
Resolution	0.1 °C (0.1 °F)
Temperature dependence	±0.02 °C/°C (±0.02 °F/°F)
Sensor	Pt 100 IEC 751 1/3 Class B

General

Display	3 1/2 digit LCD
Hold function	Push-button hold of displayed value
Power supply	9 V battery
Battery operation time	50 h
Automatic POWER OFF	after 3 minutes, unless HOLD is activated
Operating temperature range	-20 ... +60 °C (-4 ... +140 °F)
Housing	ABC plastic
Sensor protection	standard plastic grid, part no. 6221 optional sintered filter 133 mm, part no. 0195
Weight	180 g with battery
Ordering Information	HM34C with °C temperature reading HM34F with °F temperature reading
Electromagnetic compatibility	Complies with EMC standard EN61326-1, Portable Equipment

VAISALA

For more information, visit
www.vaisala.com or contact
us at sales@vaisala.com

Ref. B210909EN-B ©Vaisala 2009
This material is subject to copyright protection, with all
copyrights retained by Vaisala and its individual partners. All
rights reserved. Any logos and/or product names are trademarks
of Vaisala or its individual partners. The reproduction, transfer,
distribution or storage of information contained in this brochure
in any form without the prior written consent of Vaisala is strictly
prohibited. All specifications — technical included — are subject
to change without notice.



SHM40 Structural Humidity Measurement Kit

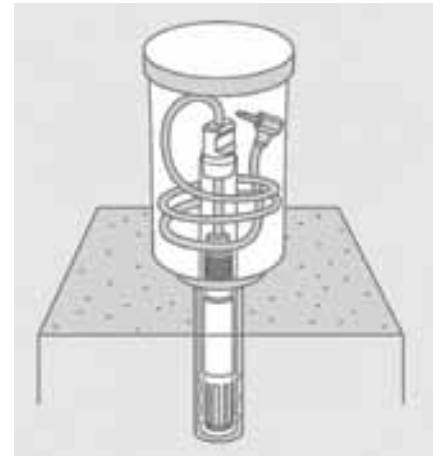

A borehole in concrete and a measurement probe HMP40S inserted in it.



Snapping a connector to the indicator HM40 to read the measurement results.

Vaisala HUMICAP® Structural Humidity Measurement Kit SHM40 offers an easy and reliable solution for humidity measurements in concrete and other structures.

Concrete dries unevenly and is usually drier on the surface, consequently it is important to measure beneath the surface conditions. The borehole method provides information about the humidity profile under the surface. In this method, a humidity probe is left in the borehole until the humidity in the hole has reached an equilibrium state and the stabilized values can be read.

SHM40 Is All You Need for Borehole Humidity Measurement

The Vaisala HUMICAP® Structural Humidity Measurement Kit SHM40 is an ideal solution for the borehole method. The starter kit is comprised of an HMP40S probe, HM40 indicator and accessories for the borehole method in a weather-proof case, optimized for use in harsh and humid construction sites. Additional accessories for the SHM40 can be used to prepare a moisture measurement hole in fresh concrete. Pre-formed holes eliminate the need for drilling and the risk of damaging

heating elements or tubing embedded in the concrete.

Easy Measurement with Multiple HMP40S Probes and Quick Connectors

HMP40S measurement probes are interchangeable. The probes connect easily to the HM40 indicator with a snap-on connector enabling convenient use of multiple probes with one indicator. The measurement data can be displayed in numeric, statistic or graph views.

Features or Benefits

- Easy to use
- Truly interchangeable measurement probes
- Durable
- Accurate measurement data in numeric, statistic or graph views
- Conforms to ASTM standard F2170
- IP65 classified measurement probe and case

Standard Contents of SHM40

- HM40 indicator with adapter
- 1 piece HMP40S RH&T probe with a cable
- 12 pcs plastic tubes (19266HM)
- 12 pcs rubber plugs (233976)
- 3 pcs protective covers with lid (19268HM)
- NIST traceable certificate
- Weather-proof carrying case with a shoulder strap

Technical Data

HMP40S Probe

Relative Humidity

Measurement range	0 ... 100 %RH
Accuracy (incl. non-linearity, hysteresis, and repeatability):	
temperature range	0 °C ... +40 °C
0 ... 90 %RH	± 1.7 %RH
90 ... 100 %RH	± 2.5 %RH
temperature range	-40 °C...0 °C and +40 °C ... +80 °C
0 ... 90 %RH	± 3.0 %RH
90 ... 100 %RH	± 4.0 %RH
Factory calibration uncertainty at +20°C (68°F)	± 1.5 %RH
Humidity sensor	HUMICAP® 180R
Stability	± 2 %RH over 2 years

Temperature

Measurement range	-40 °C ... +80 °C
Accuracy over temperature range:	
0 ... +40 °C	± 0.2 °C
-40 ... 0 °C, +40 ... +80 °C	± 0.4 °C
Temperature Sensor	Pt1000 RTD 1/3 Class B IEC 751

General

Operating temperature range for probe	-40 °C ... +80 °C
Probe weight with standard cable	31 g
Probe housing material	stainless steel
Probe filter and sensor protection	membrane filter with chrome coated ABS plastic
Cable material	Wire PVC / jacket PU
Cable connector	TRRS male 3.5 mm
Probe housing classification	IP65
Borehole diameter needed	16 mm
Measurement depth with standard accessories	min. 30 mm, max. 90 mm

HM40 Indicator

Operation temperature range for indicator	-10 ... +60 °C
Storage temperature range	-30 ... +70 °C
Weight	
Indicator with adapter	240 g
SHM40 case with standard content	3.7 kg
Indicator materials	PC/ABS blend, acrylic display lens
Indicator adapter materials	Nickel plated brass and plastic overmolding
Indicator housing classification	IP54
Mechanical drop endurance	1.0 m without the probe

Power-up time	< 3 s
Alkaline batteries	2 x AA sized, 1.5V (LR6)
Operation time (Alkaline batteries)	typical 100 hours (without backlight)
Calculated variables	Td, Tw, a, x, h
Menu languages	English, German, French, Finnish, Spanish, Swedish, Chinese (simplified), Russian, Japanese
Display	LCD (140 x 160 pixels)
Electromagnetic compatibility (EMC)	European Union directive EN61326-1 for portable equipment

Accessories and Spare Parts

HM40 indicator with adapter and cable probe	HM40S
RH&T probe with cable	HMP40S
HM40 indicator with adapter	HM40SINDI
Quick connection adapter	HM40SADAPTER
Cable for RH&T probe	HMP40SCABLE
Long cable (2.7 m) for RH&T probe	HMP40SCABLE2
Plastic tube set (12 pcs)	19266HM
Rubber plugs (12 pcs)	233976
Protective cover with lid (3 pcs)	19268HM
Weather-proof carrying case with SHM40 filling	233815
USB recharger for HM40 indicator batteries	229249SP
Plastic grid with membrane filter for HMP40S probe	DRW010525
ACCESSORIES FOR WET CONCRETE	
Plastic flange set (12 pcs)	26529HM
Long rubber plug for wet concrete (12 pcs)	26530HM

Dimensions

Dimensions in mm

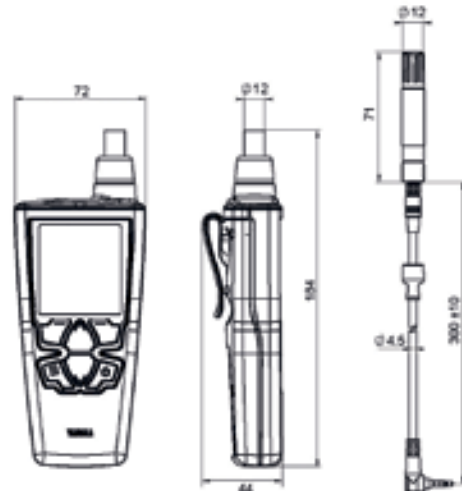

VAISALA

For more information, visit www.vaisala.com or contact us at sales@vaisala.com

Ref. B211187EN-B ©Vaisala 2012
This material is subject to copyright protection, with all copyrights retained by Vaisala and its individual partners. All rights reserved. Any logos and/or product names are trademarks of Vaisala or its individual partners. The reproduction, transfer, distribution or storage of information contained in this brochure in any form without the prior written consent of Vaisala is strictly prohibited. All specifications — technical included — are subject to change without notice.



HMK15 Humidity Calibrator



three step plugs to fit all chamber holes (12 mm, 13.5 mm and 18.5 mm)

transit covers for secure transportation and long-term storage

thermometer with calibration certificate

accepted and reliable method to calibrate humidity instruments. Usually two or three different salt solutions are used. Salts are chosen according to the application.

Certified Salts

The HMK15 can be ordered with certified and pre-measured salts. A sample calibration is made from each batch in Vaisala's Measurement Standards Laboratory (MSL).

Calibrated Thermometer

The HMK15 can be ordered with a thermometer, which is used for measuring the temperature during the calibration. It can also be used for checking the temperature measurement accuracy of the transmitter. The thermometer can contain either mercury (accuracy $\pm 0.3\text{ }^{\circ}\text{C}$ ($\pm 0.54\text{ }^{\circ}\text{F}$)) or red capillary fluid (accuracy $\pm 1.0\text{ }^{\circ}\text{C}$ ($\pm 1.8\text{ }^{\circ}\text{F}$)).

FINAS Approved Measurement Standards Laboratory

Vaisala's Measurement Standards Laboratory is a FINAS accredited calibration laboratory. FINAS is a member of the EA (the European Cooperation for Accreditation).



In addition to laboratory use, Vaisala Humidity Calibrator HMK15 is suitable for on-site checks of humidity probes and transmitters.

Features/Benefits

- Easy and reliable calibration of humidity probes and transmitters
- Based on saturated salt solutions
- Fast temperature equilibration
- No external power required
- Suitable for laboratory use and on-site checks
- Chambers and transit covers make HMK15 easy to transport
- Pre-measured certified salts available
- Vaisala Service Centers offer accredited calibrations for humidity, temperature and barometric pressure.

No measuring instrument stays accurate by itself. It is essential that the functioning of an instrument is periodically checked against a reference. Vaisala has developed the Vaisala Humidity Calibrator HMK15 to make calibration and spot checking of humidity probes and transmitters easy and reliable.

Method Used by Leading Laboratories

The operating principle of the HMK15 is based on the fact that a saturated salt solution generates a certain relative humidity in the air above it. The reading of the humidity probe or transmitter can then be adjusted accordingly. Many leading laboratories use this generally

Technical Data

General

The standard HMK15 consists of the following parts:

Two salt chambers, chamber covers and transit covers

Base plate

Choice of thermometers

mercury thermometer, Vaisala calibrated,
order code 19728HM

thermometer with red capillary liquid, calibrated by
manufacturer, order code 25130HM

Measurement cup and mixing spoon

Options

Certified and ready dosed salts:	Order code:	Total uncertainty*:
-------------------------------------	----------------	------------------------

LiCl salt	11 %RH	19729HM	(±1.3 %RH)
-----------	--------	---------	------------

MgCl ₂ salt	33 %RH	19730HM	(±1.2 %RH)
------------------------	--------	---------	------------

NaCl salt	75 %RH	19731HM	(±1.5 %RH)
-----------	--------	---------	------------

K ₂ SO ₄ salt	97 %RH	19732HM	(±2.0 %RH)
-------------------------------------	--------	---------	------------

*Uncertainties given at +20 °C

Ion exchanged water	19767HM
---------------------	---------

Extra salt chambers	19766HM
---------------------	---------

Carrying bag	HM27032
--------------	---------

VAISALA

For more information, visit
www.vaisala.com or contact
us at sales@vaisala.com

Ref. B210908EN-B ©Vaisala 2011

This material is subject to copyright protection, with all copyrights retained by Vaisala and its individual partners. All rights reserved. Any logos and/or product names are trademarks of Vaisala or its individual partners. The reproduction, transfer, distribution or storage of information contained in this brochure in any form without the prior written consent of Vaisala is strictly prohibited. All specifications — technical included — are subject to change without notice.



HMP155 Humidity and Temperature Probe



HMP155 with an additional temperature probe and optional Stevenson screen installation kit.

Features/Benefits

- Vaisala HUMICAP®180R sensor - superior long-term stability
- Optional warmed humidity probe
- Plug-and-play
- Chemical purge
- USB connection for service use
- Installation kits for DTR13 and DTR502 radiation shields and also for a Stevenson screen
- Weather-proof housing IP66
- New, fast temperature probe
- Different output possibilities: voltage, RS-485, resistive Pt100
- Applications: meteorology, aviation and road weather, instrumentation

New Probe for Reliability

The new Vaisala HUMICAP® Humidity and Temperature Probe HMP155 provides reliable humidity and temperature measurement.

Long-term Stability

The HMP155 has a new generation Vaisala HUMICAP®180R sensor that has excellent stability and withstands well harsh environments. The probe structure is solid and the sensor is protected by default with a sintered teflon filter, which gives maximum protection against liquid water, dust, and dirt.

Warmed Probe and High Humidity Environment

Measuring humidity reliably is challenging in environments where humidity is near saturation. Measurements may be corrupted by fog, mist, rain, and heavy dew. A wet probe may not give an accurate measurement in the ambient air.

This is an environment to which Vaisala has designed a patented, warmed probe for reliable measuring. As the sensor head is warmed continuously, the humidity level inside it stays below the ambient level. Thus, it also reduces the risk of condensation forming on the probe.

Fast Measurements

With its fast response time, the additional temperature probe for the HMP155 is ideal for measurement in environments with changing temperatures. The new membrane filter fastens RH measurement.

Long Lifetime

Protecting the sensor from scattered and direct solar radiation, and precipitation will increase its lifetime. Thus, Vaisala recommends installing the HMP155 in one of the following radiation shields: DTR503, DTR13, or a Stevenson screen. For the additional temperature probe, an installation kit is available to be used with DTR502 radiation shield.

Easy Maintenance

The probe can be calibrated using a pc with a USB cable, with the push buttons, or with the MI70 indicator.



Technical Data

Performance

RELATIVE HUMIDITY

Measurement range	0 ... 100 %RH
Accuracy (incl. non-linearity, hysteresis and repeatability) at	
+15 ... +25 °C (+59 ... +77 °F)	±1 %RH (0 ... 90 %RH) ±1.7 %RH (90 ... 100 %RH)
-20 ... +40 °C (-4 ... 104 °F)	±(1.0 + 0.008 x reading) %RH
-40 ... -20 °C (-40 ... -4 °F)	±(1.2 + 0.012 x reading) %RH
+40 ... +60 °C (+104 ... +140 °F)	±(1.2 + 0.012 x reading) %RH
-60 ... -40 °C (-76 ... -40 °F)	±(1.4 + 0.032 x reading) %RH
Factory calibration uncertainty (+20 °C /+68 °F)	±0.6 %RH (0 ... 40 %RH)* ±1.0 %RH (40 ... 97 %RH)*

* Defined as ±2 standard deviation limits. Small variations possible, see also calibration certificate.

Recommended humidity sensor	HUMICAP®180R(C)
Response time at +20 °C in still air with a sintered PTFE filter	
63 %	20 s
90 %	60 s

TEMPERATURE

Measurement range	-80 ... +60 °C (-112 ... +140 °F)
Accuracy with voltage output at	
-80 ... +20 °C	±(0.226 - 0.0028 x temperature) °C
+20 ... +60 °C	±(0.055 + 0.0057 x temperature) °C
passive (resistive) output according to IEC 751 1/3 Class B	±(0.1 + 0.00167 x temperature) °C
RS485 output	
-80 ... +20 °C	±(0.176 - 0.0028 x temperature) °C
+20 ... +60 °C	±(0.07 + 0.0025 x temperature) °C

Accuracy over temperature range (opposite)

Temperature sensor	Pt100 RTD 1/3 Class B IEC 751
Response time with additional temperature probe in 3 m/s air flow	
63 %	<20 s
90 %	<35 s

OTHER VARIABLES

dewpoint/frost point temperature, wet bulb temperature, mixing ratio

Dimensions

Dimensions in mm

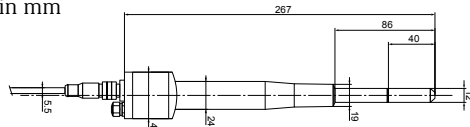

General

Operating temperature range	-80 ... +60 °C (-112 ... +140 °F)
Storage temperature range	-80 ... +60 °C (-112 ... +140 °F)
Connection	8-pin male M12 connector
Connection cables	3.5, 10, and 30 m
Cable material	PUR
Wire size	AWG26
Service cables	USB connection cable MI70 connection cable
Additional T probe cable length	2 m
Housing material	PC
Housing classification	IP66
Sensor protection	sintered PTFE optional membrane filter
Weight (probe)	86 g
Electromagnetic compatibility: Complies with the EMC standard EN61326-1, Electrical equipment for measurement control and laboratory use - EMC requirement for use in industrial locations	

Inputs and Outputs

Operating voltage	7 ... 28 VDC*
-------------------	---------------

*Note: minimum operating voltage 12 V with 0 ... 5 V output and 16 V with 0 ... 10 V output, probe heating, chemical purge or XHEAT.

Outputs

voltage output	0 ... 1 V, 0 ... 5 V, 0 ... 10 V
resistive Pt100 (4-wire connection) RS485	

Average current consumption (+15 VDC, load 100 kOhm)

0 ... 1 V output	<3 mA
0 ... 10 V output	+0.5 mA
RS485	<4 mA
during chemical purge with warmed probe	max. 110 mA max. 150 mA

Settling time at power-up

voltage output	2 s
RS485	3 s

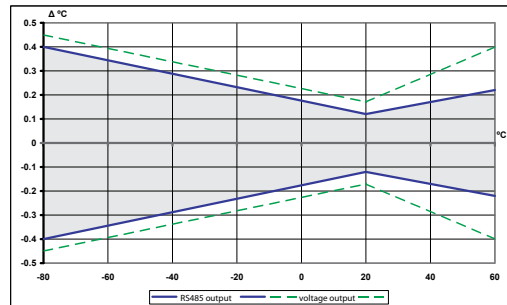

VAISALA

For more information, visit www.vaisala.com or contact us at sales@vaisala.com

Ref. B210752EN-D ©Vaisala 2011

This material is subject to copyright protection, with all copyrights retained by Vaisala and its individual partners. All rights reserved. Any logos and/or product names are trademarks of Vaisala or its individual partners. The reproduction, transfer, distribution or storage of information contained in this brochure in any form without the prior written consent of Vaisala is strictly prohibited. All specifications — technical included — are subject to change without notice.



DTR500 Solar Radiation and Precipitation Shields



The Vaisala Solar Radiation Shield Series DTR500 are available in either a 5-, 9- or 12-plate models.

The Vaisala Radiation Shield Series DTR500 are solar radiation and precipitation shields supporting humidity probe installations in outdoor applications.

Shield Protects Sensor

The maintenance-free DTR500 series shields protect the humidity and temperature sensors from solar radiation and precipitation. They provide excellent ventilation while blocking both direct and reflected solar radiation.

The special plastic used in the plates has excellent thermal characteristics; the white outer surface reflects radiation; the black inside absorbs accumulated heat. The shields can be easily installed on either a vertical pole, horizontal beam, or a flat surface.

The DTR Shields can be used with the following Vaisala probes:

- Vaisala HUMICAP® Humidity and Temperature Probe HMP155
- Vaisala HUMICAP® Humidity and Temperature Transmitter HMT337
- Vaisala HUMICAP® Humidity and Temperature Transmitters HMT120/130
- Vaisala INTERCAP® Humidity and Temperature Transmitter HMP60
- Vaisala HUMICAP® Humidity and Temperature Transmitter HMP110

Choice of Models and Installation Accessories

Three models are available:

- Five-plate shield: Vaisala Radiation Shield DTR504 for horizontal beam installation and DTR504A including pole mast installation kit for HMT120/130 remote probes, HMP60 and HMP110.

- Nine-plate shield: Vaisala Radiation Shield DTR502B for HMT337, PTU300 and HMP155's additional T probe
- Twelve plate shield: Vaisala Radiation Shield DTR503A for HMP155

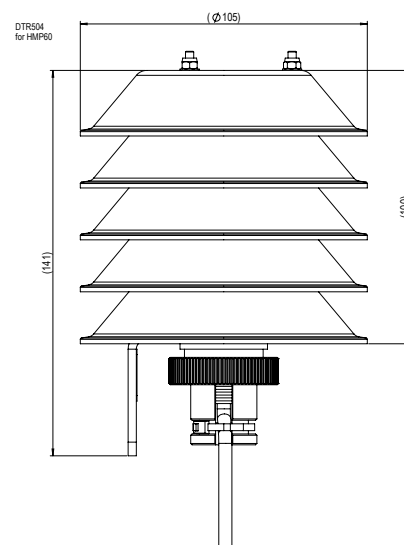

DTR504 for HMP60, HMP110 and HMT120/130 remote probes. Refer to drawings of DTR502B for dimensions of DTR504A pole mast installation accessory.

Features/Benefits

- Protects temperature and humidity probes from scattered, as well as, direct solar radiation and rain.
- Maintenance-free
- Naturally ventilated
- Installs easily on a vertical pole, horizontal beam or flat surface
- Suitable for a wide range of applications
- Choice of shields and mounting accessories

Technical Data

Dimensions

Dimensions in mm.

DTR502B
for HMT337 and PTU300

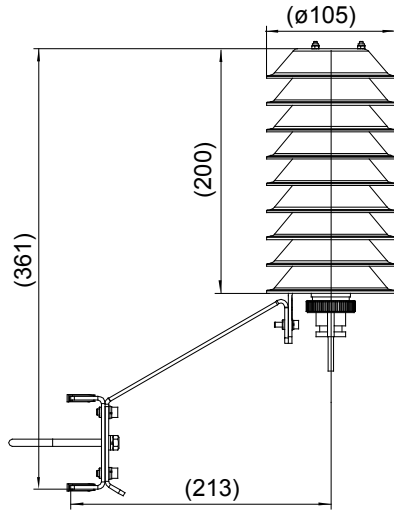

DTR502B pole mast installation.

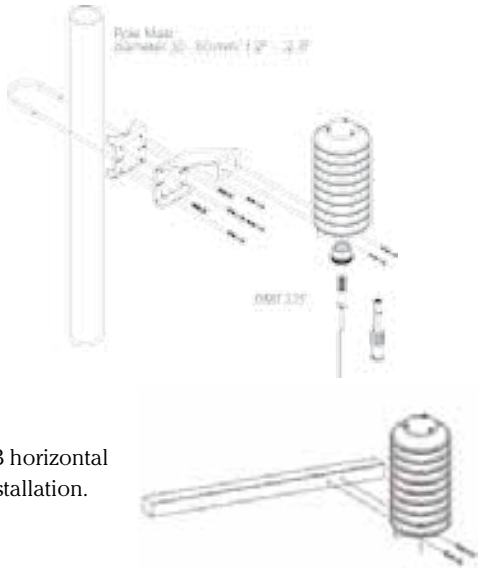

DTR502B horizontal beam installation.

Dimensions

Dimensions in mm.

DTR503A
for HMP155

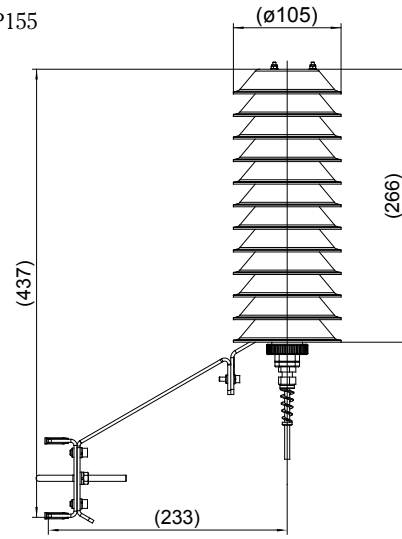

DTR503A pole mast installation.

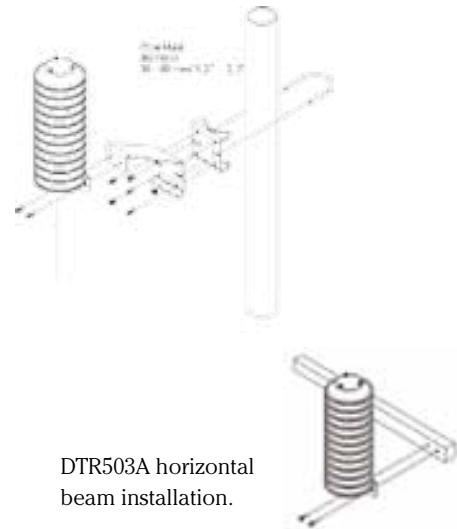

DTR503A horizontal beam installation.



For more information, visit www.vaisala.com or contact us at sales@vaisala.com

Ref. B210906EN-C ©Vaisala 2011
This material is subject to copyright protection, with all copyrights retained by Vaisala and its individual partners. All rights reserved. Any logos and/or product names are trademarks of Vaisala or its individual partners. The reproduction, transfer, distribution or storage of information contained in this brochure in any form without the prior written consent of Vaisala is strictly prohibited. All specifications — technical included — are subject to change without notice.



HMT330MIK Meteorological Installation Kit

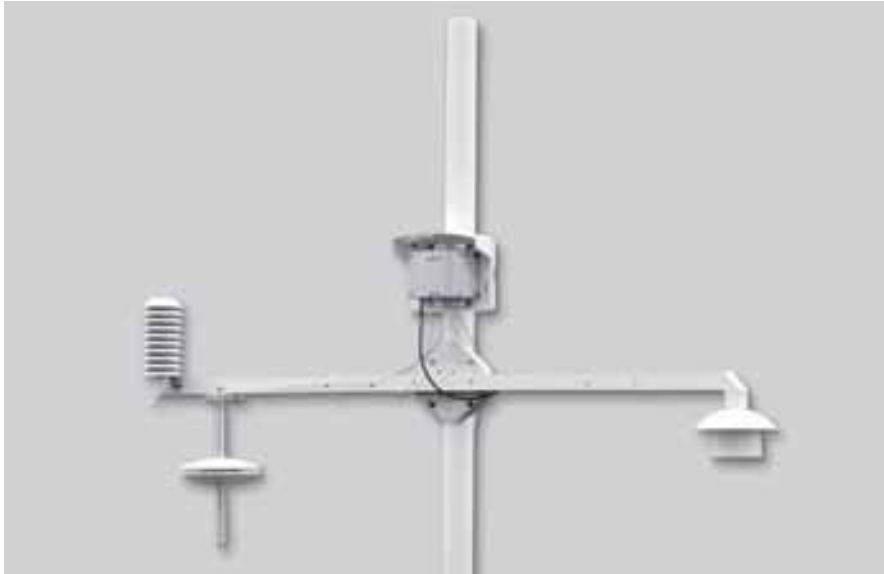

The HMT337 and PTU307 feature warmed probe technology. Installed with the HMT330MIK kit either one forms the right choice for reliable humidity measurement in humid weather conditions.

Features/Benefits

- For outdoor humidity and temperature measurements
- Can be ordered in a variety of configurations
- Used together with HMT337 transmitter or PTU307
- Vaisala SPH 10/20 Static Pressure Head eliminates effectively pressure variations in the barometer caused by wind

HMT337/PTU307 Features

- Warmed probe provides true humidity readings in condensing conditions
- Humidity measurement expressed as relative humidity and/or dewpoint temperature
- Easy field calibration with the HM70 hand-held meter

The Vaisala Meteorological Installation Kit HMT330MIK enables the Vaisala HUMICAP® Humidity and Temperature Transmitter HMT337 to be installed outdoors to obtain reliable measurements for meteorological purposes.

True Humidity Readings in Condensing Conditions

In weather observations dew formation makes reliable humidity measurement difficult. When dew has formed on the humidity sensor, it is impossible to obtain a true reading until this dew evaporates.

Both the PTU307 and HMT337 avoid this problem by warming the probe. When warmed, the relative humidity inside the probe stays below the ambient level. With an accurate temperature measurement, the ambient dewpoint can be calculated precisely. To obtain the ambient relative humidity, an additional probe measures the ambient temperature,

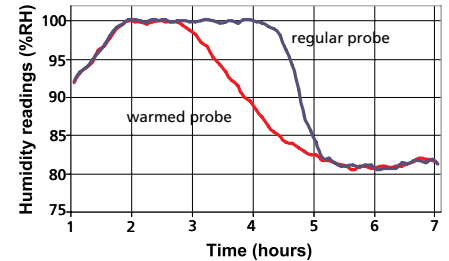

After a period of 100 % relative humidity, the warmed probe measures the true humidity, whereas the non-warmed probe takes time to recover from the condensation.

and the transmitter calculates the relative humidity from the dewpoint and temperature values.

Open Shield Prevents Microclimates

The warmed probe of the HMT337/PTU307 is mounted in a shield which is open at the bottom to ensure steady air circulation to the sensor even in calm weather.

In traditional radiation shields sleet or snow can accumulate on the shield and prevent the proper air circulation through the shield, and create a humid microclimate until the snow melts.

Essential for Critical Weather Measurements

Obtaining a true humidity reading is particularly important e.g. in traffic safety: at airports and at sea as well as on the roads. It is essential, for example, in fog and frost prediction.



For calibration, a portable HMP77 reference probe is easy to attach beside the HMT337 or PTU307 probe.

Technical Data

Dimensions

Dimensions in mm (inches)

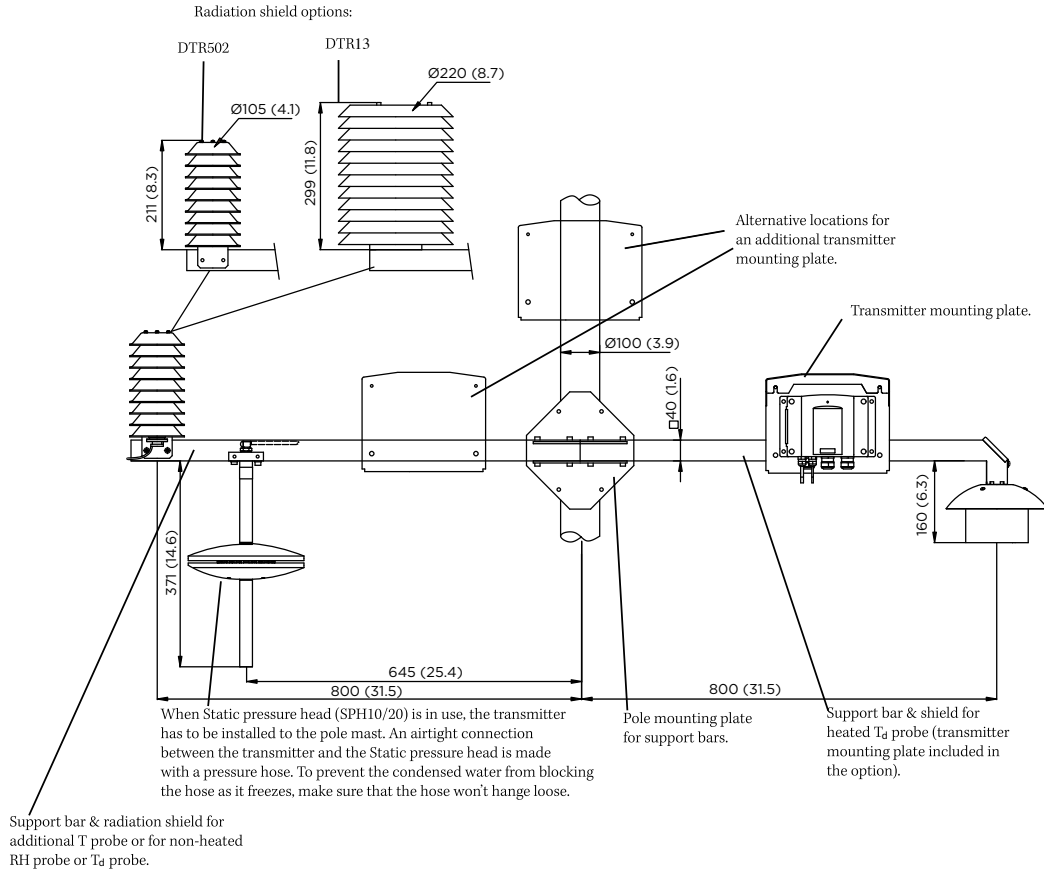

Order form

Vaisala Meteorological Installation Kit		HMT330MIK			
Support bar & shield for warmed Td probe	No support bar & shield for warmed Td probe	0			
	<i>Support bar, transmitter mounting plate & shield for warmed Td probe</i>	1			
Support bar and radiation shield for additional T probe or for non-warmed RH or Td probe	No support bar or radiation shield		A		
	<i>Support bar with DTR502 shield for T probe</i>		B		
	<i>Support bar with DTR13 shield for T probe</i>		C		
	<i>Support bar with DTR502 shield for non-warmed RH or Td probe</i>		D		
	<i>Support bar with DTR13 shield for non-warmed RH or Td probe</i>		E		
Support bar mounting plate	No mounting plate	0			
	<i>Pole mounting plate for support bar/bars</i>	1			
Additional transmitter mounting plate	No additional transmitter mounting plate		A		
	<i>Transmitter mounting plate for support bar assembly</i>		B		
	<i>Transmitter mounting plate for pole assembly</i>		C		
Static Pressure Head	No Static Pressure Head	0			
	<i>Static Pressure Head SPH10</i>	1			

HUMICAP® is a registered trademark of Vaisala.



For more information, visit www.vaisala.com or contact us at sales@vaisala.com

Ref. B210944EN-C ©Vaisala 2011
This material is subject to copyright protection, with all copyrights retained by Vaisala and its individual partners. All rights reserved. Any logos and/or product names are trademarks of Vaisala or its individual partners. The reproduction, transfer, distribution or storage of information contained in this brochure in any form without the prior written consent of Vaisala is strictly prohibited. All specifications — technical included — are subject to change without notice.



HMT300TMK Turbine Mounting Kit for Power Turbine Intake Air Measurement



The Vaisala HUMICAP® Turbine Mounting Kit HMT300TMK is shown with the cover open and HMT337 Humidity and Temperature Transmitter installed. (Not included in the HMT300TMK.)

The Vaisala HUMICAP® Turbine Mounting Kit HMT300TMK is developed to monitor the air intake of gas and liquid fueled power turbines. HMT300TMK is used together with HMT337 Temperature and Humidity Transmitter.

Features/Benefits

- Designed for high humidity applications
- Measurement range: -40 ... +100°C
- Patented, warmed probe
- Incorporates Vaisala HUMICAP® Sensor for excellent accuracy and long-term stability and resistance to dust and most chemicals
- Low maintenance need
- Outer cover provides protection from rain and direct sunlight
- NIST traceable (certificate included)

It is ideal for measuring in water vapor injection applications because the sensor has been optimized for high humidity environments by utilizing a patented, warmed probe. Water vapor is added to the intake of the turbine to increase the mass flow which in turn increases compression and electrical power output.

Low Maintenance

Power turbines also require exact water vapor injection in the chamber to reduce pollutant emissions. Vaisala's warmed probe technology is ideal because of its reliability in the field. In fact, the only suggested scheduled maintenance is annual calibration.

Patented, Warmed Probe Prevents Condensation

The HMT300TMK with the HMT337 installed, provides fast and reliable dewpoint measurement especially under high humidity conditions where dew would normally form

on the humidity sensor and thereby cause errors in measurement. The patented warmed probe prevents condensation from forming on the sensor.

Protective Enclosure

The HMT300TMK includes a white, painted stainless steel enclosure with an installation kit for the probe. The HMT337 Humidity and Temperature Transmitter is installed in the stainless steel enclosure at the factory, when ordered together with HMT300TMK. The instrument can be equipped to be powered with either 24 VDC/VAC or with an internal 110/230 volt power supply unit.

The outer cover protects the transmitter from direct sun light and rain. The installation kit protects the probe from outer water splashes, keeps the sensor dry, and prevents any parts that could vibrate loose from entering the turbine.

The HMT300TMK can be ordered separately for installation with the customer's existing HMT337.

HUMICAP® Performance

The HMT330 Series Transmitters are fitted with the latest generation of the HUMICAP®, the polymer sensor known for its accuracy, reliability and long-term stability. The sensor has a high tolerance for particulate abrasion and chemical contamination.

Vaisala HUMICAP® Humidity and Temperature Transmitter HMT337

The HMT337 is intended for demanding industrial humidity measurement applications with a risk of condensation. The stainless steel probe is mechanically durable and preferred for most industrial applications.

Technical Data

Dewpoint Temperature

Measurement range -40 ... +100 °C (-40 ... +212 °F)

Accuracy: find the intersection of the dewpoint temperature curve and the dewpoint difference reading (process temperature - dewpoint temperature) on the x-axis and read the accuracy in dewpoint measurement at the y-axis

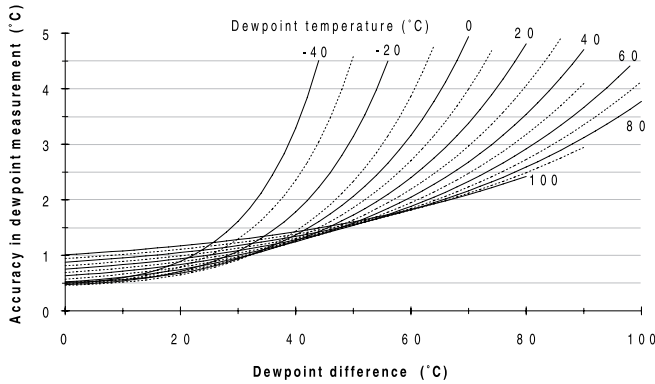

Response time (90 %) at +20 °C (68 °F) in still air (PPS grid with steel netting) 20 s
 Sensor HUMICAP® 180C

General

Connections screw terminals for 0.5 mm² wires (AWG 20), stranded wires recommended
 Operating voltage 24 VDC/VAC (20...28 V) or 115/230 VAC (Must be specified at time of order)
 Recommended external load for current outputs < 500 ohm
 0...1 V output > 2 kohm (to ground)
 0...5 & 0...10 V outputs > 10 kohm (to ground)
 Operating temperature range for electronics -40...+60 °C (-40 ... +140 °F)
 Storage temperature -55...+80 °C (-67 ... +176 °F)
 Housing material G-AlSi10 (DIN 1725)
 Housing classification IP65 (NEMA 4)
 Bushing 8...11 mm diameter cables (0.31 ... 0.43 inch)
 Humidity sensor protection (Ø 12 mm) PPS grid with steel netting
 Weight:
 HMT300TMK with HMT337 8,7 kg
 HMT300TMK with HMT337, packed in a wooden shipping box 13,3 kg
 Electromagnetic compatibility Complies with EMC standard EN61326-1, Industrial Environment

Outputs

Two standard outputs, third optional 0...20 mA, 4...20 mA, 0 ... 1 V, 0...5 V, 0 ... 10 V
 Typical accuracy of analog output at +20 °C (+68 °F) ±0.05 % full scale
 Typical temperature dependence of analog output ±0.005 %/°C full scale
 Serial output available RS232C (optional RS485)

Dimensions

Dimensions in mm (inches)

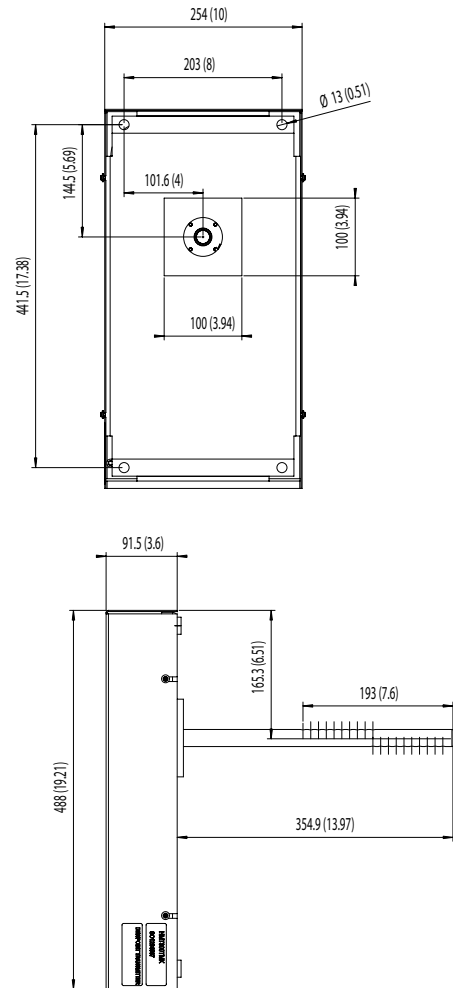

HUMICAP® is a registered trademark of Vaisala.



For more information, visit www.vaisala.com or contact us at sales@vaisala.com

Ref. B210680EN-C ©Vaisala 2011
 This material is subject to copyright protection, with all copyrights retained by Vaisala and its individual partners. All rights reserved. Any logos and/or product names are trademarks of Vaisala or its individual partners. The reproduction, transfer, distribution or storage of information contained in this brochure in any form without the prior written consent of Vaisala is strictly prohibited. All specifications — technical included — are subject to change without notice.



DMT340 Series Dewpoint and Temperature Transmitters for Very Dry Conditions

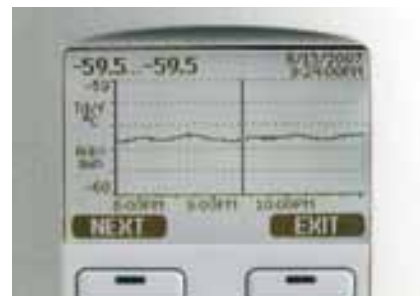

The display shows measurement trends, real time data and history.

Features/Benefits

- Measures dew points from -60 °C to +80 °C (-76 ... +176 °F) with the accuracy of ± 2 °C (± 3.6 °F)
- Vaisala DRYCAP® Sensor provides accurate, reliable measurement with excellent long-term stability and fast response
- Withstands condensation
- Unique auto-calibration feature
- Optional alarm relays, local display and mains power supply module
- Compatible with Vaisala DRYCAP® Hand-Held Dewpoint Meter DM70
- NIST traceable (certificate included)
- 3 analog outputs and a serial interface, WLAN/LAN
- Modbus protocol support (RTU/TCP)

The Vaisala DRYCAP® Dewpoint and Temperature Transmitter Series DMT340 is designed for industrial low humidity applications. Typical applications include compressed air drying and metal treatment. The device is very reliable, easy to use and economical to maintain.

Stability in Low Dew Points

The Vaisala DRYCAP® Sensor is immune to particulate contamination, water condensation, oil vapor and most chemicals. Since the sensor withstands condensation, its performance is unmatched for low dew point applications that experience water spikes in the process. The sensor recovers rapidly from contact with free water.

Patented Auto-Calibration

The stability of the DMT340 is due to the unique auto-calibration

function, patented by Vaisala. The auto-calibration makes the transmitter perform a calibration and adjustment by itself while the measured process is running. If the measurement accuracy is not confirmed, corrections are made automatically. The procedure is so quick and corrections are so minor that it will go unnoticed. This ensures low maintenance and high performance. To continue performance at the highest level, the transmitter can be sent to Vaisala for a NIST traceable calibration. Calibration intervals depend on the application; in normal conditions, a NIST traceable calibration in every two years is recommended.

Graphical Measurement Trend and History Display

The DMT340 can be ordered with a large numerical and graphical display with a multilingual menu. It allows

the user to monitor measurement trends and one-year history. The optional data logger with real-time clock makes it possible to generate more than four years of measured history and zoom in on any desired time or time frame. The display alarm allows tracking of any measured parameter, with a freely configurable low and high limit.

Versatile Outputs and (Wireless) Data Collection

The DMT340 can be connected to a network with an optional (W)LAN interface, which enables a (wireless) Ethernet connection.

For serial interface also the USB connection, RS232 and RS485 can be used. Additionally an alarm relay option is available.

The transmitter can have up to three analog outputs. Galvanic isolation of supply power and analog outputs are also offered.

The recorded measurement data can be viewed on the display or transferred to a PC with Microsoft Windows® software.

Easy Installation

The DMT340 has a variety of features to choose from. Units are delivered installation-ready.



The Vaisala DRYCAP® HandHeld Dewpoint Meter DM70 is ideal for field checking DMT340 transmitters.



The DMT342 probe is installed using a flange or sampling cell. The small probe is ideal for integrating into larger equipment.

Probe Specifications

DMT342 with Small Size Flanged Probe

Pressure range	0 ... 50 bar/0 ... 725 psia
Mechanical durability	up to 250 bar/ 3625 psia
Probe diameter	12 mm/0.5 inch
Installation	
Flange	36 mm/1.4 inch
Sampling cell	HMP302SC

Dimensions

Dimensions in mm (inches)

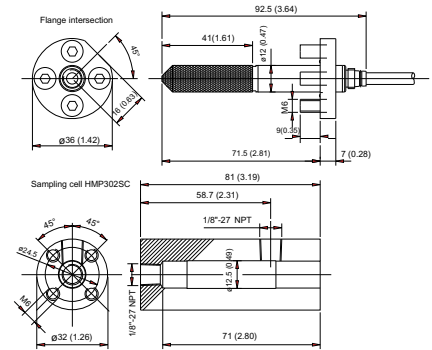

The DMT344 features a threaded connection for extended pressures with different fitting body options. It is ideal for permanent installations into pressurized or vacuum processes.

Probe Specifications

DMT344 with Probe for High Pressures

Pressure range	0 ... 50 bar/0 ... 725 psia
Mechanical durability	up to 100 bar/ 1450 psia
Probe diameter	12 mm/0.5 inch
Installation	
Fitting Body	M22 x 1.5
Fitting Body	NPT 1/2"

Dimensions

Dimensions in mm (inches)

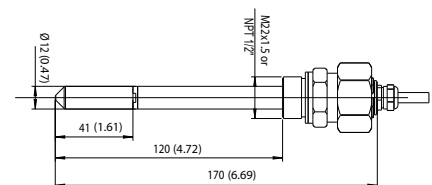



The DMT347 probe is ideal for tight spaces with thread connection. The small probe is installed using the Swagelok® connectors.

Probe Specifications

DMT347 with Small Sized Probe

Pressure range	0 ... 10 bar/0 ... 145 psia
Mechanical durability	up to 10 bar/ 145 psia
Probe diameter	12 mm/0.5 inch
Installation	
Fitting Body	R 3/8" ISO
Fitting Body	G 1/2" ISO
Fitting Body	NPT 1/2"

Dimensions

Dimensions in mm (inches)

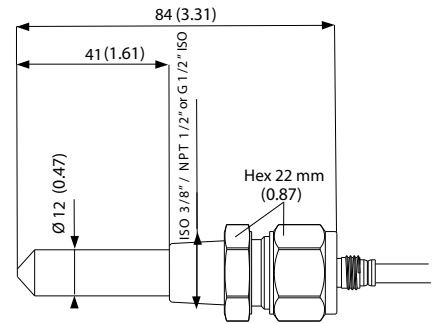

The DMT348 is ideal for installations in pressurized processes where the probe needs to be removed while the process is running. The probe depth is adjustable.

Probe Specifications

DMT348 with Probe for Pipeline Installations

Pressure range	0 ... 40 bar/0 ... 580 psia
Adjustable length	41 ... 149/371 mm/ 1.61 ... 5.87/14.6 inch
Installation	
Fitting Body	R1/2" ISO
Fitting Body	NPT 1/2"
Ball Valve Set	BALLVALVE-1
Sampling Cell	DMT242SC or DMT242SC2

Dimensions

Dimensions in mm (inches)

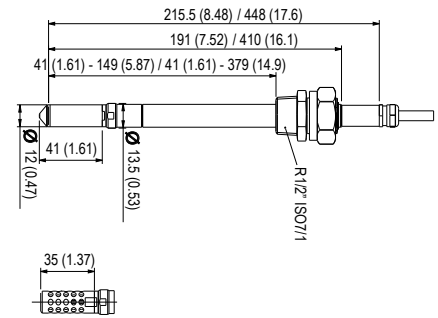

Optional filter for low pressures
(for all models)

Technical Data

Measured Parameters

DEW POINT	
Sensor	Vaisala DRYCAP®180M
Measurement range	-60 ... +80 °C (-76 ... +176 °F) Td
For continuous use	-60 ... +45 °C (-76 ... +113 °F) Td
Accuracy	±2 °C/±3.6 °F see the accuracy graph below
up to 20 bar/290 psia	additional inaccuracy +1 °C Td
20 ... 50 bar/290 ... 725 psia	

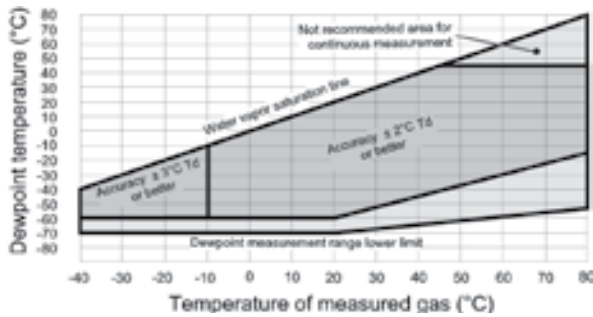

Dew point accuracy vs. measurement conditions	
Response time	63% [90%] at +20°C gas temperature
Flow rate	1 l/min and 1 bar pressure
-60 ... -20 °C Td (-76 ... -4 °F Td)	5s [10s]
-20 ... -60 °C Td (-4 ... -76 °F Td)	45s [10min]

TEMPERATURE	
Measurement range	0 ... +80 °C (+32 ... +176 °F)
Accuracy	±0.2 °C at room temperature
Temperature sensor	Pt 100 IEC 751 1/3 class B
RELATIVE HUMIDITY	
Measurement range	0 ... 70 %RH
Accuracy (RH < 10 %RH, at +20 °C)	±0.004 %RH + 20 % of reading
PPM	
Measurement range (typical)	10 ... 2500 ppm
Accuracy (at +20 °C, 1 bar)	1 ppm + 20 % of reading
Other measurement parameters available (depends on model) mixing ratio, absolute humidity, pressure dew point calculated to 1 bar, temperature difference (T-Td), water vapor pressure	

Operating Environment

Operating temperature	
for probes	-40 ... +80 °C (-40 ... +176 °F)
Mechanical durability	Up to +180 °C (+356 °F)
for transmitter body	-40 ... +60 °C (-40 ... +140 °F)
with display	0 ... +60 °C (+32 ... +140 °F)
Storage temperature range	-55 ... +80 °C (-67 ... +176 °F)
Pressure range for probes	See probe specifications
Sample flow rate	No effect
Measured gases	non corrosive
Complies with EMC standard EN61326-1, Electrical equipment for measurement, control and laboratory use - EMC requirements;	
Industrial environment.	

Inputs and Outputs

Operating voltage	10 ... 35 VDC, 24 VAC
with optional power supply module	100 ... 240 VAC 50/60 Hz
Power consumption @ 20 °C (U _{in} 24VDC)	
RS-232	max 25 mA
U _{out} 2 x 0...1V / 0...5V / 0...10V	max 25 mA
I _{out} 2 x 0...20 mA	max 60 mA
display and backlight	+ 20 mA
during sensor purge	+ 110 mA max
Analog outputs (2 standard, 3rd optional)	
current output	0 ... 20 mA, 4 ... 20 mA
voltage output	0 ... 1 V, 0 ... 5 V, 0 ... 10 V
Accuracy of analog outputs at 20 °C	0.05 % full scale
Temperature dependence of the analog outputs	± 0.005 %/°C full scale
External loads	
current outputs	R _L < 500 ohm
0 ... 1V output	R _L > 2 kohm
0 ... 5V and 0 ... 10V outputs	R _L > 10 kohm
Max wire size	0.5 mm ² (AWG 20) stranded wires recommended
Digital outputs	RS-232, RS-485 (optional)
Service connection	RS-232, USB
Relay outputs	0.5 A, 250 VAC, SPDT (optional)
Ethernet interface (optional)	
Supported standards	10/100Base-T
Connector	RJ45
Protocols	Telnet
WLAN interface (optional)	
Supported standards	802.11b
Antenna connector type	RP-SMA
Protocols	Telnet
Security	WEP 64/128, WPA
Authentication / Encryption	
Open / no encryption	
Open / WEP	
WPA Pre shared key / TKIP	
WPA Pre shared key / CCMP (a.k.a. WPA2)	
Optional data logger with real-time clock	
Logged parameters	max. three with trend/min/max values
Logging interval	10 sec (fixed)
Max. logging period	4 years 5 months
Logged points	13,7 million points per parameter
Battery lifetime	min. 5 years
Display	LCD with backlight, graphic trend display of any parameter
Display menu languages	English, Chinese, Spanish, German, French, Japanese, Russian, Swedish, Finnish

Mechanics

Cable bushing	M20x1.5 for cable diameter 8 ... 11mm/0.31 ... 0.43"
Conduit fitting	1/2"NPT
User cable connector (optional)	M12 series 8 pin (male)
option 1	with plug (female) with 5 m / 16.4 ft black cable
option 2	with plug (female) with screw terminals
USB-RJ45 Serial Connection Cable	order no. 219685
Probe cable diameter	5.5 mm
Probe cable lengths	2 m, 5 m or 10 m
Housing material	G-AISI 10 Mg (DIN 1725)
Housing classification	IP 65 (NEMA 4X)

Dimensions

Dimensions in mm (inches)

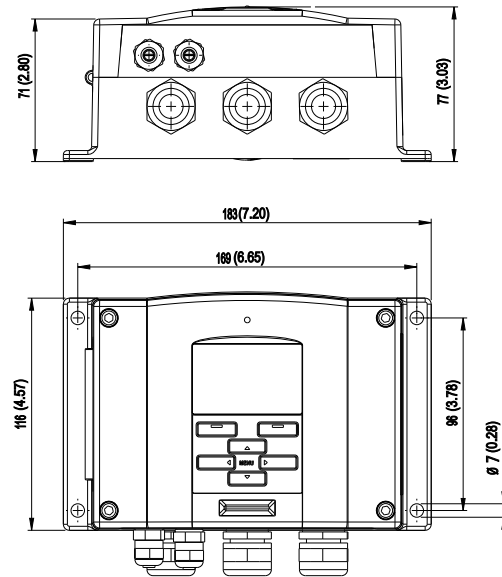

DRYCAP® is a registered trademark of Vaisala.



TYPE APPROVED PRODUCT
CERTIFICATE NO.: A-11440

VAISALA

For more information, visit
www.vaisala.com or contact
us at sales@vaisala.com

Ref. B210952EN-B ©Vaisala 2011
This material is subject to copyright protection, with all
copyrights retained by Vaisala and its individual partners. All
rights reserved. Any logos and/or product names are trademarks
of Vaisala or its individual partners. The reproduction, transfer,
distribution or storage of information contained in this brochure
in any form without the prior written consent of Vaisala is strictly
prohibited. All specifications — technical included — are subject
to change without notice.



Ensure dry compressed air with dewpoint measurement

Vaisala innovated DRYCAP® dewpoint instruments have been developed for the most demanding conditions.

- Fastest wet-to-dry response time on the market - just minutes
- High resistance to contamination - immune to compressor oil
- Complete recovery from saturated conditions
- Long 2-year calibration interval

Want to know more? Our experts welcome your most difficult questions.



DMT345 and DMT346 Dewpoint Transmitters for High Temperature Applications



The Vaisala DRYCAP® Dewpoint Transmitters DMT345 and DMT346 are designed to measure and control humidity especially in dry environments with high temperatures.

Features/Benefits

- The DMT345 measures humidity in temperatures up to 180 °C (356 °F)
- The DMT346 measures humidity in temperatures up to 350 °C (+662 °F)
- Dew point accuracy ± 2 °C (± 3.6 °F)
- Vaisala DRYCAP® Sensor provides accurate, reliable measurement with excellent long-term stability and fast response
- Withstands condensation
- Unique auto-calibration feature
- Optional local display with keypad, mains power supply module and alarm relays
- NIST traceable calibration (certificate included)
- Analog outputs, WLAN/LAN
- Modbus protocol support (RTU/TCP)

The Vaisala DRYCAP® Dewpoint Transmitters DMT345 and DMT346 are designed for humidity measurement in industrial drying applications with particularly high temperatures.

Both transmitters incorporate the Vaisala DRYCAP® sensor, which is accurate, reliable, and stable. The sensor withstands condensation and is immune to particulate contamination, oil vapor and most chemicals. The DRYCAP® sensor stands out for its swift response time and rapid recovery after getting wet.

Measure Humidity Directly in Hot Processes

The DMT345 and DMT346 are constructed for direct measurement in hot processes. Therefore, there is no need for sampling systems and trace heating. As a result, high accuracy and constancy are maintained.

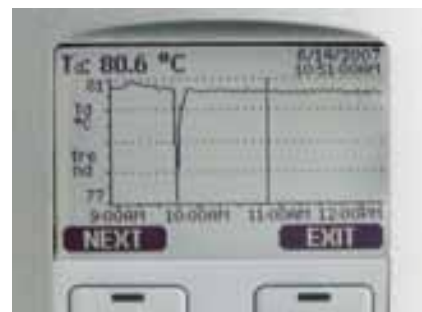

The large and clear display allows the user to check data at a glance.

The accuracy and stability of the DMT345 and the DMT346 are due to the unique auto-calibration function, patented by Vaisala. This auto-calibration makes the transmitter perform a calibration and adjustment by itself while the measured process is running. If the measurement accuracy is not confirmed, corrections are made automatically. The procedure is so quick and corrections are so minor that it will go unnoticed. This ensures low maintenance and high performance. In normal conditions, it is recommended to have a traceable calibration performed once a year.

DMT345, Accurate in Hot and Dry Environments

The DMT345 is designed for accurate humidity measurement in hot and dry conditions. This model provides unmatched dry end measurement accuracy in temperatures up to 140 °C, however the DMT345 can operate safely in temperatures up to 180 °C.

The stainless steel probe is especially designed for high temperatures and has an optional installation flange that allows an adjustable installation depth and therefore a precise positioning.

DMT346, Reliable in Very Hot Processes

When process temperatures range between 140 °C to 350 °C, the DMT346 provides the best measurement performance.

The DMT346 comes with a cooling set as a standard feature. The cooling effect may be regulated by adding the cooling fins, or removing them from the set for the best measurement performance.

The cooling system operates without moving parts, additional power or cooling utilities, thereby eliminating the risk of sensor damage due to a mechanical cooling failure.

Additionally, sensor warming minimizes the risk of condensing on the sensor. In low humidity the combination of auto-calibration and DRYCAP® ensures accurate measurement.

Graphical Display

The DMT345 and DMT346 transmitters can be ordered with a large numerical and graphical display, which allows the user to clearly monitor operational data, measurement trends and up to one-year measurement history.

The optional data logger with real-time clock makes it possible to generate more than four years of the measured history and zoom in on any desired time or time frame.

Versatile Outputs and (Wireless) Data Collection

The transmitter can be connected to a network with an optional (W)LAN interface, which enables a (wireless) Ethernet connection.

For serial interface also the USB connection, RS232 and RS485 can be used. Additionally an alarm relay option is available.

The transmitter can have up to three analog outputs. Galvanic isolation of supply power and analog outputs are also offered. The recorded measurement data can be viewed on the display or transferred to a PC with Microsoft Windows® software.

DMT345-346 is also capable in applying the MODBUS communication protocol and together with an appropriate connection option provides either MODBUS RTU (RS485) or MODBUS TCP/IP (Ethernet) communication.

Units are delivered installation-ready.

Technical Data

Measured Variables DMT345

DEWPOINT DMT345

Sensor	Vaisala DRYCAP®180S
Measurement range	-40 ... +100 °C (-40 ... +212 °F) Td
Accuracy	±2°C (±3.6 °F) Td

See the accuracy graph below

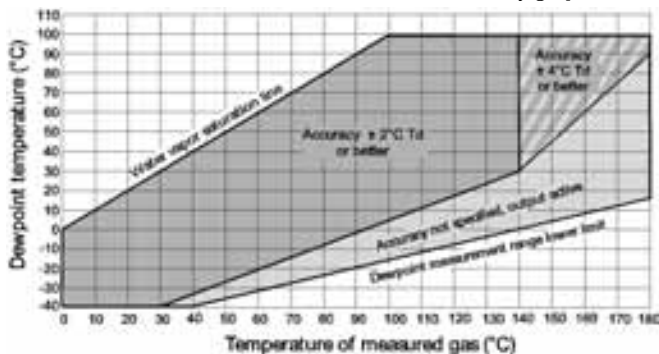

Dewpoint accuracy vs. measurement conditions

Response time 63 % [90 %] flow rate 1 l/min and 1 bar pressure	
from dry to wet	5s [10 s]
from wet to dry including auto-calibration	45s [5 min]

TEMPERATURE DMT345

Measurement range	0 ... +180 °C (+32 ... +356°F)
with sensor warming	upper range limited by humidity
	(at 80% RH warming is switched on and T reading not actual process Temperature)
Accuracy	±0.4 °C at 100 °C
Temperature sensor	Pt 100 IEC 751 1/3 class B

RELATIVE HUMIDITY DMT345

Measurement range	0 ... 100 % RH
with sensor warming	0 ... 80 % RH
Accuracy	
below 10 % RH	±10 % of reading
above 10 % RH	±1,5% RH + 1,5 % of reading

MIXING RATIO DMT345

Measurement range (typical)	0 ... 1000 g/kg (0 ... 7000 gr/lbs)
Accuracy (typical)	±12% of reading

Technical Data

Measured Variables DMT346

DEWPOINT DMT346

Sensor	Vaisala DRYCAP®180S
Measurement range	-25 ... +100 °C (-13 ... +212 °F) Td
Accuracy	±2 °C (±3.6 °F) Td See the accuracy graph below

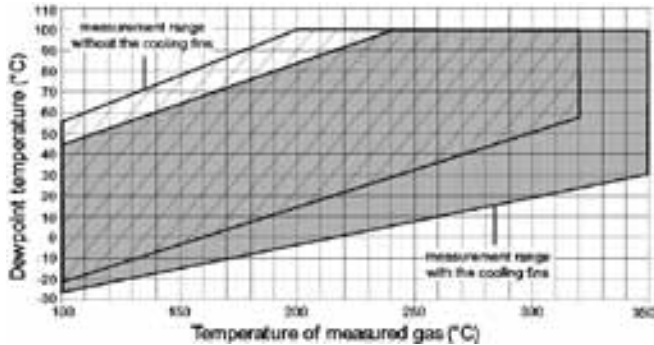

Dewpoint accuracy vs. measurement conditions

Response time 63 % [90 %] flow rate 1 l/min and 1 bar pressure	
from dry to wet	5s [10 s]
from wet to dry including auto-calibration	45s [5 min]

MIXING RATIO DMT346

Measurement range (typical)	0 ... 1000 g/kg (0 ... 7000 gr/lbs)
Accuracy (typical)	±12% of reading

Operating Environment, Both Models

Mechanical durability of probes	Up to +180 °C (+356 °F) for DMT345 Up to +350 °C (+662 °F) for DMT346
for transmitter body	-40 ... +60 °C (-40 ... +140 °F)
with display	0 ... +60 °C (32 ... +140 °F)
Storage temperature range	-55 ... +80 °C (-67 ... +176 °F)
Pressure range for probes	slight pressure difference (~ 200 mbar)
Measured gases	non corrosive gases
Complies with EMC standard EN61326-1, Electrical equipment for measurement, control and laboratory use - EMC requirements;	
Industrial environment.	

Inputs and Outputs, Both Models

Operating voltage	10 ... 35 VDC, 24 VAC
with optional power supply module	100 ... 240 VAC 50/60 Hz
Default start-up time	
initial reading after power-up	3 s
full operation after sensor Purge and Autocal	about 6 min
Power consumption @ 20 °C (U _{in} 24 VDC)	
U _{out} 2x0 ... 1V/0 ... 5V/0 ... 10V	max 25 mA
I _{out} 2x0 ... 20mA	max 60 mA
RS-232	max 25 mA
display and backlight	+ 20 mA
during sensor purge	+ 110 mA max
Analog outputs	(2 standard, 3rd optional)
current output	0 ... 20 mA, 4 ... 20 mA
voltage output	0 ... 1 V, 0 ... 5 V, 0 ... 10 V

Accuracy of analog outputs at 20 °C	± 0.05 % full scale
Temperature dependence of the analog outputs	± 0.005 %/°C full scale
External loads	
current outputs	R _L < 500 ohm
0 ... 1V output	R _L > 2 kohm
0 ... 5V and 0 ... 10V outputs	R _L > 10 kohm
Max wire size	0.5 mm ² (AWG 20) stranded wires recommended
Digital outputs	RS-232, RS-485 (optional)
Protocols	ASCII commands, MODBUS RTU
Service connection	RS-232, USB
Relay outputs 2+2 pcs (optional)	0.5 A, 250 VAC, SPDT
Ethernet interface (optional)	
Supported standards	10BASE-T, 100BASE-TX
Connector	8P8C (RJ45)
IPv4 address assignment	DHCP (automatic), static
Protocols	Telnet, MODBUS TCP/IP
WLAN interface (optional)	DHCP (automatic), static
Supported standards	802.11b
Antenna connector type	RP-SMA
IPv4 address assignment	DHCP (automatic), static
Protocols	Telnet, MODBUS TCP/IP
Security	WEP 64/128, WPA WPA2/802.11i

Authentication / Encryption (WLAN)

Open / no encryption	
Open / WEP	
WPA Pre shared key / TKIP	
WPA Pre shared key / CCMP (a.k.a. WPA2)	
Optional data logger with real-time clock	
Logged parameters	max. four with trend/min/max values
Logging interval	10 sec (fixed)
Max. logging period	4 years 5 months
Logged points	13,7 million points per parameter
Battery lifetime	min. 5 years
Display (optional)	LCD with backlight, graphic trend display
Display menu languages	English, French, Spanish, Chinese, German, Japanese, Russian, Swedish, Finnish

Mechanics, Both Models

Cable bushing	M20x1.5 For cable diameter 8 ... 11mm/0.31 ... 0.43"
Conduit fitting (optional)	1/2" NPT
User cable connector (optional)	M12 series 8-pin (male)
option 1	with plug (female) with 5 m /16.4 ft black cable
option 2	with plug (female) with screw terminals
USB-RJ45 Serial Connection Cable	part. no 219685
Probe cable diameter	5.5 mm
Probe cable length	2 m, 5 m or 10 m
Housing material	G-AISI 10 Mg (DIN 1725)
Housing classification	IP 65 (NEMA 4X)
Housing weight	1.2 kg

Technical Data

Dimensions

Dimensions in mm (inches)

DMT345 and DMT346 Transmitter housing

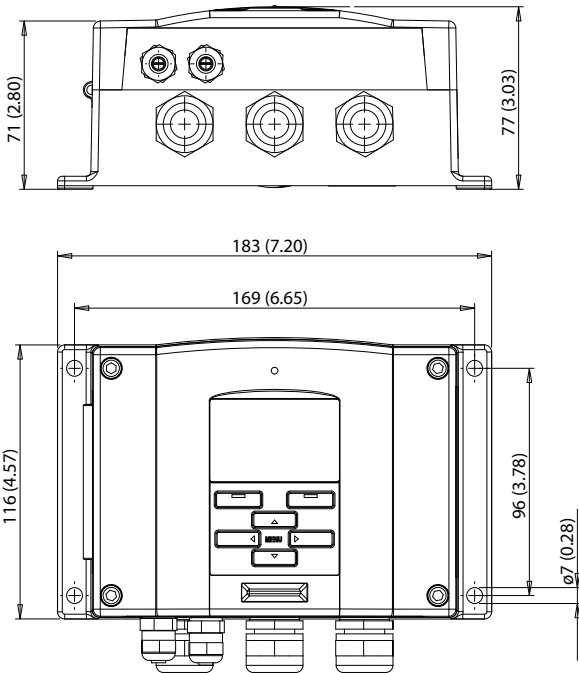

DMT345 probe and mounting flange

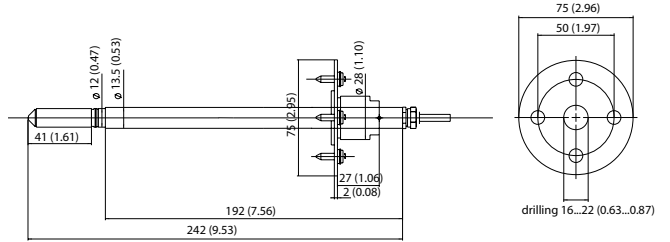

DMT346 Cooling set

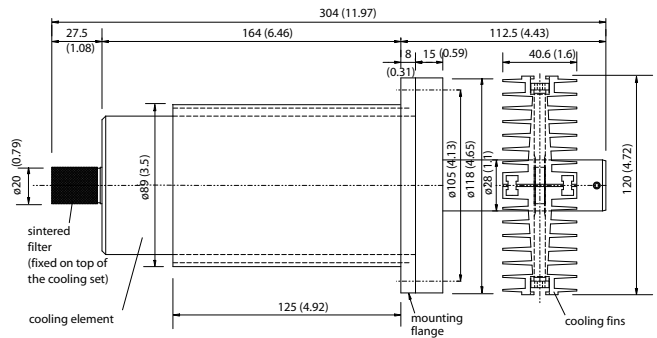

DMT346 Probe

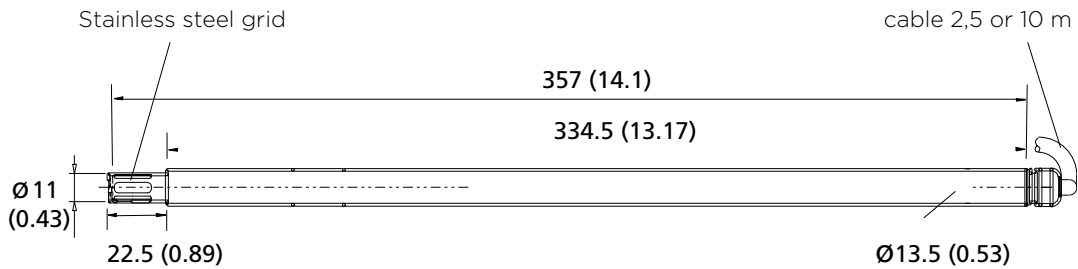

DRYCAP® is a registered trademark of Vaisala.



For more information, visit www.vaisala.com or contact us at sales@vaisala.com

Ref. B210723EN-D ©Vaisala 2011
 This material is subject to copyright protection, with all copyrights retained by Vaisala and its individual partners. All rights reserved. Any logos and/or product names are trademarks of Vaisala or its individual partners. The reproduction, transfer, distribution or storage of information contained in this brochure in any form without the prior written consent of Vaisala is strictly prohibited. All specifications — technical included — are subject to change without notice.



DMT242 Dewpoint Transmitter for OEM Applications



Due to its wide measurement range and high long-term stability, the DMT242 is an ideal choice for low dew point industrial applications such as compressed air dryers, plastic dryers and other OEM applications.

The Vaisala DRYCAP® Hand-Held Dewpoint Meter DM70 is ideal for confirming the performance of the DMT242 in the field.

Features/Benefits

- Ideal choice for industrial dryer applications
- Incorporates advanced Vaisala DRYCAP® Sensor and enhanced auto-calibration software
- Long-term stability in low dew points
- Fast response time
- Two sensor options cover dew point measurement range from -60 ... +60 °C (-76 ... +140 °F) with an accuracy of ± 2 °C (± 3.6 °F)
- Withstands condensation
- NIST traceable (certificate included)
- Compatible with Vaisala DRYCAP® Hand-Held Dewpoint Meter DM70

Vaisala DRYCAP®

The Vaisala DRYCAP® Dewpoint Transmitter DMT242 provides reliable and stable measurements for industrial dryer applications. It is designed for extreme conditions.

DMT242 incorporates the Vaisala DRYCAP® thin film polymer sensor and auto-calibration software.

The standard sensor choice for dry gases and desiccant dryers is DRYCAP® 180M and for more humid applications such as refrigeration dryers, a DRYCAP® 180S sensor.

Both the sensors are immune to particulate contamination, water condensation, oil vapor and most chemicals. Because the sensor withstands condensation, its performance is unmatched for low dew point applications that experience process water spikes, such as pipeline condensation during a system failure or start-up.

The auto-calibration software works on-line while the process is running. If the measurement accuracy is not confirmed, corrections are made automatically. The DMT242 adjusts the measurement, corrects dry-end drifts and continues to function. Calibration occurs quickly, and with corrections so minor, it will go unnoticed.

Compact, Rugged and Intelligent

Due to its compact size, DMT242 is quickly and easily installed in tight spaces.

Users can perform a field-check by using the Vaisala DRYCAP® Hand-Held Dewpoint Meter DM70. The transmitter can be sent to Vaisala Service for NIST traceable calibration. The recommended calibration interval is every two years.

Technical Data

Dew Point Temperature

Measurement range (typical)	-60 ... +60 °C (-76 ... +140 °F)
Analog output scalings	
Option A	-80 ... +20 °C (-112 ... +68 °F) T _d
Option B	-60 ... +60 °C (-76 ... +140 °F) T _d
Option X	free scaling

(when the dew point is below 0 °C (32 °F), the transmitter outputs frost point)

Accuracy with DRYCAP® 180M ± 2 °C (± 3.6 °F)
(see graph below)

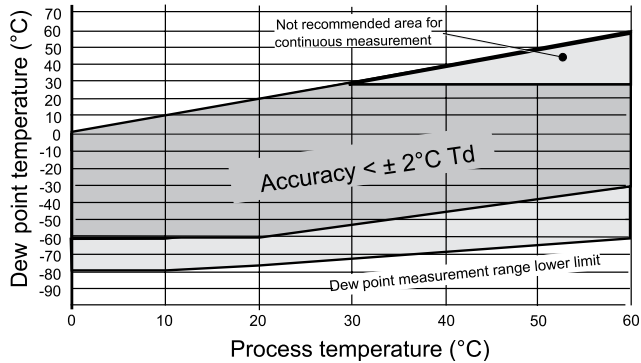

DEW POINT ACCURACY VS. MEASUREMENT CONDITIONS

Response time 63 % [90 %] at +20 °C gas temperature

Flow rate >1 l/min and 1 bar pressure

-60 → -20 °C Td (-76 → -4 °F Td) 5 s [10 s]

-20 → -60 °C Td (-4 → -76 °F Td) 45 s [10 min]

Accuracy with DRYCAP® 180S ± 2 °C (± 3.6 °F)
(see graph below)

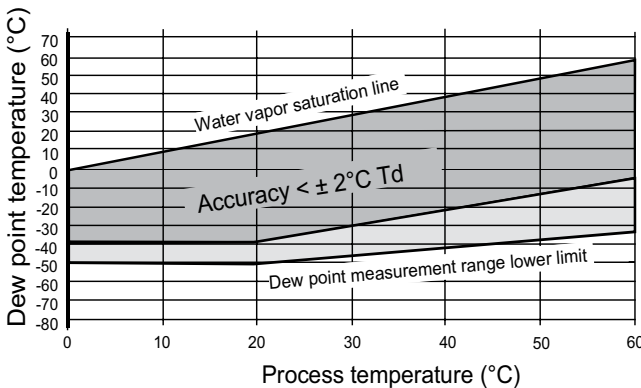

Operating Environment

Temperature	0 ... +60 °C (32 ... +140 °F)
higher temperature peaks	Short-term OK
Relative humidity	0 ... 100 %RH
Pressure	0 ... 20 bara (0 ... 290 psia)
Sample flow rate	no effect

Output

Analog output	4 ... 20 mA
Resolution for analog output	± 0.002 mA
Typical temperature dependence	0.0008 mA/ °C
Serial line for service use	RS232

General

Sensor	DRYCAP® 180M
Optimal sensor for refrigeration dryers	DRYCAP® 180S
Operating voltage	18 - 35 VDC, 20 - 28 VAC
Power consumption at 24 VDC	max. 220 mA
External load for analog output	max. 500 Ω
Optional connection cable with DMT242 connector	2 m or 10 m
Connector for supply voltage and signal output	
max. wire size	0.75 mm ²
max. cable diameter	6.5 mm /PG7
Service cable for serial interface RS232	product code DMT242RS

Probe material (wetted parts)	stainless steel (AISI 316L)
Sensor protection	stainless steel sintered filter (HM47280)
Mechanical connection	G $\frac{1}{2}$ " ISO228-1 thread with bonded seal ring (U-seal)
Electronics housing material	plastic (ABS/PC)
Housing classification	IP65 (NEMA4)
Storage temperature range	-40 ... +70 °C, (-40 ... +158 °F)

Complies with the EMC standard EN61326-1, Electrical equipment for measurement, control and laboratory use - EMC requirements; Industrial environment.



For more information, visit www.vaisala.com or contact us at sales@vaisala.com

Ref. B210765EN-C ©Vaisala 2011
This material is subject to copyright protection, with all copyrights retained by Vaisala and its individual partners. All rights reserved. Any logos and/or product names are trademarks of Vaisala or its individual partners. The reproduction, transfer, distribution or storage of information contained in this brochure in any form without the prior written consent of Vaisala is strictly prohibited. All specifications — technical included — are subject to change without notice.



DMT152 Dewpoint Transmitter for Low Dewpoint Measurement in OEM Applications



The small and powerful DMT152 measures dew point down to -80 °C.

Features/Benefits

- Compact
- Accurate
- Vaisala DRYCAP® technology with a polymer sensor
- Measures dew point down to -80 °C (-112 °F)
- Reduced maintenance costs due to long calibration interval
- Fast response time
- Withstands condensation
- NIST traceable
- Applications: compressed air, plastics drying, dry chambers, pure gases, and high-voltage circuit breakers

DMT152

The Vaisala DRYCAP® Dewpoint Transmitter DMT152 is designed for measuring low dewpoint in OEM applications, even down to -80°C . The excellent long-term stability and reliability of its performance is based on the latest DRYCAP® polymer sensor technology.

Low Maintenance

The DMT152 mechanics have been designed for harsh environments requiring protection against dust, dirt, and splashed water.

The DRYCAP® technology has a low maintenance need due to its excellent long-term stability and durability against condensation.

Applications

The DMT152 is an ideal choice for industrial applications where it is necessary to control very low humidity. Most typical areas of use are air and plastics dryers, dry chambers, pure gases, and high-voltage circuit breakers.

The DMT152 measures accurately and reliably also in the challenging combination of low humidity and hot air, which is typical in plastics drying.

Technical Data

Measured Variables

DEW POINT TEMPERATURE

Measurement range	-80 ... -10 °C (-112 ... +14 °F) T _d
Accuracy	±2 °C (3.6 °F) T _d
Non-calibrated range	-100 ... +20 °C (-148 ... +68 °F) T _d
Analog output scalings	
option 1	-80 ... +20 °C (-112 ... +68 °F) T _d
option 2	-100 ... 0 °C (-148 ... +32 °F) T _d
option 3	user-specified output scaling
when dew point is below 0 °C (32 °F) the transmitter outputs	
frost point	

Accuracy over temperature range

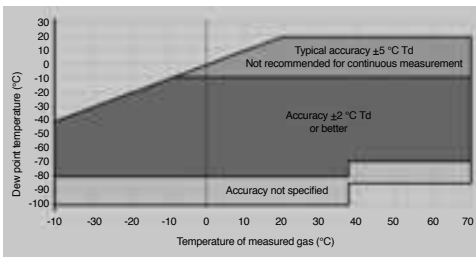

Response time 63 % [90 %] at a gas temperature of +20 °C (+68 °F) and pressure of 1 bar

-10 ... -80 °C T _d	0.5 min [7.5 min]
-80 ... -10 °C T _d	2 s [5 s]

PPM VOLUME CONCENTRATION

Measurement range (typical)	0 ... 500 ppm
Accuracy at +20 °C (+68 °F), 1013 mbar	±(0.2 ppm + 20 % of reading)

Operating Environment

Temperature	-40 ... +70 °C (-40 ... +158 °F)
Relative humidity	0 ... 100 %RH (up to +20 °C/68 °F)
Pressure	0 ... 50 bar (725 psia)
Measured gases	non-corrosive gases
Sample flow rate	no effect on measurement accuracy

Outputs

Two analog outputs (scalable)	4 ... 20 mA, 0 ... 20 mA (3 wire) 0 ... 5 V, 0 ... 10 V
Accuracy of analog outputs	±0.01 V / ±0.01 mA
Digital output	RS485 (2-wire)
Alarm-level indication by analog signal	user selectable
Purge information	5 V, 10 V, 20 mA or LED

General

Sensor	Vaisala DRYCAP® 180U
	Thin-film capacitive polymer sensor
Recommended calibration interval	2 years
Operating voltage with	
RS485 output	11* ... 28 VDC
voltage output	15* ... 28 VDC
current output	21 ... 28 VDC
*For extended temp. down to -40 °C (-40 °F) or pressure up to 50 bar (725 psia), the supply voltage is 21 ... 28 VDC.	
Supply current	
normal measurement	20 mA + load current
during self-diagnostics	max. 220 mA pulsed
Supply voltage fluctuation	max. 0.3 V
External load for	
voltage output	min. 10 kOhm
current output	max. 500 Ohm
Housing material (wetted parts)	AISI316L
Stainless steel mesh filter	AISI303, filter grade 18 µm
Mechanical connections	ISO G½", NPT ½", UNF 3/4"- 16"
Housing classification	IP65 (NEMA 4)
Storage temperature range	-40 ... +80 °C (-40 ... +176 °F)
Weight (ISO G½")	190 g (6.70 oz)
Complies with EMC standard EN61326-1, Electrical equipment for measurement control and laboratory use - EMC requirements;	
Industrial environment	

Accessories

Connection cable for MI70 hand-held indicator	219980
USB cable for pc connection	219690
Sampling cells (available for ISO G½")	
basic sampling cell	DMT242SC
with Swagelok 1/4" male connectors	DMT242SC2
with a quick connector and leak screw	DSC74
two-pressure sampling cell	DSC74B
NW40 flange	225220SP

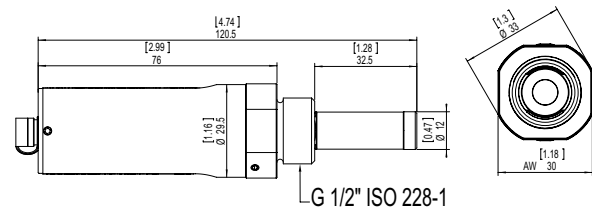

For more information, visit www.vaisala.com or contact us at sales@vaisala.com

Ref. B210750EN-C ©Vaisala 2010
This material is subject to copyright protection, with all copyrights retained by Vaisala and its individual partners. All rights reserved. Any logos and/or product names are trademarks of Vaisala or its individual partners. The reproduction, transfer, distribution or storage of information contained in this brochure in any form without the prior written consent of Vaisala is strictly prohibited. All specifications — technical included — are subject to change without notice.



DMT142 Miniature Dewpoint Transmitter for OEM Applications



The Vaisala DRYCAP® Dewpoint Transmitter DMT142 is an ideal choice for small compressed air dryers, plastic dryers and other OEM applications.

Vaisala DRYCAP®

The Vaisala DRYCAP® Dewpoint Transmitter DMT142 is a miniature dew point measurement instrument. The transmitter can be installed directly into pressurized systems at 50 bar (725 psia) maximum pressure. The long-term high performance is achieved with Vaisala DRYCAP® technology.

The sensor fully withstands getting wet, and therefore, the transmitter performs exceptionally well in applications that occasionally experience process water spikes, such as pipeline condensation during a system failure or start-up. The sensor is also immune to particulate contamination, oil vapor and most chemicals, and is insensitive to the flow rate.

Long Calibration Interval

The calibration interval of the DMT142 is two years. Additionally, the Vaisala DRYCAP® Hand-Held Dewpoint Meter DM70 can be used to confirm the performance of the DMT142 without disconnecting the transmitter. For any adjustment needs, the transmitter can be sent to Vaisala Service.

The auto-calibration software works on-line while the process is running. If the measurement accuracy is not confirmed, corrections are made automatically.

Features/Benefits

- Miniature size dew point transmitter for e.g. small industrial dryer applications
- Vaisala DRYCAP® technology with auto-calibration
- Calibration interval of two years
- Dew point measurement range -60 ... +60 °C (-76 ... +140 °F) with an accuracy ±3 °C (±5.4°F)
- Withstands condensation
- Fast response time
- Compatible with Vaisala DRYCAP® Hand-Held Dewpoint Meter DM70
- NIST traceable (certificate included)

Easy Installation

The DMT142 has a variety of features to choose from, including different output and installation options. Due to its small size and light weight, the DMT142 is quickly and easily installed in tight spaces or in small-size pipelines.

Technical Data

Measured Variables

DEW POINT TEMPERATURE	
Measurement range(typical)	
Standard version	-40 ... +60 °C (-40 ... +140 °F) T _d
Extended version	-60 ... +60 °C (-76 ... +140 °F) T _d
SF ₆ version	-50 ... +60 °C (-58 ... +140 °F) T _d
Analog output scalings	
option 1	-80 ... +20 °C (-112 ... +68 °F) T _d
option 2	-60 ... +40 °C (-76 ... +104 °F) T _d
option 3	free scaling
Accuracy	±3 °C (±5.4 F) T _d (see graph below)
(when the dew point is below 0 °C (32 °F), the transmitter outputs frostpoint)	

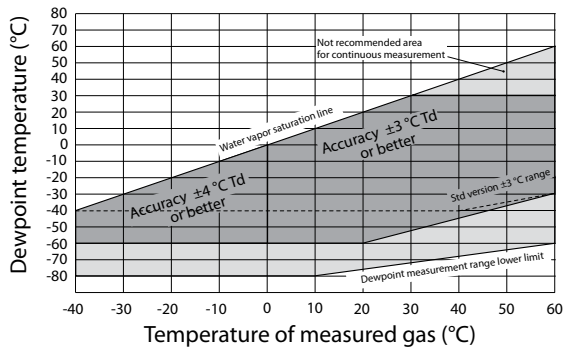

Dewpoint accuracy range for the extended version. Standard version with dotted line.

DEW POINT ACCURACY VS. MEASUREMENT CONDITIONS
Dew point accuracy range for the extended version. Standard version with dotted line.

Response time 63% [90%] at +20 °C gas temperature and 1 bar pressure

-60 > -20 °C T_d (-76 > -4 °F T_d) 5 s [10 s]
-20 > -60 °C T_d (-4 > -76 °F T_d) 45 s [10 min]

PPM VOLUME CONCENTRATION

Measurement range 70 ... 200 000 ppm

Accuracy at +20 °C (+68 °F), 1013 mbar 7.3 ppm + 9.2% of reading

Operating Environment

Temperature *) -40 ... +60 °C (-40 ... +140 °F)

Relative humidity 0 ... 100 %RH

Pressure *) 0 ... 50 bar_a (725 psia)

Sample flow rate no effect for measurement accuracy

*) For extended temperature down to -40 °C (-40 °F) or pressure up to 50 bar_a (725 psia) the supply voltage must be 24 ... 28 VDC.

Outputs

Analog output (scalable) 4 ... 20 mA (3-wire), 0 ... 1 V/5 V

Resolution for current output 0.002 mA

Resolution for voltage output 0.3 mV

Typical temperature dependence 0.005% of span / °C

Connector 4-pin M8 (IEC 60947-5-2)

connection cable with snap-on or thread locking available

RS232 serial line for service use with DMT142RS cable

General

Sensor Vaisala DRYCAP® 180D

Measured gases non-corrosive gases
(SF₆ gas with special model)

Recommended calibration interval to confirm the specified accuracy	2 years
Operating voltage with voltage output	12 ... 28 VDC
Operating voltage with current output	18 ... 28 VDC
Supply current	
normal measurement	10 mA + load current
during self-diagnostics	max. 220 mA pulsed
Load for current output	max. 500 ohm
Load for voltage output	min. 10 kohm
Housing material	stainless steel body (AISI316L) plastic cap(ABS/PC)
Sensor protection	stainless steel sintered filter
Mechanical connection	G1/2" ISO 228-1 thread with bonded seal ring (U-seal)
Housing classification	IP64 (NEMA 3S)
Storage temperature range	-40 ... +80 °C (-40 ... +176 °F)
Weight	118 g (4.16 oz)
Complies with EMC standard EN61326-1, Electrical equipment for measurement, control and laboratory use - EMC requirements;	
Industrial environment.	

Accessories

Connection cable for DM70	211917ZZ
Service cable for serial line	DMT142RS
Sampling cells	
basic sampling cell	DMT242SC
with Swagelok 1/4" male connectors	DMT242SC2
with quick connector and leak screw	DSC74
two-pressure sampling cell	DSC74B
cooling/venting coil	DMCOIL
See DM70 / Portable Sampling Systems and Sampling Cells for further information about sampling cells available	
Loop powered external display	226476

Dimensions

in mm

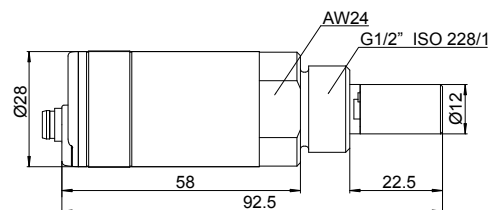

VAISALA

For more information, visit www.vaisala.com or contact us at sales@vaisala.com

Ref. B210375EN-C ©Vaisala 2011

This material is subject to copyright protection, with all copyrights retained by Vaisala and its individual partners. All rights reserved. Any logos and/or product names are trademarks of Vaisala or its individual partners. The reproduction, transfer, distribution or storage of information contained in this brochure in any form without the prior written consent of Vaisala is strictly prohibited. All specifications — technical included — are subject to change without notice.



DMT132 Dewpoint Transmitter for Refrigerant Dryers



Features / Benefits

- Affordable dew point transmitter for refrigerant dryers
- High accuracy $\pm 1^{\circ}\text{C}$ ($\pm 1.8^{\circ}\text{F}$) in the measurement range of refrigerant dryers
- Excellent long-term stability - resistant to compressor oil and most other chemicals thanks to HUMICAP[®] technology
- Low power requirements, 10 ... 28 VDC
- Easy to verify functionality with compatible hand-held meters DM70 or HM70
- Optional LED warning light

The optional LED warning light tells the user when the defined dew point limit has been exceeded.

The Vaisala HUMICAP[®] Dewpoint Transmitter DMT132 is an affordable dew point measurement instrument designed to verify the functionality of refrigerant dryers. It is especially well suited for OEM dryer manufacturers.

Direct Measurement Cuts Costs

Direct outlet air dew point measurement provides accurate information about dryer functionality and is more reliable than the traditional method of measuring refrigerator temperature only. Knowledge of the real dew point ensures high quality compressed air at all times and enables customers to optimize dryer capacity. This helps to prevent investment in redundant dryer capacity and avoid unnecessary maintenance and costly malfunctions.

High Accuracy and Long-Term Stability

The DMT132 provides optimal performance in the operating range of refrigerant dryers. In the measurement range of $-3 \dots 20^{\circ}\text{C}$ ($+26.6 \dots +68^{\circ}\text{F}$), where the refrigerator dryers typically operate, the Td accuracy is $\pm 1^{\circ}\text{C}$ ($\pm 1.8^{\circ}\text{F}$). The instrument incorporates the proven Vaisala HUMICAP[®] sensor, which is resistant to compressor oil and most other chemicals, thereby providing excellent long-term stability.

Quick Installation and Easy Field Checking

It takes just a few minutes to install the DMT132 directly into a dryer or compressed air line through a G1/2" ISO thread. Vaisala sampling cells can also be used. The loop-powered electronics mean that wiring is easy and power requirements are low. The

DMT132 operating voltages can be as low as 10 VDC.

Verifying the performance of the DMT132 is easy with the compatible Vaisala hand-held DM70 or HM70 meters. The user can perform possible adjustments with the Vaisala HMK15 Humidity Calibrator.



Demand for dew point sensors to verify refrigerant dryers is increasing. Direct dew point measurement enables energy savings and improved efficiency.

Technical Data

Performance

DEW POINT

Measurement range	-20 ... +50 °C (-4 ... +122 °F) Td
Accuracy (at +20 °C (+68 °F))	±1 °C for -3...20 °C (+26.6 ... +68 °F) Td ±2 °C for -15...-3 °C (+5 ... +26.6 °F) Td

* when dew point is below 0 °C (+32 °F), the transmitter outputs frostpoint
see accuracy graph below

Response time at 20 °C (+68 °F) gas temperature and 1 bar pressure	
-14 → +3 °C (+7 → +37 °F) Td	17 s (63%)
	40 s (90%)
+3 → -14 °C (+37 → +7 °F) Td	33 s (63%)
	85 s (90%)

CALCULATED VARIABLES

Dew point converted to atmospheric pressure	Tdf atm
---	---------

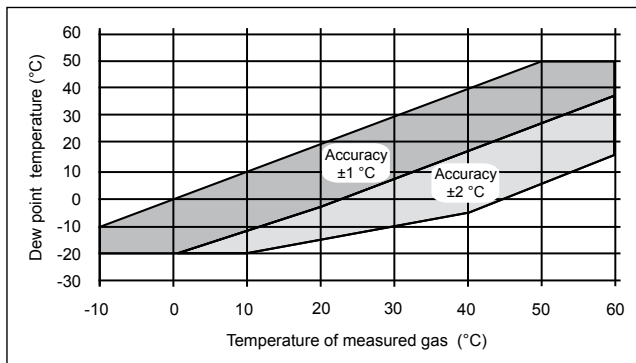

Operating Environment

Operating temperature	-10 ... +60 °C (+14 ... +140 °F)
Operating pressure	0 ... 20 bar
Relative humidity	0 ... 100 %RH
Sample flow rate	no effect on measurement accuracy
Measured gases	non-corrosive gases

Outputs

Analog output (scalable)	4...20 mA, 2-wire
Resolution for current output	0.002 mA
Accuracy of analog outputs at +20 °C	±0.05% full scale
Typical temperature dependence	±0.005% of full scale/ °C
Connector	4-pin M8 (IEC 60947-5-2)
LED indication available for defined dew point limit/ error state indication	
RS485 serial line for service use	

General

Sensor	Vaisala HUMICAP®180R
Recommended calibration interval (in refrigerant dryer application)	2 years
Mechanical connection	G 1/2" ISO
Operating voltage	10 ... 28 VDC
External load	max 100 ohm for supply voltages <20 VDC max 500 ohm for supply voltages 20...28 VDC
Weight	65 g (2.3 oz)
Housing material	PPS + 40% GF
Housing classification	IP65 (NEMA 4)
Storage temperature range	-40 ... +80 °C (-40 ... +176 °F)
Start-up time	3 s
Complies with EMC standard EN61326-1, Electrical equipment for measurement control and laboratory use - EMC requirements; Industrial environment	

Options and Accessories

Tube filter	230602
Special cover set for HMK15 (calibrator fitting DMT132 and HMP60)	230914
NPT Adapter	210662SP
Sample cells	DMT242SC, DMT242SC2, DSC74, DSC74B, DSC74C, DMCOIL
Duct installation flange	DM240FA
Cables (several lengths available)	HMP50Z032, HMP50Z300SP, HMP50Z500SP, HMP50Z1000SP
Loop powered external display	226476
USB Service cable	219690
Connection cable to DM70/HM70	219980
LED plug	230388
ISO" 1/2 plug	218773
NPT1/2" plug	222507
Sealing ring set (3 pcs U-seal)	221525SP

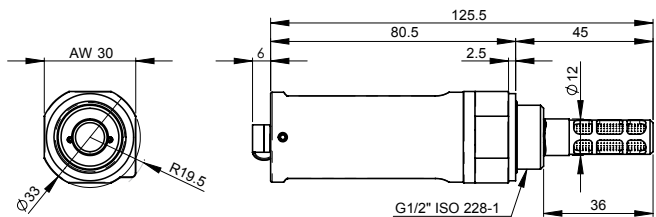

For more information, visit www.vaisala.com or contact us at sales@vaisala.com

Ref. B211105EN-B ©Vaisala 2011

This material is subject to copyright protection, with all copyrights retained by Vaisala and its individual partners. All rights reserved. Any logos and/or product names are trademarks of Vaisala or its individual partners. The reproduction, transfer, distribution or storage of information contained in this brochure in any form without the prior written consent of Vaisala is strictly prohibited. All specifications — technical included — are subject to change without notice.



DM70 Hand-Held Dewpoint Meter for Spot-Checking Applications



Features/Benefits

- Designed for industrial spot-checking and field calibration
- Three models: accurate measurement ranges from -60 to +60 °C (-76 ... +140 °F)
- Vaisala DRYCAP® Sensor with patented autocalibration function
- Low maintenance need due to superior long-term stability
- Sensor withstands condensation
- Fast response, enhanced by Sensor Purge option
- Easy-to-use user interface
- Data can be logged and transferred to a PC via MI70 Link software
- Compact, small and light
- NIST traceable (certificate included)

The Vaisala DRYCAP® Hand-Held Dewpoint Meter DM70 measures dew point temperature accurately over a wide measurement range. The probe may be inserted directly into pressurized processes, and it responds rapidly from ambient to process conditions. The sensor withstands condensation and fully recovers from getting wet.

Three probe models, all with auto-calibration, are available. The A and B models are both general purpose probes. The C model is specifically developed for SF₆ gas. The B and C probe models have an additional Sensor Purge feature that heats and dries the sensor, making the

The Vaisala DRYCAP® Hand-Held Dewpoint Meter DM70 offers accurate and fast measurement for industrial dew point applications, such as compressed air, metal treatment and plastics drying.

response from ambient to dry conditions exceptionally fast.

The DM70 is fitted with the Vaisala DRYCAP® Sensor. The sensor provides reliable, stable and high-performance dew point measurement. Autocalibration detects on-line possible measurement inaccuracies and automatically corrects dry-end drift in the calibration curve.

The DM70 has a versatile and easy-to-use, menu-based user interface, a clear graphical LCD display, and data-logging capability. It can also be used as a tool for reading the output of fixed Vaisala dew point transmitters, like the DMT242, DMT132, DMT142, DMT152 and DMT340.

The DM70 displays one to three parameters at a time, either numerically or graphically. Several humidity units can be selected. In addition, the DM70 includes conversion from gas pressure dew point to ambient pressure dew point. An analog output is also available.

The DM70 meter is suitable for direct process dew point measurement in a wide temperature and pressure range. For more demanding applications, the DM70 can be used with the Vaisala sampling cell adapters, or with the Vaisala DRYCAP® Sampling System DSS70A.

Technical Data

Measured Variables, DMP74A Probe

DEW POINT

Measurement range (typical) -50 ... +60 °C (-58 ... +140 °F)
 Accuracy (A probe) -40...+60 °C ± 2 °C (± 3.6 °F)
 (see graph)

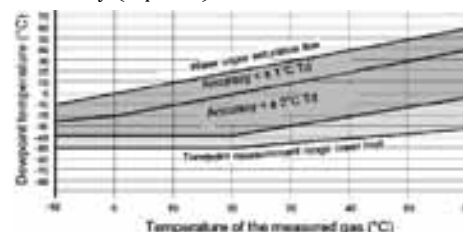

Dew point accuracy vs. measurement conditions

Response time

flow rate 0.2 m/s, 1 bar pressure, +20 °C (+68 °F) 63% [90%]
 0 → -40 °C T_d (32 → -40 °F T_d) 20 s [120 s]
 -40 → 0 °C T_d (-40 → 32 °F T_d) 10 s [20 s]

Dew point sensor

Vaisala DRYCAP® 180S

Technical Data

TEMPERATURE	
Measurement range	-10 ... +60 °C (+14 ... +140 °F)
Accuracy at +20 °C (+68 °F)	±0.2 °C (±0.36 °F)
Typical temperature dependence of electronics	±0.005 °C/°C (±0.005 °F/°F)
Temperature sensor	Pt100 IEC751 1/3 class B
OTHER VARIABLES AVAILABLE	
Dew point converted to atmospheric pressure, ppm volume and ppm weight concentration, absolute humidity, mixing ratio, relative humidity	

Measured Variables, DMP74B and DMP74C (for SF6 gas) Probes

DEW POINT	
Measurement range (typical)	-70 ... +30 °C (-94 ... +86 °F)
Accuracy (B and C probe)	-60...+20 °C ±2 °C (±3.6 °F) (see graph)

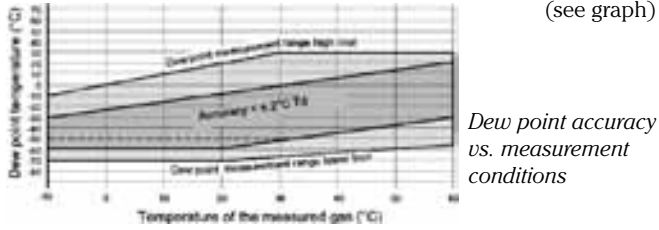

Dotted line:
For DMP74C the ±2 °C accuracy range is limited to -50 °C T_d when used in SF6 gas.

Response time	
flow rate 0.2 m/s, 1 bar pressure, +20 °C (+68 °F)	63% [90%]
0 → -60 °C T _d (32 → -76 °F T _d)	50 s [340 s]
-60 → 0 °C T _d (-76 → 32 °F T _d)	10 s [20 s]
Dew point sensor	Vaisala DRYCAP® 180M

TEMPERATURE	
Measurement range	-10 ... +60 °C (+14 ... +140 °F)
Accuracy at +20 °C (+68 °F)	±0.2 °C (±0.36 °F)
Typical temperature dependence of electronics	±0.005 °C/°C (±0.005 °F/°F)
Temperature sensor	Pt100 IEC751 1/3 class B
OTHER VARIABLES AVAILABLE	
Dew point converted to atmospheric pressure, ppm volume and ppm weight concentration	

All Probe Models

Operating temperature	-10 ... +60 °C (+14 ... +140 °F)
Operating pressure	
DMP74A, DMP74B	0 ... 20 bara (0 ... 290 psia)
DMP74C	0 ... 10 bara (0 ... 150 psia)

Sample flow rate	no effect for measurement accuracy
Measured gases	non-corrosive gases
Probe material (wetted parts)	Stainless steel (AISI 316L)
Sensor protection	Sintered filter (AISI 316L) partno: HM47280
Mechanical connection	G1/2" ISO228-1 thread with bonded seal ring (U-seal)
Housing classification	IP65 (NEMA 4)
Weight	350 g

MI70 Indicator, General

Menu languages	English, Chinese, Spanish, Russian, French, Japanese, German, Swedish, Finnish,
Display	LCD with backlight Graphic trend display of any parameter Character height up to 16 mm
Max. no of probes	2
Power supply	Rechargeable NiMH battery pack with AC-adaptor or 4xAAA size alkalines, type IEC LR6
Analog output	0...1 VDC
Output resolution	0.6 mV
PC interface	MI70 Link software with USB or serial port cable
Datalogging capacity	2700 points
Alarm	Audible alarm function
Operating temperature range	-10...+40 °C (+14...+104 °F)
Storage temperature range	-40 ... +70 °C (-40 ... +158 °F)
Operating humidity range	0 ... 100 % RH, non-condensing
Housing classification	IP54
Housing materials	ABS/PC blend
Weight	400 g
Battery operation time with DMP74 probe	
continuous use	48 h typical at +20 °C (+68 °F)
data logging use	up to a month, depending on logging interval
Electromagnetic compatibility	EN 61326-1, Generic Environment

Accessories

Connection cables for fixed Vaisala dew point transmitters	
for DMT242 transmitter	27160ZZ
for DMT340 series	211339
for DMT152 and DMT132 transmitters	219980
for DMT142 transmitter	211917ZZ
MI70 Link software with USB cable	219687
MI70 Link software with serial port cable	MI70LINK
Analog output cable	27168ZZ
10 m (32.81 ft) extension cable for probe	213107SP
Portable Sampling System	DSS70A
(see separate data sheet)	



For more information, visit www.vaisala.com or contact us at sales@vaisala.com

Ref. B010162EN-C ©Vaisala 2011
This material is subject to copyright protection, with all copyrights retained by Vaisala and its individual partners. All rights reserved. Any logos and/or product names are trademarks of Vaisala or its individual partners. The reproduction, transfer, distribution or storage of information contained in this brochure in any form without the prior written consent of Vaisala is strictly prohibited. All specifications — technical included — are subject to change without notice.



DSS70A Portable Sampling System and Sampling Cells for DM70



The DSS70A provides a compact solution for field checking dew point where direct measurement is difficult. Typical applications for the sampling system are metal treatment and plastics drying processes.

DSS70A Portable Sampling System

The DSS70A is designed to provide dewpoint sampling flexibility for the DM70 hand-held dew point meter. For processes at atmospheric pressure, a battery powered pump is used to extract a gas sample. For pressurized processes up to 20 bar, the sample is measured at process pressure and then reduced to atmospheric pressure for venting or re-direction, bypassing the pump. In all cases, the sample gas passes through a filter to remove particulate contamination before measurement. Flow through the system is controlled and monitored with a needle valve and flow meter.

The DSS70A is easily connected to an appropriate sample point with tubing (typically 1/4" or 6 mm). The measured dewpoint must be below ambient temperature to avoid condensation in the system. Gas temperatures higher than +40 °C

(+104 °F) should be cooled with a short PTFE (included in the DSS70A system) or stainless steel tube prior to entering the DSS70A. DSS70A is an accessory for DM70 Dewpoint Hand-held Meter.

Sampling Cells for Pressurized Processes

The DM70 can easily be connected to pressurized processes. In addition to direct pipeline installation, a variety of sampling cell options are available for gas sampling.

The DSC74 sampling cell is the recommended choice. It has a variety of connection adapters that allow several different ways of installation. The quick connector with a leak screw allows a very fast connection for compressed air lines. Additionally, two thread adapters are available for the inlet port.

The DSC74B is a two-pressure sampling cell, which enables measurements in both process and

ambient pressure. This sampling cell is especially suitable for dewpoint measurements in SF₆ gas with the DMP74C probe.

The DMT242SC is a basic sampling cell. The DMT242SC2 is a sampling cell supplied with welded Swagelok connectors for sampling in a 1/4" pipeline.



The sampling cells (from the left) DMT242SC2, DMT242SC and DSC74 can be used to connect the DM70 to sample gas flow. The DSC74B (right) is a two-pressure sampling cell that can be used for measurements in either pressurized or ambient pressure. The cooling/venting coil is included in the DSC74C sample cell, but is an option for all sampling cells.

Technical Data

DSS70A Sampling System and DSC74B/C Sampling Cells

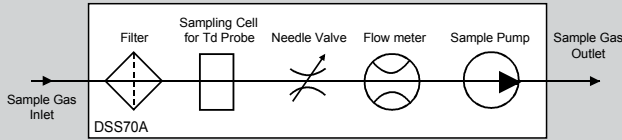

The DSS70A sampling system includes a filter to clean the dirty sample gas and a needle valve to control the sample flow rate with the flow meter. A sample pump is used to generate a sample flow from processes at ambient pressure.

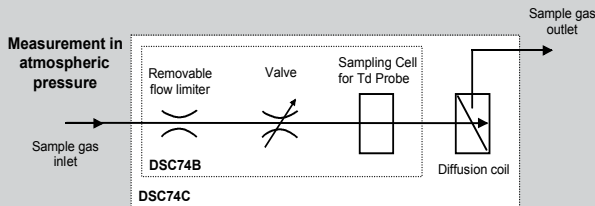
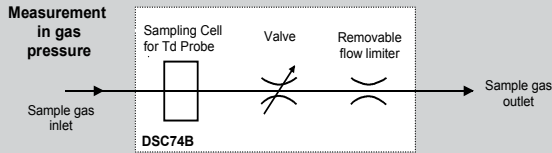

The DSC74B sampling cell enables the measurement of the sampled gas either in gas pressure up to 10 bar or in atmospheric pressure depending on the gas inlet and outlet. The DSC74C is like the DSC74B but with an additional coil to avoid back diffusion, the effect of surrounding moisture, in dewpoint measurements in atmospheric pressure.

Sampling Cells Technical Data

DSC74	sampling cell for pressurized gases
pressure limit	1 MPa (10 barg, 145 psig)
DSC74B	two pressure sampling cell
pressure limit	1 MPa (10 barg, 145 psig)
DSC74C	DSC74B with DMCOIL cooling/venting coil

DMCOIL	cooling/venting coil
DMT242SC	sampling cell
pressure limit	10 MPa (100 barg, 1450 psig)
DMT242SC2	sampling cell with Swagelok connectors
pressure limit	4 MPa (40 barg, 580 psig)
Material for all sampling cells	stainless steel AISI316

DSS70A Sampling System Operating Conditions

Operating gases	air, N2 and other non-toxic, inert gases
Sampled gas dew point	below Tamb
Inlet/outlet connection	1/4" Swagelok
Operating temperature	
ambient temperature	0 ... +40 °C (32 ... +104 °F)
process gas temperature	
with PTFE tube at +20 °C (+68 °F)	max. +200 °C (+392 °F)
with stainless steel tube	specification according to stainless steel tube specification
(included in the DSS70A)	
maximum gas temperature at inlet	+40 °C (+104 °F)
Operating pressure	
with pump	0.6 ... 1.2 bara (8.7 ... 17.4 psia)
pump disconnected	0 ... 20 bara (0 ... 290 psia)

General

Battery operation time for pump	8 h continuous use
	battery can be recharged using DM70 charger
Filter	7 mm inline filter cartridge 1/4" Swagelok SS-4F-7 (spare part order no. 210801)
Materials	
wetted parts	Stainless steel
carrying case	ABS plastic
Case size (W x D x H)	430 x 330 x 100 mm
Weight	5.5 kg (12 lbs)

Electromagnetic Compatibility

EN61326-1, Generic Environment.

DPT146 Dewpoint and Pressure Transmitter for Compressed Air



The DPT146 measures both dew point and process pressure. Monitoring compressed air is simpler and quicker, helping you to make more informed decisions.

The Vaisala Dewpoint and Pressure Transmitter DPT146 for Compressed Air makes monitoring compressed air simple and convenient. The DPT146 measures both dew point and process pressure simultaneously, and is the ideal choice for anyone using or monitoring compressed air.

Make More Informed Decisions

For the first time, dew point data – whether calculated to atmospheric pressure or providing ppm – is constantly pressure compensated online and in real-time so there is no ambiguity in the information. Decision making and corrective actions can now be based on more reliable and accurate data. Regulative requirements, for example for medical gas, can also be fulfilled more easily and quickly.

Simple and Efficient Installation

One transmitter providing two of the most important compressed

air measurements means reduced installation costs and a much easier setup – with only one instrument needing connection and wiring.

A Unique Combination of Two World-Class Sensors

The DPT146 combines the knowledge of more than 20 years of sensor-technology development. Proven measurements from the DRYCAP® sensor for dew point and the BAROCAP® sensor for pressure are now combined into one easy-to-use transmitter.

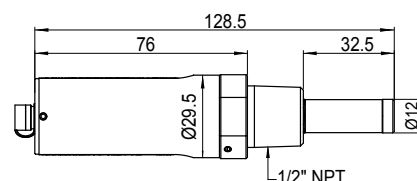
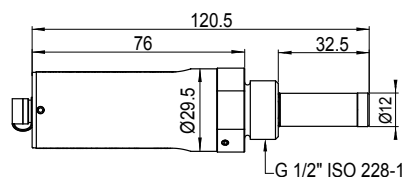

Features/Benefits

- The first transmitter that monitors both dew point and process pressure
- A simple and convenient transmitter for monitoring of compressed air
- Highly accurate humidity information thanks to online pressure-compensated dew point data
- Proven sensor technology
- Compatible with the Vaisala Hand-Held DM70 for easy spot checking, local display and data logging
- Pressure: 1 ... 10 bar
- Dew point: -60 ... +30 °C (-76 ... +86 °F) Tdf with accuracy of ±2°C (±3.6 °F)

Convenience with Proven Performance

Well-developed technology brings both proven results and convenience. Spot-checking and verification of dew point is easy thanks to full compatibility with the Vaisala DRYCAP® Hand-Held Dewpoint Meter DM70. The DM70 can also be used as a local display and data logger for monitoring all measured parameters. Additionally, also temperature measurement is available when the RS485 serial line is in use.

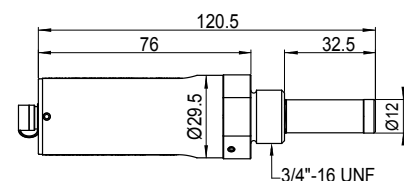
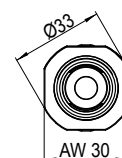

Technical Data

Measured Parameters

Dew point	-60 ... +30 °C (-76 ... +86 °F)
Pressure, absolute	1 ... 10 bar (14.5 ... 145 psi)
Temperature (available if output RS-485 only selected)	-40 ... +80 °C (-40 ... +176 °F)

Calculated Parameters

ppm moisture, by volume	1 ... 40 000 ppm
Dew point, converted to atmospheric pressure	-75 ... +30 °C (-103 ... +86 °F)

Performance

Dew point accuracy	±2 °C (±3.6 °F)
Pressure accuracy at 23 °C (73.4 °F)	±0.4 %FS
Pressure temperature dependence	±0.1 %FS/10 °C (18 °F)
Temperature accuracy	
0 ... 40 °C (+32 ... +104 °F)	±0.5 °C (± 0.9 °F)
-40...80 °C (-40 ... +176 °F)	±1 °C (± 1.8 °F)
PPM accuracy (7 bar)	±(14 ppm + 12% of reading)
Sensor response time:	
Pressure response time	< 1 s
Dew point response time 63% [90%] at 20°C and 1 bar	
-50 -> -10 °C Tdf	5 s [10 s]
-10 -> -50 °C Tdf	10 s [2.5 min]

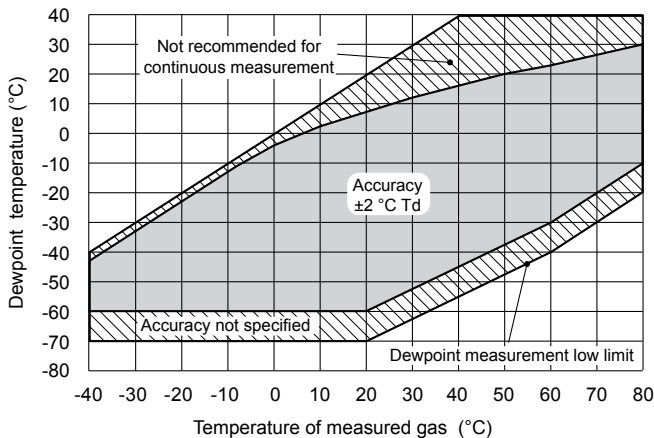

DPT146 Dewpoint Measurement Accuracy

Operating Environment

Operating temperature of electronics	-40 ... +60 °C (-40 ... +140 °F)
Operating Pressure	0 ... 50 bar (0...725 psi)

Relative humidity	0...100 %
Measured gases	Air/ non-corrosive gases
Sample flow rate	no effect on measurement accuracy

Outputs

Analog Outputs (2 channels)	
current output	0 ... 20 mA, 4 ... 20 mA
voltage output	0 ... 5V, 0 ... 10V
Accuracy of analog outputs	± 0.01 V / ± 0.01 mA
Digital output	RS-485, non-isolated, Vaisala protocol
Connector	4-pin M8

General

Sensor	Vaisala MPS1 multiparameter sensor
Operating voltage	21 ... 28 VDC, current output 20 ... 28 VDC, voltage output and/or use in cold temperatures (-40 ... -20 °C (-40 ... -4 °F)) 15 ... 28 VDC, RS485 only
Supply current	
during normal measurement	20 mA + load current
during self-diagnostics	300 mA + load current
External load for	
current output	max. 500 Ohm
voltage output	min. 10 kOhm
Housing material	AISI316L
Housing classification	IP65 (NEMA4)
Sensor protection	Mesh filter AISI303, grade 18 µm
Storage temperature range	
transmitter only	-40 ... +80 °C (-40 ... +176 °F)
shipment package	-20 ... +80 °C (-4 ... +176 °F)
Mechanical connection	ISO G1/2", NPT 1/2", UNF 3/4"-16
Recommended calibration interval	2 years
Weight (ISO1/2")	190 g (6.70 oz)
Complies with EMC standard EN61326-1, Electrical equipment for measurement, control and laboratory use - EMC requirements;	
Industrial environment	

Accessories

Connection cable for MI70 indicator /DM70 meter	219980
USB connection cable	219690
Sampling cells	DMT242SC, DMT242SC2, DSC74, DSC74B, DSC74C
Flange	DM240FA
Loop-powered external display	226476
ISO 1/2" plug	218773
NPT 1/2" plug	222507

VAISALA

For more information, visit www.vaisala.com or contact us at sales@vaisala.com

Ref. B21159EN-B ©Vaisala 2011
This material is subject to copyright protection, with all copyrights retained by Vaisala and its individual partners. All rights reserved. Any logos and/or product names are trademarks of Vaisala or its individual partners. The reproduction, transfer, distribution or storage of information contained in this brochure in any form without the prior written consent of Vaisala is strictly prohibited. All specifications — technical included — are subject to change without notice.



DPT145 Multiparameter Transmitter for SF6 Gas



Features/Benefits

- First transmitter to offer online measurement of seven SF6 parameters in one unit
- Measured parameters: dew point, pressure, temperature
- Calculated parameters: SF6 density, normalized pressure, dew point in atmospheric pressure, ppm
- Saves time and money across the board, from investment and installation to operation and servicing
- More reliable assessment of the condition of SF6 insulation due to online measurement
- Long calibration interval of years

The Vaisala Multiparameter Transmitter DPT145 with the DILO DN20 connector.

The Vaisala Multiparameter Transmitter DPT145 for SF6 Gas is a unique innovation that enables online measurement of dew point, pressure, and temperature. It also calculates four other values, including SF6 density. The DPT145 is especially well suited for integration into OEM systems.

Online Reliability

Online dew point measurement combined with pressure measurement provides an excellent assessment of the condition of the SF6 insulation. Sudden and minor leakages are immediately detected by the direct normalized pressure measurement, while online dew point measurement alerts the user to moisture issues, which can weaken the insulation properties of SF6 and cause rapid deterioration. With the DPT145, it is also easy to build a redundant solution for multiple parameters.

Savings Across the Board

A single transmitter, instead of several, saves time and money

across the board, from investment to installation, operation and servicing. Lower assembly costs, fewer cables and connectors, minimized need for on-site visits and field operations - all these translate into cumulative savings. The long calibration interval results in further savings.

Risk-Free, Greener Solution

Online measurement enables gas trends to be followed via a data collection system, making monitoring fast, risk-free, and accurate. Using one instrument for monitoring seven

different parameters means also fewer mechanical connections and reduces the risk of leaks. Monitoring is environmentally friendly because there is no need for sampling - no SF6 gas is released into the atmosphere.

The Fruit of Experience

Vaisala has over 70 years of extensive measurement experience and knowledge. The DPT145 brings together the proven DRYCAP® dew point sensor technology and BAROCAP® pressure sensor technology in one package, providing an innovative and convenient solution for monitoring SF6 gas.



The DPT145 with the weather shield.

Technical Data

Measured Parameters

Dewpoint	-50 ... +30 °C (-58 ... +86 °F)
Pressure, absolute	1 ... 10 bar (14.5 ... 145 psi)
Temperature	-40 ... +80 °C (-40 ... +176 °F)

Calculated Parameters

Pressure, normalized to 20 °C (68 °F)	1 ... 12 bar (14.5...174 psi)
SF6 or SF6/N2 mixture density	0 ... 100 kg/m ³
ppm moisture, by volume	40 ... 40 000 ppm
Dewpoint, converted to atmospheric pressure	-65 ... +30 °C (-85 ... +86 °F)

Performance

Dewpoint accuracy	±3 °C (±5.4 °F), see graph below
Dewpoint stability	typical drift < 2 °C (3.6 °F) /5 years
Pressure accuracy at 23 °C (73.4 °F)	±0.4 %FS
Pressure temperature dependence	±0.1 %FS/10 °C (18 °F)
Pressure stability	typical drift < 1 %FS /5 years
Temperature accuracy	
0 ... 40 °C (+32 ... +104 °F)	±0.5 °C (± 0.9 °F)
-40...80 °C (-40 ... +176 °F)	±1 °C (± 1.8 °F)
Density accuracy (pure SF6, 1 ... 10 bara)	
0 ... 40 °C (+32 ... +104 °F)	±1 %FS
-40 ... +60 °C (-40 ... +140 °F)	±2.2 %FS
PPM accuracy, typical (5...1000 ppm, 7 bar)	±(7 ppm + 15% of reading)
Sensor response time:	
Pressure response time	< 1 s
Dewpoint response time* 63% [90%] at 20°C and 1 bar	
-50 -> -10 °C Tdf	5 s [10 s]
-10 -> -50 °C Tdf	10 s [2.5 min]

* system equilibrium related response time is typically longer

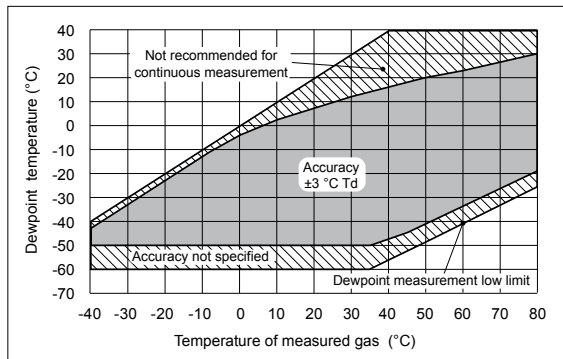

DPT145 Dewpoint Measurement Accuracy

Operating Environment

Operating temperature of electronics	-40 ... +60 °C (-40 ... +140 °F)
Operating Pressure	0 ... 50 bar (0...725 psi)
Relative humidity	0...100 %
Measured gases	SF ₆ , SF ₆ /N ₂ mixture

Outputs

Digital output	RS-485, non-isolated, Vaisala protocol
Connector	4-pin M8

General

Sensor	Vaisala MPS1 multiparameter sensor
Operating voltage	15 ... 28 VDC
20 ... 28 VDC in cold temperatures (-40 ... -20 °C (-40 ... -4 °F))	
Supply current, during normal measurement	20 mA
during self-diagnostics	max. 300 mA pulsed
Housing material	AISI316L
Housing classification	IP65 (NEMA4)
Weather shield to be used for continuous outdoor installations	
Storage temperature range	
transmitter only	-40 ... +80 °C (-40 ... +176 °F)
shipment package	-20 ... +80 °C (-4 ... +176 °F)
Mechanical connection	DILO DN20, ABB Malmkvist, or Alstom G1/2" compatible connector

Every connection is helium leak tested at the factory.

Dimensional drawings	See the document B211165EN-A
Weight (with DILO adapter)	765 g (27.0 oz)
Complies with EMC standard EN61326-1, Electrical equipment for measurement, control and laboratory use - EMC requirements;	
Industrial environment, Tested levels	
EN/IEC 61000-4-2, Electrostatic Discharge	8kV con / 15kV air
EN/IEC 61000-4-3, RF field immunity	10V/m (80MHz-4.2GHz)
EN/IEC 61000-4-4, Electric Fast Transient	±2kV power and signal
EN/IEC 61000-4-5, Surge	±2kV power line to ground / ±1kV signal line to ground and power line to line
EN/IEC 61000-4-6, Conducted RF	10Vemf power line and digital output
Immunity	
Mechanical vibration	
EN/IEC 60068-2-6, Fc Sinusoidal vibration	± 6 g, 5-500 Hz sweep 60 min/axis, 3-axis

Accessories

Connection cable for the MI70/DM70 hand-held	219980
USB connection cable	219690
Protection plug for connector	218675SP
1.5 m Shielded PUR cable with 90° connector	231519SP
3m Shielded PUR cable with 90° connector	231520SP
5 m Shielded PUR cable with 90° connector	231521SP
10 m Shielded PUR cable with 90° connector	231522SP
3.0m Shielded FEP cable with straight connector	226902SP
Weather shield	ASM210326SP

VAISALA

For more information, visit www.vaisala.com or contact us at sales@vaisala.com

Ref. B211160EN-A ©Vaisala 2011

This material is subject to copyright protection, with all copyrights retained by Vaisala and its individual partners. All rights reserved. Any logos and/or product names are trademarks of Vaisala or its individual partners. The reproduction, transfer, distribution or storage of information contained in this brochure in any form without the prior written consent of Vaisala is strictly prohibited. All specifications — technical included — are subject to change without notice.



Dimensional Drawings of the DPT145 Multiparameter Transmitter

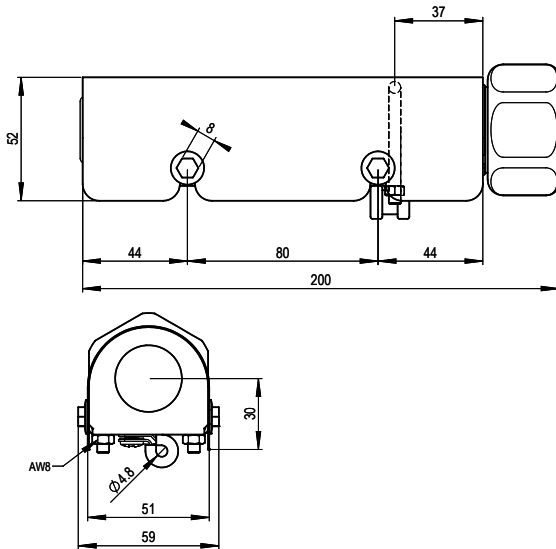

The DPT145 with the weather shield.

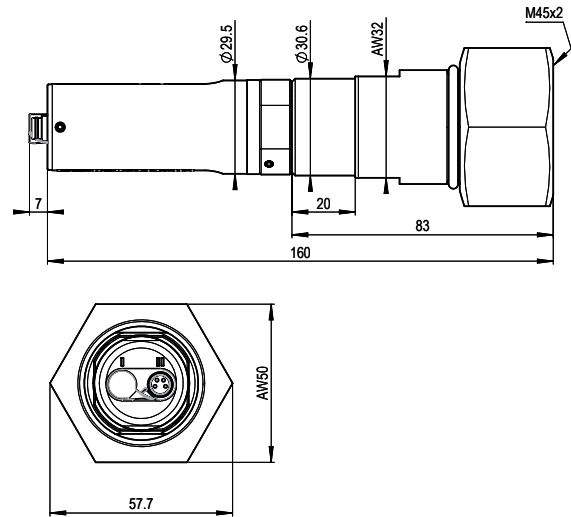

The DPT145 with the DILO DN20 connector.

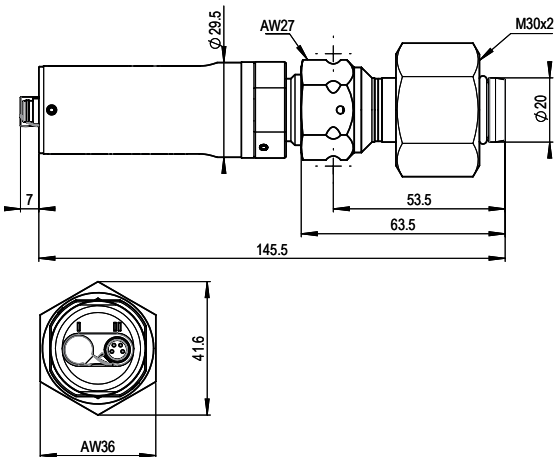

The DPT145 with the ABB Malmkvist connector.

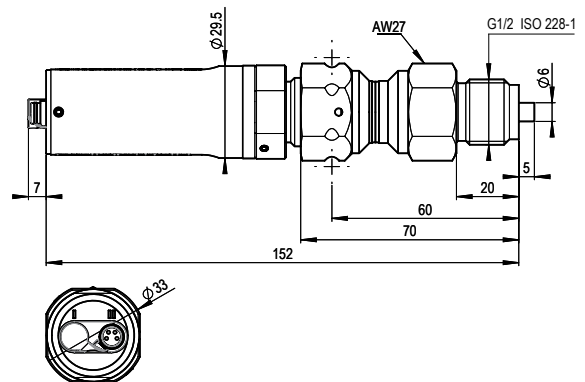

The DPT145 with the Alstom connector.



When Moisture is a Problem, Knowledge is Power. Literally.

Protect Your High-Voltage Assets.

How to revive an ageing fleet of high-voltage assets?
Can you extend network lifetime and ensure performance?
Just add knowledge – accurate, real-time moisture level information from **transformers, switchgear, turbines, generators and diesel engines**. It's easy, affordable and fast.

Plug in our on-line transmitters and in just minutes you are able to prevent rapid deterioration caused by moisture, boost performance, optimize maintenance and get extra years of safe peak performance.

For more information, please visit: www.vaisala.com/power



Providing solutions and services to customers in more than 120 countries. Thousands of installations in the power industry. Service centers in Finland, China, Japan and USA. Over 75 years of measurement expertise.

www.vaisala.com/power
sales@vaisala.com

VAISALA

MMT330 Moisture and Temperature Transmitter Series for Oil



The display shows measurement trends, real time data and history.

The MMT330 transmitter family offers a range of solutions for demanding moisture in oil measurements.

Features/Benefits

- Continuous on-line measurement of moisture in oil
- Ball valve installation - no need to shut down the process
- Proven Vaisala HUMICAP® Sensor, 15 years in oil applications.
- Easy to calibrate and maintain in the field - Compatible with Vaisala HUMICAP® Hand-Held Moisture for Oil Meter MM70
- NIST traceable calibration (certificate included)
- Analog outputs, WLAN/LAN
- MODBUS protocol support (RTU/TCP)
- Approved for Installation in lubrication system of MAN Diesel & Turbo Two-Stroke Diesel Engines.

The Vaisala HUMICAP® Moisture and Temperature Transmitter Series for Oil MMT330 enables fast and reliable detection of moisture in oil. The MMT330 can be used in on-line moisture monitoring and as a control device, allowing separators and oil driers to be started only when needed.

Proper monitoring saves both oil and the environment. With the MMT330 it is easy and economical to monitor the changes of moisture in oil.

Reliable Vaisala HUMICAP® Technology

The MMT330 incorporates the latest generation of the Vaisala HUMICAP® Sensor, which is the result of 15 years of field experience. It was developed for demanding moisture measurement in liquid hydrocarbons.

The sensor's excellent chemical tolerance provides accurate and reliable measurement over a wide measurement range.

For Diverse Applications and Demanding Conditions

Because of the variety of probes, the transmitter can be used in lubrication systems, hydraulic systems, and transformers.

Indicates the Margin to Water Saturation

The MMT330 measures moisture in oil in terms of the water activity (aw) and temperature (T). Water activity indicates directly whether there is a risk of free water formation. The measurement is also independent of oil type and age.

Water Content as ppm Conversion

In addition to water activity, the MMT330 can output ppm, the average mass concentration of water in oil. Vaisala has this conversion readily available for mineral transformer oil.

For other oils, the oil specific conversion coefficients can be programmed to the transmitter if the water solubility of the oil is known.

Graphical Measurement Trend and Historical Display

The MMT330 can be ordered with a large numerical and graphical display with a multilingual menu. It allows the user to monitor operational data, measurement trends and up to 1-year measurement history. The optional data logger with real-time clock makes it possible to generate over four years of measured history, and zoom in on any desired time or time frame.

The display alarm allows tracking of any measured parameter, with a freely configurable low and high limit.

Data Collection and (Wireless) Transfer to PC

The recorded measurement data can be viewed on the display or transferred to a PC with Microsoft Windows® software. The transmitter can also be connected to a network with an optional (W)LAN interface, which enables a (wireless) Ethernet connection.

Versatile Outputs and Easy Installation

The MMT330 provides up to three analog outputs. Galvanic isolation of supply power and analog outputs is also available. For serial interface the USB connection, RS232 and RS485 can be used. In addition, alarm relay option is available.

The MMT330 has several options for transmitter mounting. Transmitters



The Vaisala HUMICAP® Hand-Held Moisture for Oil Meter MM70 is designed for field checking MMT330 transmitters.

are delivered pre-configured with all settings installation ready.

MMT330 is also capable in applying the MODBUS communication protocol and together with an appropriate connection option provides either MODBUS RTU (RS485) or MODBUS TCP/IP (Ethernet) communication.



The MMT332 probe is installed using a flange. It is for high pressure applications.

Installation Options

MMT332 For High Pressure Installations

Pressure range	0 ... 250 bar / 0 ... 3625 psia
Probe diameter	12 mm / 0.5 inch
Installation	
Flange	36 mm / 1.4 inch
Temperature	
Measurement range	-40 ... +180 °C (-40 ... 356 °F)

Dimensions

Dimensions in mm (inches)

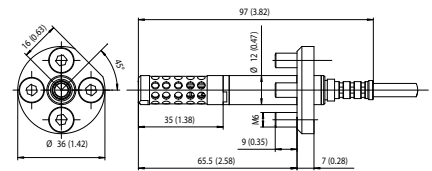

The MMT337 probe, with optional Swagelok connector, is ideal for tight spaces with a thread connection. The small probe is designed for integrating into confined spaces with small diameter lines.

Installation Options

MMT337 with Small Sized Probe

Pressure range	0 ... 10 bar / 0 ... 145 psia
Probe diameter	12 mm / 0.5 inch
Installation	
Fitting Body	R 3/8" ISO
Fitting Body	1/2" ISO
Fitting Body	NPT 1/2"
Temperature	
Measurement range	-40 ... +180 °C (-40 ... 356 °F)

Dimensions

Dimensions in mm (inches)

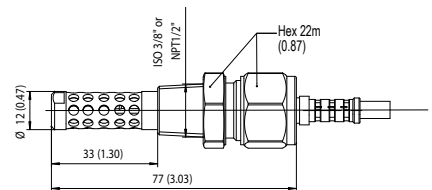

The MMT338 is ideal for installations in pressurized processes where the probe needs to be removed while the process is running. The probe depth is adjustable.

Installation Options

MMT338 with Probe for Pipeline Installations

Pressure range with ball valve	0 ... 40 bar / 0 ... 580 psia
	up to 120 °C (248 °F) and 40 bar
Adjustable length	35 ... 157/379 mm / 1.37 ... 6.2 / 14.9 inch
Installation	
Fitting Body	R1/2" ISO
Fitting Body	NPT 1/2"
Ball Valve Set	BALLVALVE-1
Sampling Cell	DMT242SC2
Temperature	
Measurement range	-40 ... +180 °C (-40 ... 356 °F)

Dimensions

Dimensions in mm (inches)

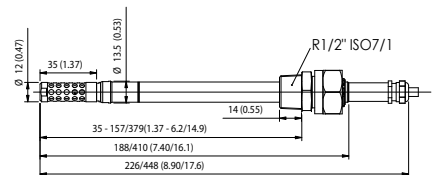

Technical Data

Measured Values

WATER ACTIVITY	
Measurement range a_w	0 ... 1
Accuracy (including nonlinearity, hysteresis and repeatability)	
0 ... 0.9	± 0.02
0.9 ... 1.0	± 0.03
Response time (90 %) at +20 °C in still oil (with stainless steel filter)	10 min.
Sensor	HUMICAP®

Performance

TEMPERATURE	
Measurement range	
MMT332	-40 ... +180 °C (-40 ... +356 °F)
MMT337	-40 ... +180 °C (-40 ... +356 °F)
MMT338	-40 ... +180 °C (-40 ... +356 °F)
Accuracy at +20 °C (+68 °F)	± 0.2 °C (0.36 °F)

Operating Environment

Operating temperature	
for probes	same as measurement ranges
for transmitter body	-40 ... +60 °C (-40 ... +140 °F)
with display	0 ... +60 °C (+32 ... +140 °F)
Pressure range for probes	See probe specifications

Complies with EMC standard EN61326-1, Electrical equipment for measurement, control and laboratory use - EMC requirements; Industrial environment.

Inputs and Outputs

Operating voltage	10 ... 35 VDC, 24 VAC
with optional power supply module	100 ... 240 VAC 50/60 Hz
Power consumption @ 20 °C (U_{in} 24VDC)	
RS-232	max 25 mA
U_{out} 2 x 0...1V / 0...5V / 0...10V	max 25 mA
I_{out} 2 x 0...20 mA	max 60 mA
display and backlight	+ 20 mA
Analog outputs (2 standard, 3rd optional)	
current output	0 ... 20 mA, 4 ... 20 mA
voltage output	0 ... 1 V, 0 ... 5 V, 0 ... 10 V
Accuracy of analog outputs at 20 °C	± 0.05 % full scale
Temperature dependence of the analog outputs	± 0.005 %/°C full scale
External loads	
current outputs	$R_L < 500$ ohm
0 ... 1V output	$R_L > 2$ kohm
0 ... 5V and 0 ... 10V outputs	$R_L > 10$ kohm

Max wire size	0.5 mm ² (AWG 20) stranded wires recommended
Digital outputs	RS-232, RS-485 (optional)
Protocols	ASCII commands, MODBUS RTU
Service connection	RS-232, USB
Relay outputs	0.5 A, 250 VAC, SPDT, Potential Free (optional)
Ethernet interface (optional)	
Supported standards	10BASE-T, 100BASE-TX
Connector	8P8C (RJ45)
IPv4 address assignment	DHCP (automatic), static
Protocols	Telnet, MODBUS TCP/IP
WLAN interface (optional)	
Supported standards	802.11b
Antenna connector type	RP-SMA
IPv4 address assignment	DHCP (automatic), static
Protocols	Telnet, MODBUS TCP/IP
Security	WEP 64/128, WPA
Authentication / Encryption	
Open / no encryption	
Open / WEP	
WPA Pre shared key / TKIP	
WPA Pre shared key / CCMP (a.k.a. WPA2)	
Optional data logger with real-time clock	
Logged parameters	max. four with trend/min/max values
Logging interval	10 sec (fixed)
Max. logging period	4 years 5 months
Logged points	13,7 million points per parameter
Battery lifetime	min. 5 years
Display	LCD with backlight, graphic trend display of any parameter
Display menu languages	English, Chinese, Spanish, German, French, Japanese, Russian, Swedish, Finnish

Mechanics

Cable bushing	M20x1.5 for cable diameter 8 ... 11mm/0.31 ... 0.43"
Conduit fitting	1/2"NPT
Interface cable connector (optional)	M12 series 8 pin (male)
option 1	with plug (female) with 5 m / 16.4 ft black cable
option 2	with plug (female) with screw terminals
USB-RJ45 Serial Connection Cable (incl. Mi70 Link software)	219685
Probe cable diameter	5.5 mm
Probe cable lengths	2 m, 5 m or 10 m
Housing material	G-AlSi 10 Mg (DIN 1725)
Housing classification	IP 65 (NEMA 4X)
Sensor protection	Stainless steel grid standard filter/ Stainless steel grid filter for high flow rates (>1 m/s)

Mounting Options



Mounting with Wall Mounting Kit



Mounting with DIN Rail Installation Kit



Pole Installation with Installation Kit for Pole or Pipeline



Mounting Rain Shield with Installation Kit

HUMICAP® is a registered trademark of Vaisala.

Dimensions

Dimensions in mm (inches)

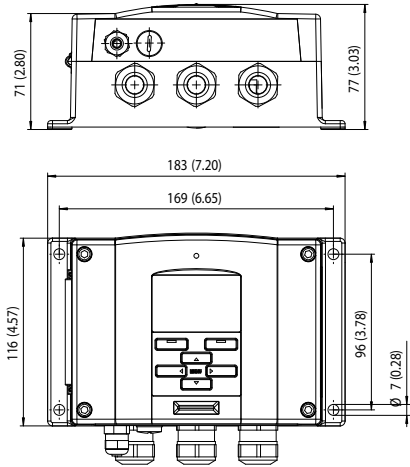

VAISALA

For more information, visit www.vaisala.com or contact us at sales@vaisala.com

Ref. B210953EN-B ©Vaisala 2011
 This material is subject to copyright protection, with all copyrights retained by Vaisala and its individual partners. All rights reserved. Any logos and/or product names are trademarks of Vaisala or its individual partners. The reproduction, transfer, distribution or storage of information contained in this brochure in any form without the prior written consent of Vaisala is strictly prohibited. All specifications — technical included — are subject to change without notice.



TYPE APPROVED PRODUCT
 CERTIFICATE NO.: A-11440



Don't measure the damage. Prevent it.

New intelligence for measuring moisture in oil.

- On-line, real time measurement without sampling
- Installation through ball valve - no need to shut down the process
- High stability in extreme conditions

Know your oil better -
Vaisala HUMICAP® instruments!

Download the 'Top 8 FAQs - Measuring moisture in oil' at www.vaisala.com/mioFAQ



Instruments display water activity trends.

MMT310 Series Moisture and Temperature Transmitter for Oil



Two probe options: MMT317 and MMT318

Features/Benefits

- Continuous measurement of moisture in oil
- Proven Vaisala HUMICAP® Sensor, 15 years in oil applications
- Measurements in lubrication, hydraulic and transformer oils
- Excellent pressure and temperature tolerance
- Measuring water activity - ppm calculation for transformer oil
- Small size, easy to integrate
- NIST traceable calibration
- Applications: e.g. monitoring of transformer oil and of lubrication systems in marine and paper industry

The Vaisala HUMICAP® Moisture and Temperature Transmitter Series for Oil MMT310 is a fast and reliable on-line detector for moisture in oil.

Reliable Vaisala HUMICAP® Technology

The MMT310 series incorporates the latest generation of the Vaisala HUMICAP® Sensor, developed for demanding moisture measurement in liquid hydrocarbons. The sensor's excellent chemical tolerance provides accurate and reliable measurement over the wide measurement range.

Measuring Water Activity

The MMT310 series measures moisture in oil in terms of the water activity (aw) and temperature (T).

Water activity directly indicates if there is a risk of free water formation. The measurement is independent of oil type, age, and temperature.

Water Content as PPM Calculation for Transformer Oils

PPM units are traditionally used in transformer applications. They indicate the average mass concentration of water in oil. The ppm calculation for mineral oil based transformer oil is optional in the MMT310 series.

Diverse Applications and Demanding Conditions

The MMT310 series can be used in lubrication and hydraulic systems as well as in transformers. It can be used for on-line moisture monitoring and as a control function, allowing separators and oil purifiers to be started only when necessary.

Installation Options

The MMT318 has two adjustable probe lengths. The transmitter can be ordered with a ball valve set that enables the insertion and removal of the moisture probe for calibration, without the need to empty the oil system.

The MMT317 has a small pressure-tight probe with optional Swagelok fittings.

Several Outputs, One Connector

The MMT310 series has two analog outputs and an RS-232 serial output. The output signals and the supply power travel in the same cable, the only cable connected to the unit.

Technical Data

Measured Values

WATER ACTIVITY		
Measurement range a_w		0 ... 1
Accuracy (including non-linearity, hysteresis and repeatability)		0 ... 0.9 ±0.02 0.9 ... 1.0 ±0.03
Response time (90 %) at +20 °C in still oil (with stainless steel filter)		10 min
Sensor		Vaisala HUMICAP®
TEMPERATURE		
Measurement range	-40 ... +180 °C (-40 ... +356 °F)	
Typical accuracy at +20 °C		±0.1 °C (±0.18 °F)
Typical temperature dependence of electronics		±0.05 °C/ °C (±0.005 °F/°F)
Sensor		Pt100 IEC751/3 class B

Electrical Connections

Two analog outputs, selectable and scalable		0 ... 20 mA or 4 ... 20 mA
Typical accuracy of analog output at +20 °C		±0.05 % full scale
Typical temperature dependence of analog output		0.005 %/°C (0.003 %/°F) full scale
Serial output		RS-232C
Connections		8-pole connector with RS-232C, current outputs (two channels) and U_{in}
Operating voltage U_{in}		24 VDC (10 ... 35 VDC)
Minimum operating voltage U_{in} with RS-232C		10 VDC
I_{out} 0 ... 20 mA, 4 ... 20 mA		11 VDC + ($R_{load}/60$) VDC
Power consumption at +20 °C, U_{in} = 24 VDC with RS-232C		20 mA
I_{out} 2 x 0 ... 20 mA		60 mA

Dimensions

Dimensions in mm (inches)

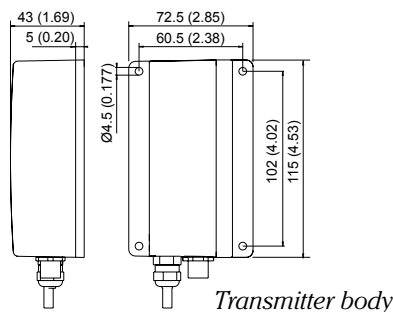

General

Operating temperature range for electronics		-40 ... +60 °C (-40 ... +140 °F)
Storage temperature		-55 ... +80 °C (-67 ... +176 °F)
Pressure range for MMT318 with ball valve up to 120 °C		0 ... 40 bar
Pressure range for MMT317		0 ... 10 bar
External load		$R_l < 500 \text{ Ohm}$
Material		transmitter housing: G-AlSi 10 Mg transmitter base: ABS/PC
Housing classification		IP65
Cable feed through alternatives		to be protected from direct rain 8-pole connector with 5 m cable, female 8-pin connector screw joint for cable diameter 4 ... 8 mm
Sensor protection		stainless steel grid standard filter stainless steel grid filter for high flow rates (>1 m/s)
Probe cable length		MMT317: 0.5, 2, 5 or 10 meters MMT318: 2, 5 or 10 meters
Probe installation MMT317		Swagelok®: NPT 1/2", ISO 3/8" or ISO 1/2"
Probe installation MMT318		Fitting bodies: ISO 1/2", NPT 1/2" Ball Valve Set: BALLVALVE-1
Complies with EMC standard EN61326-1, Industrial environment		

Note: When using the current output, the RF field susceptibility level according to standard EN61000-4-3 with a frequency band of 110 ... 165 MHz, is only 3 V/m (generic environment) with the specified accuracy.

HUMICAP® is a registered trademark of Vaisala.

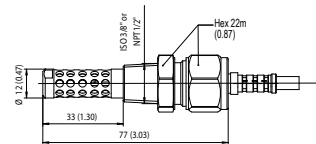

MMT317 probe

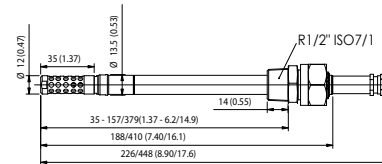

MMT318 probe

VAISALA

For more information, visit www.vaisala.com or contact us at sales@vaisala.com

Ref. B210831EN-B ©Vaisala 2011

This material is subject to copyright protection, with all copyrights retained by Vaisala and its individual partners. All rights reserved. Any logos and/or product names are trademarks of Vaisala or its individual partners. The reproduction, transfer, distribution or storage of information contained in this brochure in any form without the prior written consent of Vaisala is strictly prohibited. All specifications — technical included — are subject to change without notice.



MMT162 Compact Moisture in Oil and Temperature Transmitter for OEM Applications



The MMT162 enables on-line moisture monitoring in oils even in the most demanding applications.

Features/Benefits

- Continuous measurement of moisture in oil
- Measures in lubrication, hydraulic and transformer oils
- Excellent pressure and temperature tolerance
- Proven Vaisala HUMICAP® Sensor, 15 years in oil applications
- Measures water activity - ppm-calculation available for transformer oil
- Small size, easy to integrate
- NIST traceable calibration (certificate included)

The Vaisala HUMICAP® Moisture and Temperature Transmitter for Oil MMT162 is an excellent economical solution for reliable on-line detection of moisture in oil.

Reliable Vaisala HUMICAP® Technology

The MMT162 incorporates the latest generation of the Vaisala HUMICAP® Sensor. The sensor is developed for demanding moisture measurement in liquid hydrocarbons and has been successfully used in oil applications for over a decade. The sensor's excellent chemical tolerance provides accurate and reliable measurement over the measurement range.

Water Activity Measurement

The MMT162 measures moisture in oil in terms of the water activity (aw) and temperature (T). Water activity directly indicates whether there is a risk of free water formation. The measurement is independent of oil type, age and temperature. The ppm calculation for mineral oil based transformer oil is optional in the MMT162.

Several Outputs - One Connector

The MMT162 has two analog outputs that can be scaled and the measurement ranges changed. Additionally, the transmitter has an RS-485 serial output. The signals and the unit power travel in the same cable.

An optional LED-cable enables a visual alarm.

Compact, Rugged and Intelligent

Due to its compact size, the MMT162 is quickly and easily installed in tight spaces. Units are delivered fully assembled, however, you can re-configure them to suit your needs.

MM70

In combination with an MM70 indicator, the MMT162 provides an ideal tool for on site calibration. The MM70 indicator can be used as a display, communication, and data-logging device for the MMT162.

Technical Data

Measured Values

WATER ACTIVITY	
Measurement range	0 ... 1 aw
Accuracy (including non-linearity, hysteresis and repeatability)	
0 ... 0.9	± 0.02
0.9 ... 1.0	± 0.03
Response time	
in oil flow (typical)	<1 min (dry-wet)
MOISTURE	
Calculated moisture content in ppm for mineral transformer oil	
TEMPERATURE	
Accuracy at +20 °C (+68 °F)	± 0.2 °C (0.36 °F)

Operating Environment

Operating temperature	-40 ... +60 °C (-40 ... +140 °F)
Oil temperature	-40 ... +80 °C (-40 ... +176 °F)
Pressure range	
metal version	up to 200 bar
plastic version	up to 40 bar
Oil flow	some flow recommended

Outputs

Analog outputs (two channels)	
current output	0 ... 20 mA, 4 ... 20 mA
voltage output	0 ... 5 V, 0 ... 10 V
Alarm level indication by analog signal	user selectable
Digital outputs	RS-485

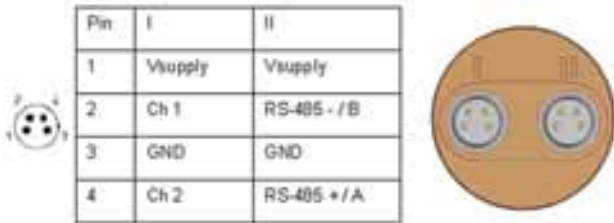

Dimensions

Dimensions in mm (inches)

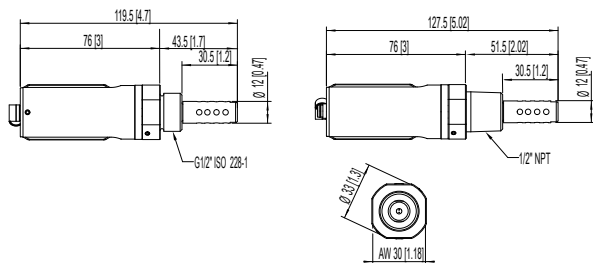

General

Sensor	HUMICAP®
Cable connections (2 ports)	M8, 4 pin
Minimum operating voltage with	
RS-485 output	14 ... 28 VDC
voltage output	16 ... 28 VDC
current output	22 ... 28 VDC
Supply current	
normal measurement	20 mA + load current
External load for	
voltage output	min. 10 kOhm
current output	max. 500 Ohm
Housing material	
metal	AISI 316L
plastic	PPS + 40% GF
Mechanical connections with bonded seal ring (washer)	
metal version	G 1/2" ISO or NPT 1/2"
plastic version	G 1/2" ISO
Housing classification	IP65 (NEMA 4)
Storage temperature range	-40 ... +80 °C (-40 ... +176 °F)
Weight	
with plastic housing	65 g (2.3 oz)
with metal housing	200 g (7 oz)
Complies with EMC standard EN61326-1, Electrical equipment for measurement control and laboratory use - EMC requirements; Industrial environment	

Options and Accessories

Stainless steel filter (standard)	225356SP
Stainless steel filter for high flow (>1 m/s)	221494SP
Connection cable for MM70 hand-held meter	219980
USB serial interface cable	219690
Sealing ring set (U-seal) ISO G1/2, 3 pcs	221525SP
Sealing ring set (copper) ISO G1/2, 3 pcs	221524SP
ISO 1/2" plug	218773
NPT 1/2" plug	222507
Sampling cell	DMT242SC
Sampling cell w. Swagelok connectors	DMT242SC2
Connection cable	
2 m (6.5 ft), M8 snap-on	211598
0.32 m (1 ft) Shielded, M8 threaded	HMP50Z032
3.0 m (9.8 ft), Shielded, M8 threaded	HMP50Z300SP
5.0 m (16.4 ft), Shielded, M8 threaded	HMP50Z500SP
10 m (32.8 ft), Shielded, M8 threaded	HMP50Z1000SP
3 m, Shielded, connector 90° angle	221739
5 m, Shielded, connector 90° angle	221740
M8 threaded, Ch 1 signal + Ch 2 LED	MP300LEDCBL

VAISALA

For more information, visit www.vaisala.com or contact us at sales@vaisala.com

Ref. B210755EN-C ©Vaisala 2011
This material is subject to copyright protection, with all copyrights retained by Vaisala and its individual partners. All rights reserved. Any logos and/or product names are trademarks of Vaisala or its individual partners. The reproduction, transfer, distribution or storage of information contained in this brochure in any form without the prior written consent of Vaisala is strictly prohibited. All specifications — technical included — are subject to change without notice.



MM70 Hand-Held Moisture and Temperature Meter for Spot-Checking in Oil



The MM70 is an ideal tool for the preventive maintenance of oil-filled systems. The water activity measurement indicates the margin to free water formation, which causes severe problems in lubrication systems.

Features/Benefits

- Measurement independent of oil type, age and temperature
- In-line process checking through ball valve, no need to drain the oil
- Rugged and reliable construction
- Excellent pressure and temperature tolerance
- Data can be logged and transferred to a PC
- Proven Vaisala HUMICAP® Sensor, 15 years in oil applications.
- Compatible with Vaisala's fixed oil moisture instruments
- No reference oil needed for recalibration
- NIST traceable (certificate included)

The Vaisala HUMICAP® Hand-held Moisture Meter for Oil MM70 enables reliable detection of moisture in oil.

In-Line Process Checking Through Ball Valve

The probe can be inserted directly into the process pipe through a ball valve without draining the oil in the system.

Water Activity Measurement

The MM70 measures moisture in oil in terms of the water activity (aw) and temperature (T). Water activity directly indicates whether there is a risk of free water formation. The measurement is independent of oil type, age and temperature.

PPM Calculation Included

The MM70 has an embedded model for expressing moisture as ppm in mineral transformer oil. The customer can enter up to three other oil models into the meter's memory.

Numerical and Graphical Display

The MM70 features a multilingual, menu-based user interface and a backlit LCD display. The measurement parameters can be numerically and graphically displayed and logged into the meter's memory at the same time. An analog output option is also available.

Connection to PC

The optional MI70 Link Windows® software in combination with a USB connection cable is used to transfer logged data and real time measurement data from the MM70 to a PC.

Proven Vaisala HUMICAP® Technology

The MM70 incorporates the latest generation of the Vaisala HUMICAP® Sensor, developed for demanding moisture measurements in liquid hydrocarbons. The sensor's excellent chemical tolerance provides accurate and reliable measurement over the measurement range.

Speedy Service - Once a Year

The meter can be recalibrated by sending the probe to Vaisala Service, or customers can calibrate the instrument themselves using a standard relative humidity calibration.

Multi-Probe Operation

One or two probes can be connected simultaneously. Maintenance teams can use additional Vaisala dew point or relative humidity probes for other tasks. For example, a dew point probe is ideal for checking the moisture inside washed and dried oil tanks.

Technical Data

Performance

WATER ACTIVITY

Measurement range a_w	0 ... 1
Accuracy (including nonlinearity, hysteresis and repeatability)	
When calibrated against salt solutions (ASTM E104-85):	
0 ... 0.9	±0.02
0.9 ... 1.0	±0.03
Maximum achievable accuracy when calibrated against high-quality, certified humidity standards:	
0 ... 0.9	±0.01
0.9 ... 1.0	±0.02
Response time (90%) at +20 °C (+68 °F) in still oil (with stainless steel filter)	10 min.
Sensor	Vaisala HUMICAP®
Recommended recalibration interval	1 year

TEMPERATURE

Measurement range	-40 ... +100 °C (-40 ... +212 °F)
Typical accuracy at +20 °C	±0.2 °C (±0.36 °F)
Typical temperature dependence of electronics	±0.005 °C/°C (±0.005 °F/°F)
Sensor	Pt 100 IEC 751 1/3 class B
Typical long-term stability	better than 0.01 aw / year

Operating Environment

PROBE

Operating temperature range for electronics	-40 ... +60 °C (-40 ... +140 °F)
Operating pressure range during installation through ball valve	max. 20 bar max. 10 bar
Oil flow range	max. 1 m/s

INDICATOR

Operating temperature range	-10 ... +40 °C (+14 ... +104 °F)
Operating humidity range	non-condensing

ELECTROMAGNETIC COMPATIBILITY

Complies with EMC standard EN61326-1, Electrical equipment for measurement, control and laboratory use - EMC requirements; Portable equipment.

Inputs and Outputs

Power supply	Rechargeable NiMH battery pack with AC-adaptor or 4xAAA-size alkalines, type IEC LR6
Battery operation time	
continuous use	48 h typical at +20 °C (+68 °F)
data logging use	up to a month, depending on logging interval
Menu languages	English, Chinese, Spanish, French, German, Japanese, Russian, Swedish, Finnish

Display	LCD with backlight, graphic trend display of any parameter, character height up to 16 mm
Analog output	0 ... 1 VDC
Output resolution	0.6 mV
PC interface	MI70 Link software with USB or serial port cable
Data logging capacity	2700 points
Alarm	Audible alarm function

Mechanics

PROBE

Housing classification	IP65 (NEMA 4)
Housing material	ABS/PC blend
Probe material	Stainless steel (AISI316L)
Cable length between probe and indicator	1.9 m, 10 m extension available
Weight	506 g

INDICATOR

Housing classification	IP54
Weight	400 g
Probe inputs	1 or 2

Options and Accessories

Carrying case	MI70CASE2
Ball valve set (incl. fitting body & blanking plug)	HMP228BVS
Probe cable extension, 10 m	213107SP
Transmitter connection cables for	
MMT162	219980
MMT310	DRW216050
MMT330	211339
MI70 Link software with USB cable	219687
MI70 Link software with serial port cable	MI70LINK
Analog output cable	27168ZZ
Sensor protection	HM47453SP
Dew point measurement probes	DMP74A/B
Relative humidity measurement probes	HMP75, HMP76, HMP77

Dimensions

Dimensions in mm (inches)

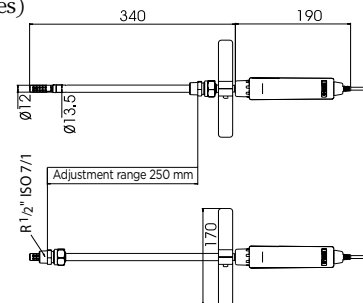

HUMICAP® is a registered trademark of Vaisala.

VAISALA

For more information, visit www.vaisala.com or contact us at sales@vaisala.com

Ref. B210960EN-B ©Vaisala 2011
This material is subject to copyright protection, with all copyrights retained by Vaisala and its individual partners. All rights reserved. Any logos and/or product names are trademarks of Vaisala or its individual partners. The reproduction, transfer, distribution or storage of information contained in this brochure in any form without the prior written consent of Vaisala is strictly prohibited. All specifications — technical included — are subject to change without notice.



GMP343 Carbon Dioxide Probe for Demanding Measurements



Features/Benefits

- Excellent accuracy and stability
- Vaisala CARBOCAP® Sensor, a silicon-based non-dispersive infrared (NDIR) sensor
- A single-beam, dual-wavelength CO₂ measurement with no moving parts
- Compensation options for temperature, pressure, humidity and oxygen
- Low power consumption and heat emission
- Designed for outdoor use
- Compact and lightweight

The GMP343 is available as an open-path diffusion-aspirated model (left) and as a flow-through model (right).

The Vaisala CARBOCAP® Carbon Dioxide Probe GMP343 is an accurate and rugged probe-type instrument for ecological measurements. Typical applications include CO₂ soil respiration, ambient CO₂ monitoring, plant growth chambers, and OEM applications.

The GMP343 can output both numerically filtered and raw measurement data and it can also compensate the measurement with an internal temperature measurement and user-set relative humidity, pressure and oxygen values.

In combination with an MI70 indicator, the GMP343 provides a tool for accurate in-situ measurement. The MI70 can be used as a display, communication and data logging device.

Each GMP343 is calibrated using ±0.5 % accurate gases at 0 ppm, 200 ppm, 370 ppm, 600 ppm, 1000 ppm, 4000 ppm and 2 %. Calibration is also done at temperature points of -30 °C, 0 °C, 25 °C and 50 °C. If needed, the customer can recalibrate the instrument using the multipoint calibration (MPC) feature allowing up to 8 user-defined calibration points.

Technical Data

Performance

Measurement range options	0 ... 1000 ppm, 0 ... 2000 ppm, 0 ... 3000 ppm, 0 ... 4000 ppm, 0 ... 5000 ppm, 0 ... 2 %
---------------------------	---

Accuracy (excluding noise) at 25 °C (77 °F) and 1013 hPa after factory calibration with 0.5 % accurate gases with different range options	
0 ... 1000 ppm	±(3 ppm + 1 % of reading)
0 ... 2000 ppm - 0 ... 2 %*	±(5 ppm + 2 % of reading)

*Accuracy below 200 ppm CO₂ not specified for 2 % range option

Noise (repeatability) at 370 ppm CO ₂	
with no output averaging	±3 ppm CO ₂
with 30 s output averaging	±1 ppm CO ₂

TEMPERATURE

Effect on accuracy **with** temperature compensation:

CO ₂ range options	0 ... 1000 ppm	0 ... 2 000 - 5000 ppm	0 ... 2 %
Temperature °C (°F)	Accuracy (% of reading)		
+10 ... +40 (+50 ... +104)	±1	±1	±2
+40 ... +60 (+104 ... +140)	±2	±3	±4
-40 ... +10 (-40 ... +50)	±3	±3	±5

For readings below 200 ppm CO₂ ±5 ppm CO₂
Temperature compensation is performed by an integrated Pt1000 element

Technical Data

PRESSURE

Effect on accuracy **with** pressure compensation:

CO ₂ range options	0 ... 1000 ppm	0 ... 2000 - 2 %
Pressure (hPa)	Accuracy (% of reading)	
900 ... 1050	±0.5	±1
700 ... 1300	±1	±2

Integrated pressure sensor is **not** included in GMP343

Long term stability	see graph below
easy	<±2 % of reading / year
moderate	<±2 % of reading / 6 months
harsh	<±2 % of reading / 3 months

GMP343 OPERATING CONDITIONS

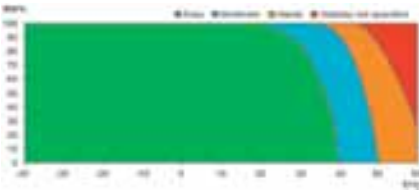

Response time (90 %)

DIFFUSION MODEL		
Filter attached	Averaging (s)	Response (s)
Yes	0	75
Yes	30	82
No	0	<2
No	30	30

FLOW-THROUGH MODEL		
Gas flow (l/min)	Averaging (s)	Response (s)
0.3	0	26
0.3	30	44
1.2	0	8
1.2	30	23

Warm-up time	
full accuracy ±0.5 %	10 min
full accuracy	30 min

Operating Environment

Temperature	
operating	-40 ... +60 °C (-40 ... +140 °F)
storage	-40 ... +70 °C (-40 ... 158 °F)
Humidity	see graph 'GMP343 Operating Conditions'
Pressure	
compensated range	700 ... 1300 hPa
operating	<5 bar
Gas flow for flow-through model	0 ... 10 liters/min
Electromagnetic compatibility	EN61326, Generic Environment

Inputs and Outputs

Operating voltage	11 ... 36 VDC
Power consumption	
without optics heating	<1 W
with optics heating	<3.5 W
ANALOG OUTPUTS	
Current output	
range	4 ... 20 mA
resolution	14 bits
max. load	800 Ohm @ 24 VDC, 150 Ohm @ 10 VDC
Voltage output	
range	0 ... 2.5 V, 0 ... 5 V
resolution	14 bits (13 bits with 0 ... 2.5 V)
min. load	5 kOhm
DIGITAL OUTPUTS	
	RS485, RS232

Materials

Housing	anodized aluminium
Filter cover	PC
IP classification	<1 W
Housing (cable attached)	IP67
Diffusion filter (weather protection)	IP65
Diffusion filter (sintered PTFE)	IP66
Cable connector type	8-pin M12
Weight (probe only)	360 g

Options and Accessories

Wall mount bracket	GMP343BRACKET
Mounting flange	GMP343FLANGE
Standard diffusion filter (weather protection, IP65) + filter cover	GMP343FILTER
Diffusion filter (sintered PTFE filter, IP66) + filter cover	215521
Calibration adapter (for the diffusion model)	GMP343ADAPTER
Junction box	JUNCTIONBOX-8
Probe cables	
2m	GMP343Z200SP
6m	GMP343Z600SP
10m	GMP343Z1000SP
PC connection cable, 2m	213379
MI70 connection cable, 2m	DRW216050SP
USB adapter (USB-D9 Serial connection cable)	219686
Soil adapter kit for horizontal positioning	215519
Soil adapter kit for vertical positioning	215520

VAISALA

For more information, visit www.vaisala.com or contact us at sales@vaisala.com

Ref. B210688EN-B ©Vaisala 2009
This material is subject to copyright protection, with all copyrights retained by Vaisala and its individual partners. All rights reserved. Any logos and/or product names are trademarks of Vaisala or its individual partners. The reproduction, transfer, distribution or storage of information contained in this brochure in any form without the prior written consent of Vaisala is strictly prohibited. All specifications — technical included — are subject to change without notice.



GMT220 Series Carbon Dioxide Transmitters for Industrial Applications

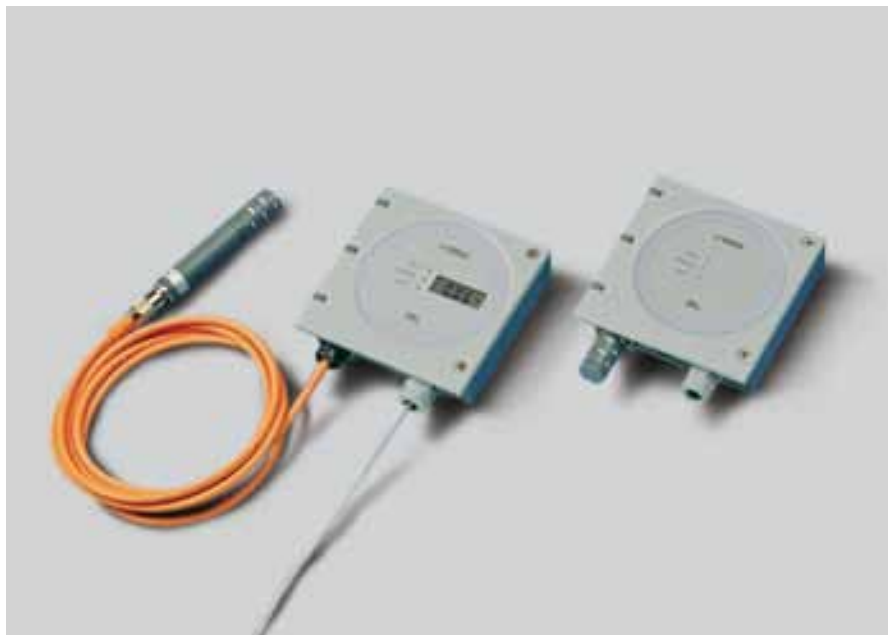

The GMT220 transmitters withstand harsh and humid environments.

Features/Benefits

- Incorporates Vaisala CARBOCAP® - the silicon-based NDIR sensor
- IP65 protected against dust and spray water
- Several measurement ranges
- Easy installation
- Standard analog outputs and two configurable relays available

Applications include:

- Horticulture and fruit storage
- Greenhouses and mushroom farming
- Safety alarming and leakage monitoring
- Demand controlled ventilation in harsh environments

The Vaisala CARBOCAP® Carbon Dioxide Transmitter Series GMT220 is designed to measure carbon dioxide in harsh and humid environments. The housing is dust- and waterproof to IP65 standards.

The GMT220 series transmitters incorporate the advanced Vaisala CARBOCAP® Sensor. The patented sensor has unique reference measurement capabilities. Its critical parts are made of silicon; this gives the sensor outstanding stability over both time and temperature. By lengthening the calibration intervals, the user saves both time and money.

Interchangeable Probes

The user has a choice of measurement ranges up to 20% of CO₂. The GMT221 is for higher concentrations of CO₂ and the

GMT222 for lower concentrations of CO₂. The GMT220 probes are interchangeable. They can be removed and reattached or replaced at any time – without the need for calibration and adjustment. The probes can be attached directly to the transmitter body or, when used with a cable, installed remotely into hard-to-reach places or areas with dangerously high levels of CO₂.

The interchangeability of the GMT220 transmitter's probes truly facilitates field maintenance.

The end user can carry out field maintenance without any additional equipment or heavy and expensive calibration gas bottles by simply replacing a probe.

Probes that have been replaced can be sent to Vaisala for recalibration.

Technical Data

Performance

Measurement Ranges	
GMT221	0 ... 2 %
for high concentrations	0 ... 3 %
	0 ... 5 %
	0 ... 10 %
	0 ... 20 %
GMT222	0 ... 2000 ppm
for low concentrations	0 ... 3000 ppm
	0 ... 5000 ppm
	0 ... 7000 ppm
	0 ... 10 000 ppm
Accuracy (including repeatability, non-linearity and calibration uncertainty) at 25 °C and 1013 hPa	
GMT221	±(1.5 % of range + 2 % of reading)
(applies for concentrations above 2 % of full scale)	
GMT222	±(1.5 % of range + 2 % of reading)
Temperature dependence, typical	-0.3 % of reading / °C
Pressure dependence, typical	+0.15 % of reading/hPa
Long-term stability	<±5 %FS/2 years
Response time (63 %)	
GMT221	20 seconds
GMT222	30 seconds
Warm-up time	30 seconds, 15 minutes full specifications

Inputs and Outputs

Outputs	0 ... 20 or 4 ... 20 mA and 0 ... 10 V
Resolution of analog outputs	12 bits
Recommended external load:	
current output	max. 400 Ohm
voltage output	min. 1 kOhm
Two pre- or user-defined relay outputs	
Relay contacts	max. 30VAC/60VDC, 0.5A
Connections	screw terminals, 0.5 ... 1.5 mm ²
Operating voltage	nominal 24 VAC/DC
Power consumption	<4 W

Operating Environment

Operating temperature	-20 ... +60 °C (-4 ... +140 °F)
with display	0 ... +50 °C (+32 ... +122 °F)
Storage temperature	-30 ... +70 °C (-22 ... +158 °F)
Operating pressure (compensated range)	700 ... 1300 hPa
Humidity	0 ... 100 %RH, non-condensing
Electromagnetic compatibility	EN61326-1, Generic Environment

Mechanics

Housing material	
transmitter body	ABS plastic
probe	PC plastic
Housing classification	IP65
Weight:	
GMT221	max. 280 g
GMT222	max. 300 g
Probe cable length	2 m and 10 m (optional)

Accessories

Spare probe	GMP221, GMP222 (use the order form to define measurement range etc.)
Clips (2 pcs) for attaching the probe	25245GM
Mounting flange for the probe	GM45156
Probe cables	
2 m	25665GMSP
10 m	210848GMSP
Calibrator for interchangeable probes	GMK220
Wall Assembly Plate	GM45160
In-soil adapter for probe	211921GM
Serial COM adapter	19040GM
Calibration adapter for probe	26150GM

Dimensions

Dimensions in mm (inches)

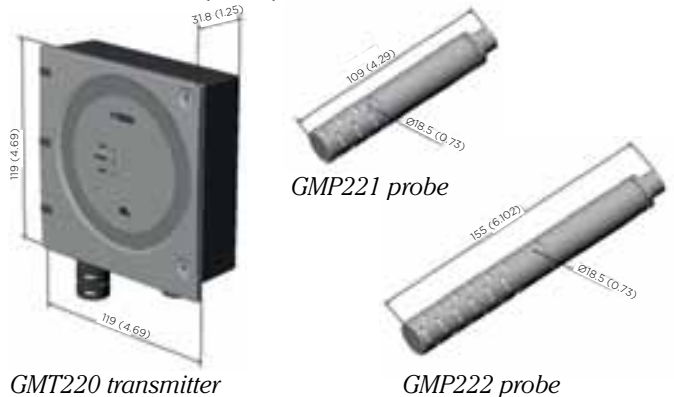

VAISALA

For more information, visit www.vaisala.com or contact us at sales@vaisala.com

Ref. B210827EN-C ©Vaisala 2011
This material is subject to copyright protection, with all copyrights retained by Vaisala and its individual partners. All rights reserved. Any logos and/or product names are trademarks of Vaisala or its individual partners. The reproduction, transfer, distribution or storage of information contained in this brochure in any form without the prior written consent of Vaisala is strictly prohibited. All specifications — technical included — are subject to change without notice.



GMM220 Carbon Dioxide Modules for Demanding OEM Applications

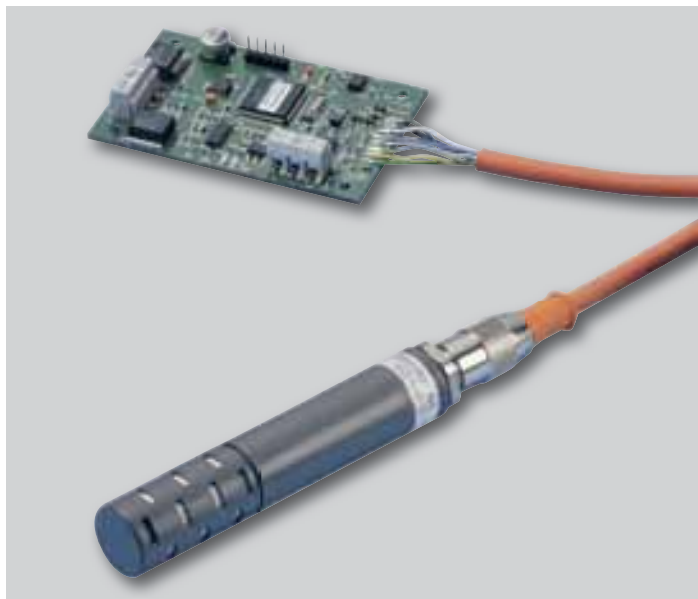

The Vaisala CARBOCAP® Carbon Dioxide Module Series GMM220 withstand harsh conditions. They provide high carbon dioxide measurement accuracy over wide temperature and relative humidity ranges.

Features/Benefits

- Incorporates Vaisala CARBOCAP® - the silicon based CO₂ sensor
- Choice of several measurement ranges
- IP65 protected probe against dust and spray water
- Interchangeable probes provide easy maintenance
- Modules optimized for integration into equipment for greenhouse control, incubators, fermentors, safety alarming and integrated systems.

For Harsh Environments

The Vaisala CARBOCAP® Carbon Dioxide Module Series GMM220 are designed for Original Equipment Manufacturers (OEM's) requiring carbon dioxide measurements in harsh and demanding applications.

Vaisala CARBOCAP®

The GMM220 series modules incorporate the industrial Vaisala CARBOCAP® Sensor. The patented sensor has unique reference measurement capabilities. Its critical parts are made of silicon; this gives the sensor outstanding stability over both time and temperature.

Since water vapor, dust, and most chemicals do not affect the measurement, the GMM220 series modules can be used in harsh and humid environments.

Interchangeable Probes

The GMP220 probes are interchangeable. They can be removed, reattached or replaced at any time – without the need for calibration and adjustment. The interchangeable probes make calibration and field service easy. In addition, the measurement range can be changed simply by replacing one probe with another.

Different Configurations

The user has a choice of measurement ranges up to 20 % CO₂; the Vaisala CARBOCAP® Carbon Dioxide Module GMM221 for higher and the Vaisala CARBOCAP® Carbon Dioxide Module GMM222 for lower concentrations of CO₂.

Different power supply voltages, output options, as well as cable lengths, connectors, and mounting gear are also available.

Technical Data

Carbon Dioxide

Measurement ranges	
GMM221 for high concentrations	0 ... 2 %, 0 ... 3 %, 0 ... 5 %, 0 ... 10 %, 0 ... 20 %
GMM222 for low concentrations	0 ... 2000 ppm, 0 ... 3000 ppm, 0 ... 5000 ppm, 0 ... 7000 ppm, 0 ... 10 000 ppm
Accuracy (including repeatability, non-linearity and calibration uncertainty) at 25 °C and 1013 hPa	
GMM221	±(1.5% of range + 2% of reading)
(applies for concentrations above 2% of full scale)	
GMM222	±(1.5% of range + 2% of reading)
Temperature dependence, typical	-0.3 % of reading / °C
Pressure dependence, typical	+0.15% of reading hPa
Long-term stability	<±5 %FS/2 years
Response time (63 %)	
GMM221	20 seconds
GMM222	30 seconds
Warm-up time	30 seconds, 15 minutes full specifications

Inputs and Outputs

Outputs	0 ... 20 or 4 ... 20 mA, 0 ... 1 V, 0 ... 2V, 0 ... 2.5 V, or 0 ... 5 V
Resolution of analog outputs	12 bits
Recommended external load:	
current output	max. 200 Ohm
voltage output	min. 1 kOhm
Operating voltage	11 ... 20 VDC or 18 ... 30 VDC
Connections	screw terminals, wire size 0.5 ... 1.5 mm ²
Power consumption	<2.5 W

Operating Environment

Operating temperature	-20 ... +60 °C (-4 ... +140 °F)
Storage temperature	-30 ... +70 °C (-22 ... +158 °F)
Operating pressure	700 ... 1300 hPa
Humidity	
probe	0 ... 100 %RH, non-condensing
mother board	0 ... 85 %RH, non-condensing
Electromagnetic compatibility	EN61326-1, Generic Environment

Mechanics

Probe housing material	PC plastic
Housing classification (probe only)	IP65
Weight: GMM221 (w/2m cable)	max. 180 g
Weight: GMM222 (w/2m cable)	max. 200 g
Probe cable length	0.6 m, 1 m (high temperature cable), 2 m, 6 m or 10 m (optional)

Accessories

Spare probe	GMP221, GMP222
(use the order form to define measurement range etc.)	
Clips (2 pcs) for attaching the probe	25245GM
Mounting flange for the probe	GM45156
CO ₂ Calibration Unit	GMK220
Probe cables	
1 m high temperature probe cable (180 °C / 365 °F)	GMM220Z100SP
2 m probe cable	GMM220Z200SP
6 m probe cable	GMP343Z600SP
10.0 m probe cable	GMP343Z1000SP
Serial COM adapter	19040GM

Dimensions

Dimensions in mm (inches)

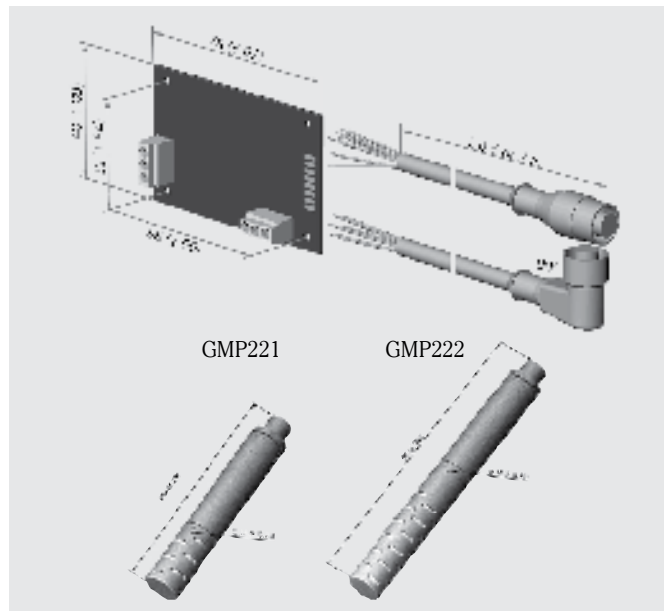

VAISALA

For more information, visit www.vaisala.com or contact us at sales@vaisala.com

Ref. B210856EN-D ©Vaisala 2011
This material is subject to copyright protection, with all copyrights retained by Vaisala and its individual partners. All rights reserved. Any logos and/or product names are trademarks of Vaisala or its individual partners. The reproduction, transfer, distribution or storage of information contained in this brochure in any form without the prior written consent of Vaisala is strictly prohibited. All specifications — technical included — are subject to change without notice.



GMM111 Carbon Dioxide Module



The Vaisala CARBOCAP® Carbon Dioxide Module GMM111 is a CO₂ measurement module with flow-through aspiration.

Features/Benefits

- Compact CO₂ module with flow-through aspiration
- Ideal for control of CO₂ concentrations in incubators
- Incorporates Vaisala CARBOCAP®, the silicon based NDIR sensor with unique internal referencing
- Advanced single-beam, dual wavelength measurement with no moving parts
- Measurement range options 0 ... 5 %, 0 ... 10 % and 0 ... 20 % CO₂
- Excellent long-term stability

GMM111

The Vaisala CARBOCAP® Carbon Dioxide Module GMM111 is designed especially for control of biological processes where high CO₂ concentrations are used. It has 3 optional measurement ranges 0 ... 5/10/20 % CO₂. The GMM111 is a flow-through model and has barbed connectors for attaching the in and out flow tubes. As the module is not mounted in the chamber, the chamber can be heatsterilized without removing the module.

The Vaisala CARBOCAP® CO₂ sensors have been proven to be accurate and durable. They have an excellent long-term stability, which decreases maintenance. The superior performance of Vaisala

CARBOCAP® sensors results largely from the stable reference provided by the electrically tunable Fabry-Perot Interferometer(FPI).

The tunable FPI filter measures CO₂ absorption, and simultaneously a reference wavelength. This internal reference measurement compensates effectively for any changes in the optical path, such as light source intensity changes and contamination. In the HVAC market, this type of reference measurement is a unique feature to Vaisala CARBOCAP® products.

The true internal reference measurement of Vaisala CARBOCAP® CO₂ transmitters provides years of stable CO₂ measurements.

Technical Data

Performance

CO ₂ measurement range	0 ... 5 %, 0 ... 10 % or 0 ... 20 %
Accuracy (including repeatability, non-linearity and calibration uncertainty)	±(1.5% of range + 3 % of reading)
Long-term stability	±5 % FS/2 years
Response time T ₉₀	1 min at 0.5 l/min flow
Flow rate dependence	
< 1 l/min flow	no effect
1 ... 10 l/min flow	4 % of reading/ l/min
Temperature dependence, typical	-0.3 % of reading/°C
Pressure dependence, typical	+0.15 % of reading/hPa
Warm-up time	1 min, 10 min for full specifications
Product lifetime	> 10 years

Operating Environment

Temperature	+5 ... +55 °C (+41 ... +131 °F)
Humidity	0 ... 99 % RH non-condensing
Pressure	700 ... 1200 hPa
Gas flow	
operating range	< 10 l/min
recommended range	0.2 ... 0.8 l/min
Electromagnetic compatibility	
Complies with EMS Standard EN61326-1, Generic Environment	

Inputs and Outputs

Outputs	4 ... 20 mA, 0 ... 10 V
	RS485, 2-wire, non-isolated
Operating voltage	24 V (±20 %) AC/DC
Power consumption	< 2 W

Dimensions

Dimensions in mm

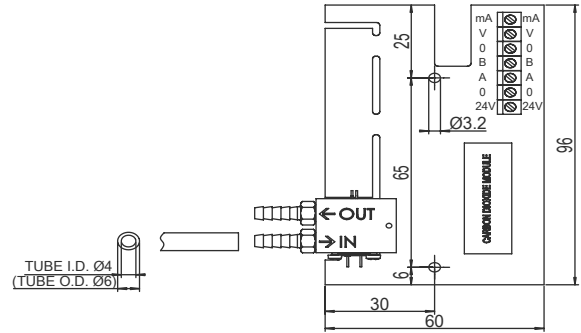

VAISALA

For more information, visit www.vaisala.com or contact us at sales@vaisala.com

Ref. B210566EN-C ©Vaisala 2011
 This material is subject to copyright protection, with all copyrights retained by Vaisala and its individual partners. All rights reserved. Any logos and/or product names are trademarks of Vaisala or its individual partners. The reproduction, transfer, distribution or storage of information contained in this brochure in any form without the prior written consent of Vaisala is strictly prohibited. All specifications — technical included — are subject to change without notice.



GM70 Hand-Held Carbon Dioxide Meter for Spot-Checking Applications



The Vaisala CARBOCAP® Hand-Held Carbon Dioxide Meter GM70 is the demanding professional's choice for hand-held carbon dioxide measurement. The meter consists of the indicator (center) and probe, used either with the handle (left) or pump (right).

Features/Benefits

- Proven Vaisala CARBOCAP® reliability
- Two optional sampling methods: diffusion or pump aspiration
- User-friendly meter with multilingual user interface
- Numerical and graphical display of measurements
- Data can be logged and transferred to PC via MI70 Link software
- Wide selection of measurement ranges
- Easy recalibration using the interchangeable probes
- Suitable for field checking of fixed CO₂ instruments
- Short warm-up time
- Compact and versatile

The Vaisala CARBOCAP® Hand-Held Carbon Dioxide Meter GM70 is a user-friendly meter for demanding spot measurements in laboratories, greenhouses and mushroom farms. The meter can also be used in HVAC and industrial applications, and as a tool for checking fixed CO₂ instruments. The GM70 has a short warm-up time and is ready for use almost immediately. It has a menu-based interface, a graphical LCD display and data logging capability. The optional MI70 Link Windows® software in combination with a USB connection cable provides an easy way to handle data in a PC environment.

Vaisala CARBOCAP® Technology

The GM70 incorporates the advanced Vaisala CARBOCAP® sensor that has unique reference measurement capabilities. The measurement

accuracy is not affected by dust, water vapor or most chemicals. The GM70 has a two-year recommended calibration interval.

Two Sampling Methods

The handle is for hand-held diffusion sampling. The GM70 pump enables pump-aspirated sampling from locations difficult to access otherwise. It is also ideal for comparisons with fixed CO₂ transmitters.

Interchangeable Probes

The GM70 uses the same probes as Vaisala CARBOCAP® Carbon Dioxide Transmitter Series GMT220 and Modules Series GMM220. By plugging different probes into the handle or pump, the user can easily change the measurement range of the GM70. The meter can also be used as a calibration check instrument for Vaisala's GM20 and series, GMT/M220 fixed CO₂ instruments. GMP220 probes can even be adjusted by using the GM70 meter.

The GM70 has two probe inputs. Vaisala's relative humidity and dewpoint probes can also be used simultaneously with CO₂ measurement.

Technical Data

CO₂ Volume Concentration Measurement

Measurement ranges	
High concentrations	0 ... 2 %
short probe (GMP221)	0 ... 3 %
	0 ... 5 %, 0 ... 10 %, 0 ... 20 %
Low concentrations	0 ... 2000 ppm
long probe (GMP222)	0 ... 3000 ppm, 0 ... 5000 ppm, 0 ... 7000 ppm, 0 ... 10,000 ppm
Accuracy (including repeatability, non-linearity and calibration uncertainty) at 25 °C and 1013 hPa	
GMP221	±(1.5% of range + 2% of reading)
(applies for concentrations above 2% of full scale)	
GMP222	±(1.5% of range + 2% of reading)
Temperature dependence, typical	-0.3 % of reading / °C
Pressure dependence, typical	+0.15% of reading/hPa
Long-term stability	<±5 %FS/2 years
Response time (63 %)	
GMP221	20 seconds
GMP222	30 seconds
Warm-up time	30 seconds, 15 minute full specifications

Measurement Environment

Temperature	-20 ... +60 °C (-4 ... +140 °F)
Relative humidity	0 ... 100 %RH non-condensing
Operation pressure	700 ... 1300 hPa
Flow range (diffusion sampling)	0 ... 10 m/s

Probe, Handle & Pump General

Sensor	Vaisala CARBOCAP®
Housing material	
GMP221/222 probe	PC plastic
GMH70 handle	ABS/PC blend
GM70 Pump	aluminium casing
Storage temperature	-30 ... +70 °C (-22 ... +158 °F)
Storage humidity	0 ... 100 %RH non-condensing
Weight	
GMH70 with GMP221/222 probe	230 g
GM70 Pump with GMP221/222 probe	700 g

MI70 Indicator General

Menu languages	English, Chinese, French, Spanish, German, Japanese, Russian, Swedish, Finnish
Display	LCD with backlight, graphic trend display of any parameter, character height up to 16 mm
Max. no. of probes	2
Power supply	Rechargeable NiMH battery pack with AC-adaptor
Analog output	0 ... 1 VDC
Output resolution	0.6 mV
PC interface	MI70 Link software with USB or serial port cable
Data logging capacity	2700 points
Alarm	Audible alarm function
Operating temperature range	-10 ... +40 °C (+14 ... +104 °F)
Operating humidity range	non-condensing
Housing material	ABS/PC blend
Housing classification	IP54
Weight	400 g

Battery Operation Time

Continuous use	
with handle	better than 8h at +20 °C (+68 °F)
with pump	better than 5h at +20 °C (+68 °F) without load
Data logging use	up to a month, depending on logging interval

Electromagnetic Compatibility

EN 61326-1, Portable Equipment.

Accessories

Connection cable for fixed CO ₂ instruments	
GMT220, GMM220, GMD20 and GMW20	GMA70
MI70 Link software with USB cable	219687
MI70 Link software with serial port cable	MI70LINK
Analog output cable for 0 ... 1 VDC	27168ZZ
Calibration adapter	26150GM
Carrying case	MI70CASE
Battery, NiMH 4.8V	26755
Spare probe	GMP221, GMP222
(use the order form to define measurement range etc.)	
Nafion Membrane Tubing	212807GM

VAISALA

For more information, visit www.vaisala.com or contact us at sales@vaisala.com

Ref. B210824EN-B ©Vaisala 2009
This material is subject to copyright protection, with all copyrights retained by Vaisala and its individual partners. All rights reserved. Any logos and/or product names are trademarks of Vaisala or its individual partners. The reproduction, transfer, distribution or storage of information contained in this brochure in any form without the prior written consent of Vaisala is strictly prohibited. All specifications — technical included — are subject to change without notice.



GMW116 Carbon Dioxide and Temperature Transmitter for Ventilation Control



The Vaisala CARBOCAP® Carbon Dioxide and Temperature Transmitter GMW116.

Features/Benefits

- Compact dual-parameter transmitter: measures both CO₂ and T
- Incorporates Vaisala CARBOCAP®, the silicon based NDIR sensor with unique internal referencing
- Advanced, single-beam, dual wavelength measurement with no moving parts
- Excellent long-term stability
- Ideal for ventilation control in all types of occupied spaces including those with around-the-clock occupancy
- No need for temperature compensation

The Vaisala CARBOCAP® Carbon Dioxide and Temperature Transmitter GMW116 is the compact-size transmitter that measures both carbon dioxide and temperature. The sensor is accurate and durable and it has an excellent long-term stability, which decreases maintenance.

The excellent performance of the Vaisala CARBOCAP® sensors results largely from the stable reference provided by the electrically tunable Fabry-Perot Interferometer (FPI).

In buildings with around-the-clock occupancy (e.g. hospitals, work-places, residential buildings, retirement homes), the assumed

background CO₂ level reference is simply not applicable. The true internal reference measurement of Vaisala CARBOCAP® CO₂ transmitters provides years of stable CO₂ measurements.

The GMW116 Transmitter is designed especially for demand controlled ventilation applications with CO₂ measurement range of 0 ... 2000 ppm and temperature range of 0 ... +50 °C.

With GMW116 there is no need for temperature compensation. The ideal gas temperature behaviour is taken into account automatically.

Technical Data

Performance

CO ₂ -measurement range	0 ... 2000 ppm
Temperature measurement range	0 ... +50 °C
Accuracy (including repeatability, non-linearity and calibration uncertainty)	± (2 % of range + 2 % of reading)
Long-term stability	± 5 % of range/5 years
Response time T90	1 min
Temperature dependence	compensated
Pressure dependence, typical	+0.15 % of reading/hPa
Temperature measurement accuracy	± 0.7 °C at 25 °
Warm-up time	1 min, 10 min for full specification
Product lifetime	> 10 years

Operating Environment

Temperature	0 ... +50 °C
Humidity	0 ... 85 %RH
Pressure	700 ... 1200 hPa
Electromagnetic compatibility	Complies with EMS standard EN61326-1, Generic Environment

Inputs and Outputs

Operating voltage	24 V (±20 %) AC/DC
Power consumption	< 2 W
Outputs	0 ... 10 V

Housing

Material	ABS/PC blend plastics
Weight	120 g
Cover and base colour	white RAL 9003
Fire resistance	UL94 V0
Ingress protection	IP30

Dimensions

Dimensions in mm



VAISALA

For more information, visit www.vaisala.com or contact us at sales@vaisala.com

Ref. B210872EN-A ©Vaisala 2010
This material is subject to copyright protection, with all copyrights retained by Vaisala and its individual partners. All rights reserved. Any logos and/or product names are trademarks of Vaisala or its individual partners. The reproduction, transfer, distribution or storage of information contained in this brochure in any form without the prior written consent of Vaisala is strictly prohibited. All specifications — technical included — are subject to change without notice.



GMW115 Carbon Dioxide Transmitter for Demand-controlled Ventilation



The Vaisala CARBOCAP® Carbon Dioxide Transmitter GMW115 is a wall-mounted CO₂ transmitter for demand-controlled ventilation.

Features/Benefits

- Compact, wall-mounted transmitter for demand-controlled ventilation
- Incorporates Vaisala CARBOCAP®, the silicon based NDIR sensor with unique internal referencing
- Advanced, single-beam, dual wavelength measurement with no moving parts
- Excellent long-term stability
- Ideal for ventilation control in all types of occupied spaces

Most of us spend 90 % of our time indoors. Consequently, good indoor air quality is important to our wellbeing. All human beings produce carbon dioxide gas by respiration, thus the carbon dioxide level can be used as an indicator for indoor human presence. A high CO₂ level is a sign of poor ventilation and often an indication of other unpleasant odors in the air. In many buildings the ventilation need varies throughout the day. Demand controlled ventilation is an economical way to ensure good air quality.

The Vaisala CARBOCAP® CO₂ sensors have been proven to be accurate and durable. They have an excellent long-term stability, which decreases maintenance. The superior performance of Vaisala CARBOCAP® sensors results largely

from the stable reference provided by the electrically tunable Fabry-Perot Interferometer (FPI).

The tunable FPI filter measures CO₂ absorption, and simultaneously a reference wavelength. This internal reference measurement compensates effectively for any changes in the optical path, such as light source intensity changes and contamination. In the HVAC market, this type of reference measurement is a unique feature to Vaisala CARBOCAP® products, distinguishing them from competitors' comparative products that do not have a reference measurement at all, or have an indirect reference measurement, which is based on an assumed background CO₂ levels. In buildings with around-the-clock occupancy (e.g. hospitals, work-places, residential buildings, retirement homes), the assumed background CO₂ level reference is simply not applicable. The true internal reference measurement of Vaisala CARBOCAP® CO₂ transmitters provides years of stable CO₂ measurements.

The GMW115 Transmitter is designed especially for DCV (Demand Controlled Ventilation) applications with two optional CO₂ measurement ranges of 0...2000 ppm and 0...5000 ppm.

Technical Data

Performance

CO ₂ -measurement range	0 ... 2000 ppm 0.....5000 ppm
Accuracy (including repeatability, non-linearity and calibration uncertainty)	±(2 % of range + 2 % of reading)
Long-term stability	± 5 % of range/5 years
Response time T90	1 min
Temperature dependence, typical	-0,35 % of reading / °C
Pressure dependence, typical	+0,15 % of reading/hPa
Warm-up time	1 min, 10 min for full specification
Product lifetime	> 10 years

Operating Environment

Temperature	-5 ... +45 °C (23 ... 113 °F)
Humidity	0 ... 85 %RH
Pressure	700 ... 1200 hPa
Electromagnetic compatibility	Complies with EMS standard EN61326-1, Generic Environment

Inputs and Outputs

Operating voltage	24 V (±20 %) AC/DC
Power consumption	<2 W
Outputs	4 ... 20 mA, 0 ... 10 V, RS-485, 2-wire, non-isolated

Housing

Material:	ABS plastics
Colour:	Cyclac 233599/NCS 0502-G50Y
Fire resistance:	UL94 HB
Ingress protection:	IP30

Dimensions

Dimensions in mm

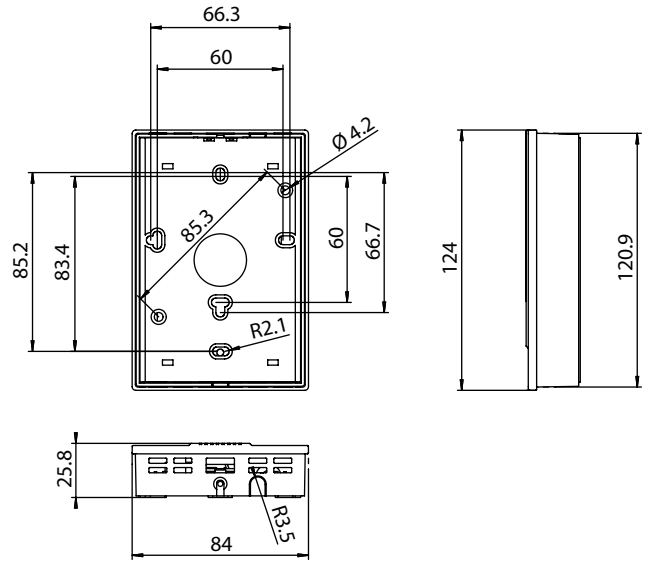

VAISALA

For more information, visit www.vaisala.com or contact us at sales@vaisala.com

Ref. B210568EN-D ©Vaisala 2009
This material is subject to copyright protection, with all copyrights retained by Vaisala and its individual partners. All rights reserved. Any logos and/or product names are trademarks of Vaisala or its individual partners. The reproduction, transfer, distribution or storage of information contained in this brochure in any form without the prior written consent of Vaisala is strictly prohibited. All specifications — technical included — are subject to change without notice.



GMD/W20 Series Carbon Dioxide Transmitters for Demand Controlled Ventilation Applications



The GMD/W20 series transmitters are designed for use in ventilation-related applications.

Features/Benefits

- Versatile transmitters
- Duct and wall mount models
- Incorporates Vaisala CARBOCAP® Sensor - the silicon-based NDIR sensor
- Excellent long-term stability
- Negligible temperature dependence
- Ease of installation

The duct mounted Vaisala CARBOCAP® Carbon Dioxide Transmitter Series GMD20 and wall mounted GMW20 are specially designed for Demand Controlled Ventilation (DCV). They are easy to install and require no maintenance. The recommended calibration interval is five years.

Vaisala CARBOCAP® Technology

The GMD/W20 Series Transmitters use the silicon-based Vaisala CARBOCAP® Sensor. The simple structure and reference measurement capabilities make this Single-Beam, Dual-Wavelength NDIR sensor extremely stable and reliable.

The temperature and flow dependences of the sensor are negligible. In addition, the measurement accuracy is not

affected by dust, water vapor and most chemicals.

Versatile Transmitters

The GMD/W20 series transmitters can be used independently, or incorporated into building energy management systems. The series consists of duct mount units GMD20/D and wall mount units GMW21/D and GMW22/D. Version D has a display. The two sizes in the wall-mount series make them easy to install for most standard junction boxes.

The duct units' compact sensor head design requires only a small hole in a ventilation duct, thereby minimizing the risk of leaking gaskets and measurement errors.

In addition to the standard 0 ... 20 mA, 4 ... 20 mA and 0 ... 10 V outputs, there are three other options: two LonWorks® interfaces and a relay output. The relay output is standard with the display units.

Improve Indoor Air at Minimal Energy Costs

The use of the GMD/W20 series transmitters ensures the best possible control of air quality and results in considerable savings in energy consumption, maintenance and recalibration costs.

Temperature Option

The GMA20T temperature module, an option with the GMW21 wall mount unit, combines both CO₂ and temperature measurement into one transmitter. The GMA20T has an output of 0 ... 10 V corresponding to a temperature range of 0 ... +50 °C (+32 ... +122 °F).

Technical Data

Performance

CARBON DIOXIDE MEASUREMENT	
Measurement range	0 ... 2000 ppm (nominal; can be calibrated for other ranges: 0 ... 5000 ppm, 0 ... 10,000 ppm, 0 ... 20,000 ppm)
Accuracy (including repeatability, non-linearity and calibration uncertainty)	± (2 % of range + 2% of reading)
Long-term stability	<±5 % of range / 5 years
Response time (63%)	1 minute
Warm-up time	1 minute, 15 minutes full specifications
TEMPERATURE MEASUREMENT (OPTIONAL WITH GMW21)	
Output signal	0 ... 10V
Corresponding measurement range	0 ... +50 °C (+32 ... +122 °F)
Accuracy at +25 °C	±0.5 °C (0.9 °F)
Warm up time	30 min
Temperature sensor	Semiconductor IC

Inputs and Outputs

Outputs	0 ... 20 or 4 ... 20 mA and 0 ... 10V
Optional outputs	relay LonWorks® interface
Resolution of analog outputs	8 bits
Recommended external load:	
current output	max. 500 ohm
voltage output	min. 1 kohm
Operating voltage	nominal 24 VAC/DC (18 ... 30 VDC)
Connections	screw terminals, wire size 0.5 ... 1.5 mm ²
Power consumption	<2.5 W

Operating Environment

Temperature	-5 ... +45 °C (+23 ... +113 °F)
Humidity	0 ... 85 %RH, non-condensing
Flow velocity (GMD20)	0 ... 10 m/s
Electromagnetic compatibility	EN61326-1, Generic Environment

Mechanics

Housing material	ABS plastic
Housing classification (GMD20 electronics housing)	IP65
Housing colour GMW21/22	NCS 0502-G50Y
Weight:	
GMD20 (D)	140 g (170 g)
GMW21 (D)	100 g (130 g)
GMW22 (D)	90 g (120 g)

Accessories and Options

Display and relay option for GMD/W21/22	GMI21
Relay output option	GMR20
LonWorks® module with CO ₂ signal (Not available when display option is added)	GML20
LonWorks® module with both CO ₂ signal and temperature signals (Not available when display option is added)	GML20T
Serial COM adapter	19040GM
Analog temperature module for GMW21 (not available when display option is added)	GMA20T
Hand-held meter for field verification	GM70

Dimensions

Dimensions in mm

GMD20 and GMD20D

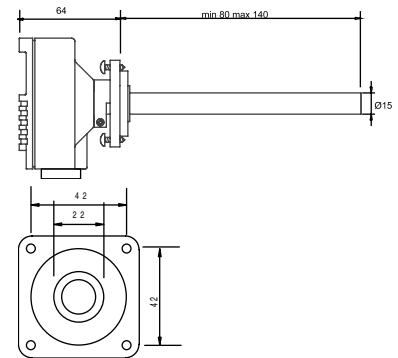

GMW21 and GMW21D

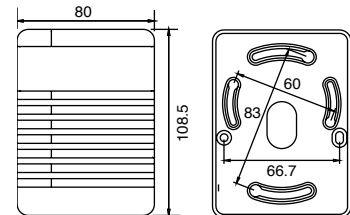

GMW22 and GMW22D

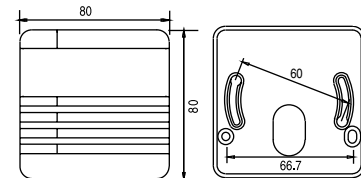

CARBOCAP® is a registered trademark of Vaisala.

VAISALA

For more information, visit
www.vaisala.com or contact
us at sales@vaisala.com

Ref. B210910EN-A ©Vaisala 2009
This material is subject to copyright protection, with all copyrights retained by Vaisala and its individual partners. All rights reserved. Any logos and/or product names are trademarks of Vaisala or its individual partners. The reproduction, transfer, distribution or storage of information contained in this brochure in any form without the prior written consent of Vaisala is strictly prohibited. All specifications — technical included — are subject to change without notice.



GMM112 Carbon Dioxide Module for HVAC Applications



The Vaisala CARBOCAP® Carbon Dioxide Module GMM112 is a basic CO₂ measurement module.

Most of us spend 90% of our time indoors. Consequently, good indoor air quality is important to our wellbeing. All human beings produce carbon dioxide gas by respiration, thus the carbon dioxide level can be used as an indicator for indoor human presence. A high CO₂ level is a sign of poor ventilation and often an indication of other unpleasant odors in the air. In many buildings the ventilation need varies throughout the day. Demand controlled ventilation is an economical way to ensure good air quality.

The Vaisala CARBOCAP® CO₂ sensors have been proven to be accurate and durable. They have an excellent long-term stability, which decreases maintenance. The

superior performance of Vaisala CARBOCAP® sensors results largely from the stable reference provided by the electrically tunable Fabry-Perot Interferometer (FPI).

The tunable FPI filter measures CO₂ absorption, and simultaneously a reference wavelength. This internal reference measurement compensates effectively for any changes in the optical path, such as light source intensity changes and contamination. In the HVAC market, this type of reference measurement is a unique feature to Vaisala CARBOCAP® products, distinguishing them from competitors' comparative products that do not have a reference measurement at all, or have an indirect reference measurement,

Features/Benefits

- Compact, OEM module for demand-controlled ventilation and other CO₂ measurement applications
- Incorporates Vaisala CARBOCAP®, the silicon based NDIR sensor with unique internal referencing
- Advanced, single-beam, dual wavelength measurement with no moving parts
- Excellent long-term stability
- Ideal for ventilation control in all types of occupied spaces

which is based on an assumed background CO₂ levels. In buildings with around-the-clock occupancy (e.g. hospitals, work-places, residential buildings, retirement homes), the assumed background CO₂ level reference is simply not applicable. The true internal reference measurement of Vaisala CARBOCAP® CO₂ transmitters provides years of stable CO₂ measurements.

The GMM112 Carbon Dioxide Module is designed especially for DCV (Demand Controlled Ventilation) applications with three optional CO₂ measurement ranges of 0...2000 ppm, 0...5000 ppm and 0...10000 ppm.

Technical Data

Performance

CO ₂ -measurement range	0 ... 2000 ppm 0 ... 5000 ppm 0 ... 10000 ppm
Accuracy (including repeatability, non-linearity and calibration uncertainty)	± (2 % of range + 2 % of reading)
Long-term stability	± 5 % of range/5 years
Response time T90	1 min
Temperature dependence, typical	-0,35 % of reading / °C
Pressure dependence, typical	+0,15 % of reading/hPa
Warm-up time	1 min, 10 min for full specification
Product lifetime	> 10 years

Operating Environment

Temperature	-5 ... +45 °C (23 ... 113 °F)
Humidity	0 ... 85 %RH
Pressure	700 ... 1200 hPa
Electromagnetic compatibility	Complies with EMS standard EN61326-1:1997 + Am1:1998, Generic Environment

Inputs and Outputs

Operating voltage	24 V (±20 %) AC/DC
Power consumption	<2 W
Outputs	4 ... 20 mA, 0 ... 10 V, RS-485, 2-wire, non-isolated

Dimensions

Dimensions in mm

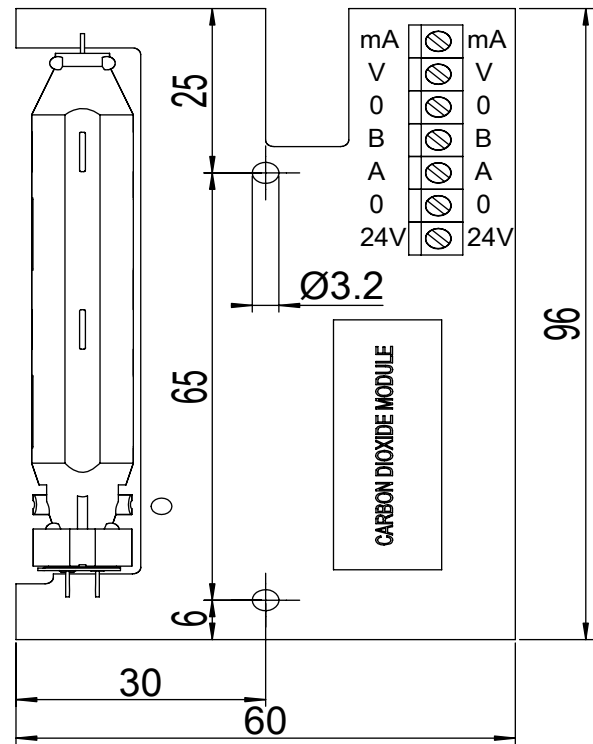

VAISALA

For more information, visit www.vaisala.com or contact us at sales@vaisala.com

Ref. B210567EN-D ©Vaisala 2009

This material is subject to copyright protection, with all copyrights retained by Vaisala and its individual partners. All rights reserved. Any logos and/or product names are trademarks of Vaisala or its individual partners. The reproduction, transfer, distribution or storage of information contained in this brochure in any form without the prior written consent of Vaisala is strictly prohibited. All specifications – technical included – are subject to change without notice.



GMM20W Carbon Dioxide Module for OEM Applications



Features/Benefits

- Incorporates the silicon based Vaisala CARBOCAP® Sensor
- Stable in terms of time and temperature
- Dust, water vapor or most chemicals do not affect the measurement accuracy of the sensor
- Small size enables easy integration into various systems

The Vaisala CARBOCAP® Carbon Dioxide Module GMM20W is designed for OEM applications in benign environments.

Technical Data

Performance

CARBON DIOXIDE MEASUREMENT

Measurement range	0 ... 2000 ppm (nominal; can be calibrated for other ranges: 0 ... 5000 ppm, 0 ... 10,000 ppm, 0 ... 20,000 ppm)
Accuracy (including repeatability, non-linearity and calibration uncertainty)	\pm (2 % of range + 2% of reading)
Long-term stability	\leq 5 % of range / 5 years
Response time (63%)	1 minute
Warm-up time	minute, 15 minutes full specifications
Weight	45 g

Inputs and Outputs

Outputs	0 ... 20 or 4 ... 20 mA and 0 ... 10 V
Resolution of analog outputs	8 bits
current output	max. 500 ohm
voltage output	min. 1 kohm
Operating voltage	nominal 24 VAC/DC (18 ... 30 VDC)
Power consumption	$<$ 2.5 W

Operating Environment

Temperature	-5 ... +45 °C (+23 ... +113 °F)
Humidity	0 ... 85 %RH, non-condensing
Electromagnetic compatibility	EN61326-1, Generic Environment

Accessories and Options

Display and relay option	GMI21
Relay output option	GMR20
Calibration software kit (disk and serial COM adapter)	19222GM
Analog temperature module* (not available when display option is added)	GMA20T

Dimensions

Dimensions in mm

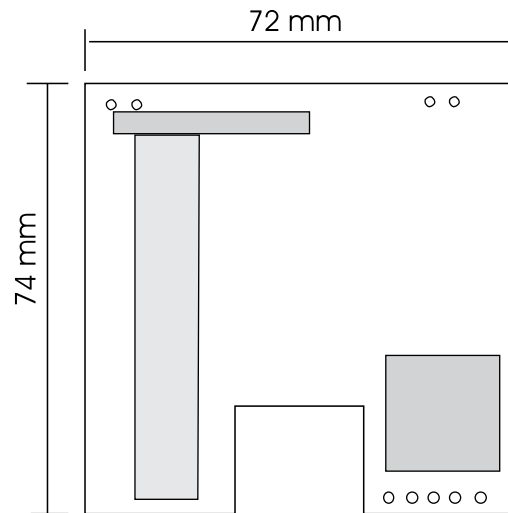

CARBOCAP® is a registered trademark of Vaisala.

VAISALA

For more information, visit
www.vaisala.com or contact
us at sales@vaisala.com

Ref. B210939EN-A ©Vaisala 2010
This material is subject to copyright protection, with all
copyrights retained by Vaisala and its individual partners. All
rights reserved. Any logos and/or product names are trademarks
of Vaisala or its individual partners. The reproduction, transfer,
distribution or storage of information contained in this brochure
in any form without the prior written consent of Vaisala is strictly
prohibited. All specifications — technical included — are subject
to change without notice.



PTU300 Combined Pressure, Humidity and Temperature Transmitter for Demanding Applications



The Vaisala PTU300 Combined Pressure, Humidity and Temperature Transmitter is a versatile, multi-purpose instrument.

One Transmitter, Three Measurements

The Vaisala Combined Pressure, Humidity and Temperature

Features/Benefits

- Barometric pressure, humidity and temperature measurement in one transmitter
- Available with two barometric pressure sensors – added reliability
- RS-232C serial interface with NMEA protocol for GPS use
- Optional display, RS-485, analog output, and relay
- Optional power supply module
- NIST traceable calibration
- HMT330MIK Installation kit for outdoor use
- Applications include environmental monitoring in calibration laboratories, GPS meteorology: estimating precipitable water vapor in the atmosphere; weather stations
- Modbus protocol support (RTU/TCP)

Transmitter PTU300 measures barometric pressure in two accuracy classes, humidity, and temperature.

You can choose which probe best suits your needs: PTU301 for laboratories, PTU303 for outdoor use, the warmed PTU307 probe for demanding meteorology, and PTU30T for pressure and temperature only.

Vaisala Proven Sensor Technology

The PTU300 transmitter uses sensors known for their high accuracy and excellent long-term stability: the Vaisala BAROCAP® is used for pressure measurement and the Vaisala HUMICAP® for humidity measurement. The temperature sensor is a platinum RTD sensor.

Graphical Trend Display

The PTU300 series features a large numerical and graphical display, allowing users to easily monitor operational data, measurement trends and 1-year measurement history. The optional data logger with real-time clock makes it possible to generate

over four years of measured history, and zoom in on any desired time or time frame. The battery backup of the real-time clock guarantees a reliable logging of measured data.

The display alarm allows tracking of any measured parameter, with a freely configurable low and high limit.

Data Collection and (Wireless) Transfer to PC

The recorded measurement data can be viewed on the display or transferred to a PC with Microsoft Windows® software. The transmitter can also be connected to a network with an optional (W)LAN interface, which enables a (wireless) Ethernet connection.

A USB-RJ45 cable makes it easy to connect the service port of the PTU300 to a PC. PTU300 is also capable in applying the MODBUS communication protocol and together with an appropriate connection option provides either MODBUS RTU (RS485) or MODBUS TCP/IP (Ethernet) communication.

Flexible Calibration

A quick, one-point field calibration for humidity can easily be done using the Vaisala Hand-Held Humidity Meter HM70.

Serial Communication

The PTU300 comes with a standard RS-232 serial interface. The output format is compatible with major GPS receivers and NMEA coded messages. RS-485 is available as an option.

Outdoor Installation Kit

The optional HMT330MIK Installation Kit is available for outdoor installation. It provides reliable measurements for meteorological purposes.

PTU300 Models



PTU301 for wall mounting

Dimensions

Dimensions in mm (inches)

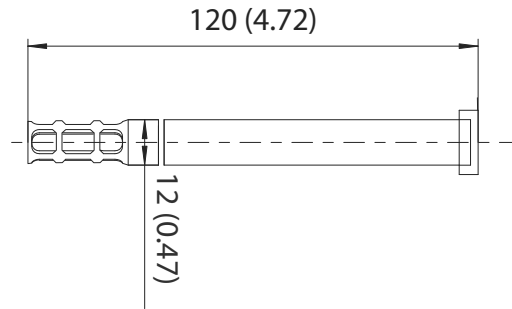

PTU301 short cable probe

Dimensions

Dimensions in mm (inches)

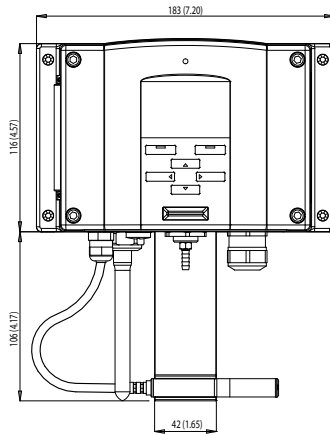

PTU303 for outdoor use

Dimensions

Dimensions in mm (inches)

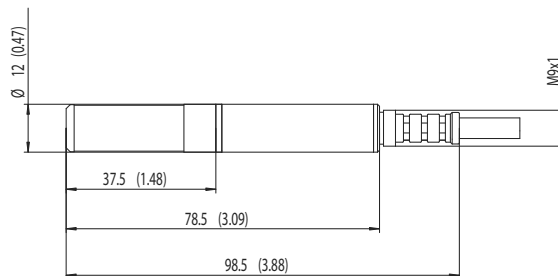

PTU300 Models



PTU307 warmed probe for demanding meteorological installations

Dimensions

Dimensions in mm (inches)

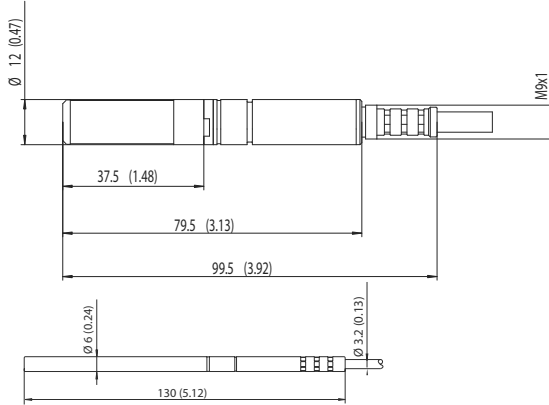

PTU30T for pressure and temperature only measurement

Dimensions

Dimensions in mm (inches)

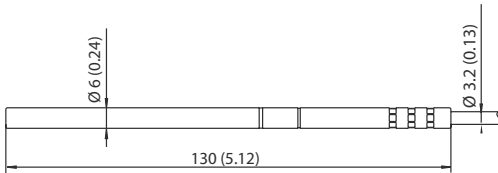

Technical Data

Performance

BAROMETRIC PRESSURE

Pressure range	500 ... 1100 hPa, 50 ... 1100 hPa		
Accuracy	500 ... 1100 hPa	500 ... 1100 hPa	50 ... 1100 hPa
	CLASS A	CLASS B	
Linearity	±0.05 hPa	±0.10 hPa	±0.20 hPa
Hysteresis*	±0.03 hPa	±0.03 hPa	±0.08 hPa
Repeatability*	±0.03 hPa	±0.03 hPa	±0.08 hPa
Calibration uncertainty**	±0.07 hPa	±0.15 hPa	±0.20 hPa
Accuracy at +20 °C***	±0.10 hPa	±0.20 hPa	±0.30 hPa
Temperature dependence****	±0.1 hPa	±0.1 hPa	±0.3 hPa
Total accuracy (-40 ... +60 °C / -40 ... +140 °F)	±0.15 hPa	±0.25 hPa	±0.45 hPa
Long-term stability/year	±0.1 hPa	±0.1 hPa	±0.2 hPa
Response time (100 % response)			
one sensor	2 s	1 s	1 s
Pressure units	hPa, mbar, kPa, Pa, inHg, mmH20, mmHg, torr, psia		

* Defined as ±2 standard deviation limits of endpoint non-linearity, hysteresis error or repeatability error and calibration.

** Defined as ±2 standard deviation limits of accuracy of the working standard including traceability to NIST.

*** Defined as the root sum of the squares (RSS) of endpoint non-linearity, hysteresis error, repeatability error and calibration uncertainty at room temperature.

**** Defined as ±2 standard deviation limits of temperature dependence over the operating temperature range.

RELATIVE HUMIDITY

Measurement range	0 ... 100 % RH	
Accuracy (including non-linearity, hysteresis, and repeatability at +15 ... +25 °C)	±1 %RH (0 ... 90 % RH) ±1.7 %RH (90 ... 100 %RH)	
at -20 ... +40 °C	±(1.0 + 0.008 x reading) %RH	
at -40 ... +60 °C	±(1.5 + 0.015 x reading) %RH	
Factory calibration uncertainty (+20 °C)		
(Defined as ±2 standard deviation limits. Small variations possible, see also calibration certificate.)	± 0.6 % RH (0 ... 40 %RH) ± 1.0 % RH (40 ... 97 %RH)	

Sensor

for typical applications Vaisala HUMICAP® 180 or 180R*
for applications with chemical purge/warmed probe Vaisala HUMICAP® 180C or 180RC*

Response time (90 %) at +20 °C (+68 °F) in still air	
with grid filter	8 s / 17 s*
with grid + steel netting filter	20 s / 50 s*
with sintered filter	40 s / 60 s*

* with HUMICAP® 180R or 180RC sensor

TEMPERATURE

Measurement range, all probes	-40 ... +60 °C (-40 ... +140 °F)
Accuracy at +20 °C (+68 °F)	± 0.2 °C (± 0.4 °F)
Temperature units	°C, °F



The display also shows the WMO pressure trend ΔP 3h and tendency of 0 ... 9.

ACCURACY OVER TEMPERATURE RANGE

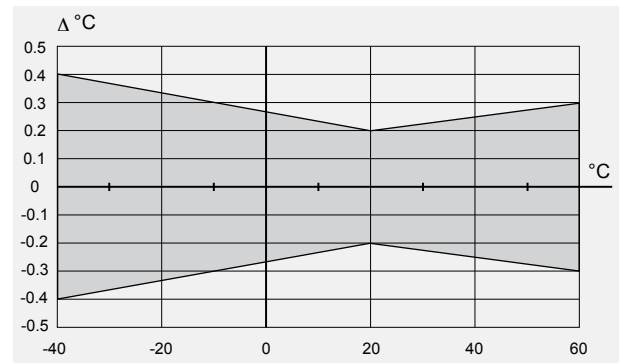

Temperature sensor

PT100 RTD 1/3 Class B IEC 751

Operating Environment

Operating temperature	-40 ... +60 °C (-40 ... +140 °F)
with display	0 ... +60 °C (+32 ... +140 °F)
Humidity range	non-condensing
Electromagnetic compatibility	EN61326-1:1997 + Am1:1998 +Am2:2001; Industrial Environment

Inputs and Outputs

Operating voltage	10 ... 35 VDC, 24 VAC
with optional power supply module	100 ... 240 VAC, 50/60 Hz
Power consumption at +20 °C (U_{in} 24 VDC)	
RS-232	max. 28 mA
U_{out} 3 x 0 ... 1 V/0 ... 5 V/0 ... 10 V	max. 33 mA
I_{out} 3 x 0 ... 20 mA	max. 63 mA
display and backlight	+20 mA
during chemical purge	max. +110 mA
during probe heating	+120 mA
Settling time at power-up (one sensor)	
class A	4 s
class B	3 s
External loads	
current outputs	$R_L < 500 \text{ ohm}$
0 ... 1 V output	$R_L > 2 \text{ kohm}$
0 ... 5 V and 0 ... 10 V outputs	$R_L > 10 \text{ kohm}$

Recommended wire size	0.5 mm ² (AWG 20) stranded wires	
Digital outputs	RS-232, RS-485 (optional)	
Protocols	ASCII commands, MODBUS RTU	
Service connection	RS-232, USB	
Relay outputs (optional)	0.5 A, 250 VAC	
Ethernet interface (optional)		
Supported standards	10BASE-T, 100BASE-TX	
Connector	8P8C (RJ45)	
IPv4 address assignment	DHCP (automatic), static	
Protocols	Telnet, MODBUS TCP/IP	
WLAN interface (optional)		
Supported standards	802.11b	
Antenna connector type	RP-SMA	
IPv4 address assignment	DHCP (automatic), static	
Protocols	Telnet, MODBUS TCP/IP	
Security	WEP 64/128, WPA2	
Authentication / Encryption (WLAN)		
Open / no encryption		
Open / WEP		
WPA Pre shared key / TKIP		
WPA Pre shared key / CCMP (a.k.a. WPA2)		
Optional data logger with real-time clock		
Logged parameters	max. four with trend/min/max values	
Logging interval	10 sec (fixed)	
Max. logging period	4 years 5 months	
Logged points	13.7 million points per parameter	
Battery lifetime	min. 5 years	
Display	LCD with backlight, graphic trend display of any parameter	
Menu languages	English, Finnish, French, German, Japanese, Chinese, Spanish, Swedish, Russian	
Analog outputs (optional)		
current output	0 ... 20 mA, 4 ... 20 mA	
voltage output	0 ... 1 V, 0 ... 5 V, 0 ... 10 V	
Humidity and temperature		
accuracy at +20 °C	±0.05% full scale	
temperature dependence	±0.005%/°C full scale	
Pressure	500 ... 1100 hPa	50 ... 1100 hPa
accuracy at +20 °C	±0.30 hPa	±0.40 hPa
accuracy at -40 ... +60 °C	±0.60 hPa	±0.75 hPa

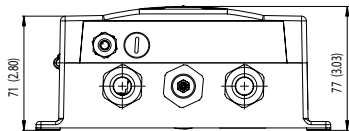

Mechanics

Cable bushing	M20 x 1.5 for cable diameter
	8 ... 11 mm/0.31 ... 0.43"
Conduit fitting	1/2" NPT
User cable connector (optional)	M12 series 8-pin (male)
option 1	female plug with 5 m (16.4 ft) black cable
option 2	female plug with screw terminals
Probe cable diameter	
PTU303	6.0 mm
other probes	5.5 mm
Housing material	G-AISI 10 Mg (DIN 1725)
Housing classification	IP 65 (NEMA 4)
Weight	
depending on selected probe	1.5 ... 2.0 Kg

Accessories

PC software and cable	215005
USB-RJ45 Serial Connection Cable	219685
Connection cable for HM70	211339
Wall mounting plate (plastic)	214829
Pole installation kit	215108
Rain shield	215109
DIN rail installation set	211477
Duct installation kit, PTU303/307	210697
Cable gland and AGRO, PTU303/307	HMP247CG
Solar radiation shield, PTU303/307/30T	DTR502B
Meteorological installation kit	HMT330MIK
Duct installation kit (T probe)	215003

Dimensions

Dimensions in mm (inches)

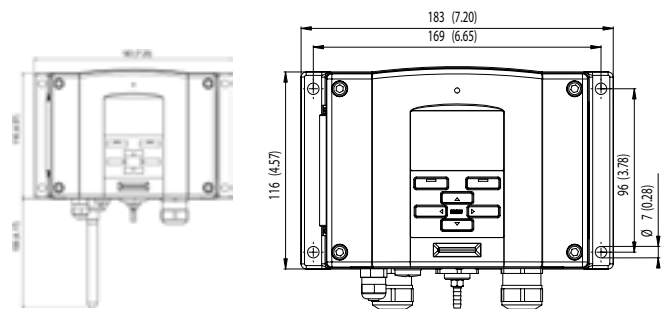

BAROCAP® and HUMICAP® are registered trademarks of Vaisala.



TYPE APPROVED PRODUCT
CERTIFICATE NO.: A-11440

VAISALA

For more information, visit www.vaisala.com or contact us at sales@vaisala.com

Ref. B210954EN-C ©Vaisala 2011
This material is subject to copyright protection, with all copyrights retained by Vaisala and its individual partners. All rights reserved. Any logos and/or product names are trademarks of Vaisala or its individual partners. The reproduction, transfer, distribution or storage of information contained in this brochure in any form without the prior written consent of Vaisala is strictly prohibited. All specifications — technical included — are subject to change without notice.



MEASURE MONITOR AND VALIDATE IN CONTROLLED ENVIRONMENTS

HUMIDITY - TEMPERATURE
- CO₂ - dP - AND MORE ...

Watch a brief online video about
Vaisala Veriteq Continuous
Monitoring System.
www.vaisala.com/cms



www.vaisala.com/lifescience-hitech

sales@vaisala.com

VAISALA

PTB330 Digital Barometer for Professional Meteorology, Aviation, and Industrial Users



Vaisala BAROCAP® Digital Barometer PTB330 with a new trend display.

Vaisala BAROCAP® Digital Barometer PTB330 is a new generation barometer, designed for a wide range of high-end atmospheric pressure measurement. The pressure measurement of the PTB330 is based on the Vaisala in-house, silicon

Features/Benefits

- Vaisala BAROCAP® sensor
- Accurate measurement
- Excellent long-term stability
- Added reliability through redundancy
- Graphical trend display with 1-year history data
- Height and altitude corrected pressure (QFE, QNH)
- For professional meteorology and aviation, laboratories, demanding industrial applications

capacitive, absolute pressure sensor - the Vaisala BAROCAP® Sensor. It provides high measurement accuracy and excellent long-term stability.

Highly Accurate

The PTB330 series is highly accurate. The Class A barometers for the most demanding applications are fine-tuned and calibrated against a high-precision pressure calibrator. Class B barometers are adjusted and calibrated using electronic working standard. All the PTB330 barometers come with a NIST traceable, factory calibration certificate.

Reliability Through Redundancy

According to customers' choice, the PTB330 can incorporate one, two or three BAROCAP® sensors. When two or three sensors are used, the barometer continuously compares the readings of the pressure sensors

against one another and provides information on whether these are within the set internal difference criteria. This unique feature provides redundancy in pressure measurement.

Thus, users also get a stable and reliable pressure reading at all times as well as a pre-indication of when to service or recalibrate the barometer.

QNH and QFE

The PTB330 can be set to compensate for QNH and QFE pressure used especially in aviation. The QNH represents the pressure reduced to sea level, based on the altitude and temperature of the observation site. The QFE represents the height corrected pressure of small differences in altitude, for example, the air pressure at the airfield elevation.

Graphical Display

The PTB330 features a multi-lingual, graphical display allowing users to monitor measurement trends. The graph is updated automatically while measuring and it provides a one-year measurement history. In addition to instant pressure, the PTB330 also provides the WMO pressure trend and tendency codes.

Applications

The PTB330 can be used successfully for aviation, professional meteorology, and for demanding industrial pressure measurement applications such as accurate laser interferometric measurement and exhaust gas analysis in engine test benches.

Technical Data

Performance

BAROMETRIC PRESSURE RANGE 500 ... 1100 hPa		
	Class A	Class B
Linearity*	±0.05 hPa	±0.10 hPa
Hysteresis*	±0.03 hPa	±0.03 hPa
Repeatability*	±0.03 hPa	±0.03 hPa
Calibration uncertainty**	±0.07 hPa	±0.15 hPa
Accuracy at +20 °C (+68 °F) ***	±0.10 hPa	±0.20 hPa

BAROMETRIC PRESSURE RANGE 50 ... 1100 hPa		
	Class A	Class B
Linearity*		±0.20 hPa
Hysteresis*		±0.08 hPa
Repeatability*		±0.08 hPa
Calibration uncertainty**		±0.15 hPa
Accuracy at +20 °C ***		±0.20 hPa

TEMPERATURE DEPENDENCE****		
500 ... 1100 hPa		±0.1 hPa
50 ... 1100 hPa		±0.3 hPa

TOTAL ACCURACY -40 ... +60 °C (-40 ... +140 °F)		
	Class A	Class B
500 ... 1100 hPa	±0.15 hPa	±0.25 hPa
50 ... 1100 hPa		±0.45 hPa

LONG-TERM STABILITY		
500 ... 1100 hPa		±0.1 hPa/year
50 ... 1100 hPa		±0.1 hPa/year

* Defined as ±2 standard deviation limits of endpoint non-linearity, hysteresis or repeatability error.

** Defined as ±2 standard deviation limits of inaccuracy of the working standard including traceability to NIST.

*** Defined as the root sum of the squares (RSS) of endpoint non-linearity, hysteresis error, repeatability error and calibration uncertainty at room temperature.

**** Defined as ±2 standard deviation limits of temperature dependence over the operating temperature range.

Operating Environment

Pressure range	500 ... 1100 hPa, 50 ... 1100 hPa
Temperature range	
operating	-40 ... +60 °C (-40 ... +140 °F)
with local display	0 ... +60 °C (+32 ... +140 °F)

Data Transfer Software

MI70 Link Interface Software	
Requirement:	Microsoft® Windows OS Microsoft® Excel

Inputs and Outputs

Supply voltage	10 ... 35 VDC
Supply voltage sensitivity	negligible
Typical power consumption at +20 °C (U _{in} 24 VDC, one pressure sensor)	
RS-232	25 mA
RS-485	40 mA
U _{out}	25 mA
I _{out}	40 mA
display and backlight	+20 mA
Serial I/O	RS232C, RS485/422
Pressure units	hPa, mbar, kPa, Pa inHg, mmH ₂ O, mmHg, torr, psia
Resolution	Class A 0.01 hPa Class B 0.1 hPa
Settling time at power-up (one sensor)	4 s 3 s
Response time (one sensor)	2 s 1 s
Acceleration sensitivity	negligible
Pressure connector	M5 (10-32) internal thread
Pressure fitting	barbed fitting for 1/8" I.D. tubing or quick connector with shutoff valve for 1/8" hose
Maximum pressure limit	5000 hPa abs.
Compliance	EMC standard EN61326-1:1997 + Am1:1998 + Am2:2001: Industrial Environment

Mechanics

Housing material	G AlSi10 Mg (DIN 1725)
Housing classification	IP65 (NEMA4)
Weight	1 - 1.5 kg

Analog Output (optional)

Current output	0 ... 20 mA, 4 ... 20 mA
Voltage output	0 ... 1 V, 0 ... 5 V, 0 ... 10 V
Accuracy at pressure range	500 ... 1100 hPa 50 ... 1100 hPa
at +20 °C	±0.30 hPa ±0.40 hPa
at -40 ... +60 °C	±0.60 hPa ±0.75 hPa

Accessories

Serial interface cable	19446ZZ
USB-RJ45 serial connection cable	219685
Software interface kit	215005
Wall mounting kit	214829
Outdoor installation kit (weather shield)	215109
Installation kit for pole or pipeline	215108
Power supply module	POWER-1
Temperature compensated analog output module	AOUT-1T
Isolated RS-485 module	RS485-1

VAISALA

For more information, visit
www.vaisala.com or contact
us at sales@vaisala.com

Ref. B210708EN-C ©Vaisala 2011
This material is subject to copyright protection, with all copyrights retained by Vaisala and its individual partners. All rights reserved. Any logos and/or product names are trademarks of Vaisala or its individual partners. The reproduction, transfer, distribution or storage of information contained in this brochure in any form without the prior written consent of Vaisala is strictly prohibited. All specifications — technical included — are subject to change without notice.



Take the Lab to the Field

Vaisala Barometric Pressure Transfer Standard PTB330TS



PTB330TS transport case

Operational PTB330TS unit includes a PTB330 digital barometer, hand-held MI70 indicator, optional HMP155 humidity and temperature probe, optional MI70 Link PC software, a user's guide and a weatherproof transfer case equipped with a shoulder strap.

Barometric Pressure Transfer Standard PTB330TS makes field inspection accurate and easy. It combines a PTB330 digital barometer with a hand-held MI70 indicator within a portable unit functioning as a transfer standard. The optional HMP155 probe is available for

accurate humidity and temperature measurement.

The PTB330TS is suitable for various reference measurements in industrial and meteorological areas.

The PTB330TS comes in a durable and weatherproof transport case that can be easily carried and

shipped. The components are placed in a proofing foam interior, with accessories and user's guide placed in the lid organizer. The case includes a separate inner tabletop case in which the barometer is mounted. Shoulder strap is included for convenience. Battery duration is up to 11 hours of continuous use and up to 30 days in data logging use.

Features / Benefits

- Portable, battery operated transfer standard with data logging capability
- Barometric pressure with Vaisala BAROCAP® Digital Barometer PTB330
 - Excellent long term stability
 - Accurate measurements
 - Added reliability through redundancy
- Optional humidity and temperature measurements with HMP155
 - Vaisala HUMICAP®180R sensor
 - superior long-term stability
 - New, fast temperature probe
 - Chemical purge
- Multilingual user interface, nine languages
- Data can be logged, and transferred to a PC via MI70 Link software
- SO/IEC 17025 Accredited calibration services available
- For professional meteorology, aviation, laboratories and demanding industrial applications



The PTB330 Digital Barometer

PTB330 Digital Barometer

Vaisala BAROCAP® Digital Barometer PTB330 is a new generation barometer designed for a wide range of high-end atmospheric pressure measurement. The pressure measurement of the PTB330 is based on the Vaisala in-house, silicon capacitive, absolute pressure sensor – the Vaisala BAROCAP® Sensor. It provides high measurement accuracy and excellent long-term stability.

High Accuracy

The PTB330 series features extremely high accuracy. Class A barometers for the most demanding applications are fine-adjusted and calibrated against a high-precision pressure calibrator. All the PTB330 barometers come with a NIST traceable, factory calibration certificate, also optional ISO/IEC 17025 accreditation calibration services are available.

Reliability through Redundancy

According to customers' choice, the PTB330 can incorporate one, two or three BAROCAP® sensors. When two or three sensors are used, the barometer continuously compares the readings of the pressure sensors against one another and provides



The HMP155 probe

information on whether these are within the set internal difference criteria. This unique feature provides redundancy in pressure measurement. Thus, users get a stable and reliable pressure reading at all times as well as a pre-indication of when to service or re-calibrate the barometer.

Optional HMP155 Humidity and Temperature Probe

The new Vaisala HUMICAP® Humidity and Temperature Probe HMP155 provides reliable humidity and temperature measurement.

Long-Term Stability

The HMP155 has a new generation Vaisala HUMICAP®180R sensor that has excellent stability and withstands harsh environments well. The probe structure is solid and the sensor is protected with a sintered teflon filter, which gives maximum protection against liquid water, dust, and dirt.

Fast Temperature Measurement

What's more, with its fast response time, the additional temperature probe for the HMP155 is ideal for measurement in environments with rapidly changing temperatures.



The MI70 hand-held indicator displaying the prevailing pressure in hPa

MI70 Hand-Held Indicator for Spot-Checking Applications

The Vaisala Measurement Indicator MI70 is a user-friendly indicator for demanding spot-checking measurements. It is ideal for field checking and calibration of Vaisala's fixed instruments.

Easy-to-Use User Interface and Three-Variable Display

The MI70 features a multilingual, menu-based user interface, and a clear graphical LCD display. Overall three measurement parameters can be displayed and logged into the meter's memory at the same time. One or two probes or transmitters can be connected simultaneously.

MI70 Link

The optional MI70 Link Windows® software and the USB connection cable form a practical tool for transferring logged data and real time measurement data from the MI70 to a PC.



For more information, visit www.vaisala.com or contact us at sales@vaisala.com

Ref. B210785EN-B ©Vaisala 2011
This material is subject to copyright protection, with all copyrights retained by Vaisala and its individual partners. All rights reserved. Any logos and/or product names are trademarks of Vaisala or its individual partners. The reproduction, transfer, distribution or storage of information contained in this brochure in any form without the prior written consent of Vaisala is strictly prohibited. All specifications – technical included – are subject to change without notice.



Vaisala Barometric Pressure Transfer Standard PTB330TS

Technical Data

These specifications apply when MI70, PTB330 and HMP155 are used together in the PTB330TS product. For individual specifications, please refer to the product documentation and brochures of the PTB330 and HMP155.

General

Operating temperature range	-10 ... +40 °C (+14 ... +104 °F)
Operating humidity range	non-condensing
Maximum pressure limit	5000 hPa abs.
Power supply	Rechargeable NiMH battery pack with AC-adaptor or 4xAA-size alkalines, type IEC LR6
Operation time (using rechargeable battery pack)	
Continuous use with PTB330	11 h typical at +20 °C (+68 °F)
Datalogging use	up to 30 days
Menu languages	English, Chinese, French, Spanish, German, Russian, Japanese, Swedish, Finnish
Display	LCD with backlight, graphic trend display of any parameter, character height up to 16 mm
Data logging capacity	2700 points
Alarm	audible alarm function

PTB330TS is in conformity with the following EU directives:
 - EMC Directive (2004/108/EC) Complies with the EMC product family standard EN61326-1, Electrical equipment for measurement control and laboratory use - Basic immunity test requirements.
 - Low Voltage Directive (2006/95/EC)
 - ROHS Directive (2002/95/EC)

Performance

Barometric Pressure (PTB330)

Measurement range	500 ... 1100 hPa
Linearity*	±0.05 hPa
Hysteresis*	±0.03 hPa
Repeatability*	±0.03 hPa
Calibration uncertainty**	±0.07 hPa
Accuracy at +20 °C (+68 °F) ***	±0.10 hPa
Temperature dependence****	±0.1 hPa
Total accuracy -40... +60 °C (-40...+140 °F)	±0.15 hPa
Long-term stability	±0.1 hPa/year
Settling time at power-up (one sensor)	4 s
Response time (one sensor)	2 s
Acceleration sensitivity	negligible

* Defined as ±2 standard deviation limits of endpoint nonlinearity, hysteresis or repeatability error.
 ** Defined as ±2 standard deviation limits of inaccuracy of the working standard including traceability to NIST.
 *** Defined as the root sum of the squares (RSS) of endpoint non-linearity, hysteresis error, repeatability error and calibration uncertainty at room temperature.
 **** Defined as ±2 standard deviation limits of temperature dependence over the operating temperature range.



Relative Humidity (HMP155)

Measurement range	0 ... 100 %RH
Accuracy (incl. non-linearity, hysteresis and repeatability) at +15 ... +25 °C (+59 ... +77 °F)	±1.7 %RH (90 ... 100 %RH) ±1.0 %RH (0 ... 90 %RH)
-10 ... +40 °C (-4 ... 104 °F)	±(1.0 + 0.008 x reading) %RH
Factory calibration uncertainty (+20 °C /+68 °F)	±0.6 %RH (0 ... 40 %RH)* ±1.0 %RH (40 ... 97 %RH)*
Humidity sensor	HUMICAP180R HUMICAP180RC

Response time at +20 °C in still air with a sintered PTFE filter	
63 %	20 s
90 %	60 s

* Defined as ±2 standard deviation limits. Small variations possible, see also calibration certificate.

Temperature (HMP155)

Measurement range	-10 ... +40 °C (+14 ... +104 °F)
Accuracy	
-10 ... +20 °C	±(0.176 - 0.0028 x temperature) °C
+20 ... +40 °C	±(0.07 + 0.0025 x temperature) °C

Accuracy over temperature range (see graph overleaf)

Temperature sensor Pt100 RTD 1/3 Class B IEC 751

Response time with additional temperature probe in 3 m/s air flow	
63 %	<20 s
90 %	<35 s

Technical Data

Available Parameters

Pressure parameters	P, P3h, HCP, QFE, QNH
Humidity and temperature parameters	RH, T, Tdf, Td, x, Tw

Inputs and Outputs

MI70 probe ports	2
MI70 data interface	RS-232 (accessible only with MI70 Link software)
PTB330 supply voltage	10 ... 35 VDC (if not powered by MI70)
PTB330 data interface	RS-232C
PTB330 serial I/O connectors	RJ45 (service port) Male 8-pin M12 (user port)
HMP155 data interface	RS-485
HMP155 serial I/O connector	Male 8-pin M12

Mechanics

PTB330	
Housing material	G-AISI 10 Mg (DIN 1725)
Housing classification	IP65
Pressure connector	M5 (10-32) internal thread
Pressure fitting	barbed fitting for 1/8" I.D. tubing or quick connector with shutoff valve for 1/8" hose
HMP155	
Housing material	PC
Housing classification	IP66
Additional T-probe cable length	2 m
Cable material	PUR
Sensor protection	Sintered PTFE
MI70 MEASUREMENT INDICATOR	
Housing classification	IP54
Housing material	ABS/PC blend
TRANSPORT CASE	
Housing classification (when closed)	IP67
Plastic parts	TTX01®, PP+SEBS, POM
Metal parts	stainless steel AISI303
Interior foam material	PE and polyether
Weight with all instruments and typical accessories	5.9 kg
Exterior dimensions (LxWxH)	405x330x165 mm (15.94x12.99x6.50) inch

Accessories

PTB330	
MI70 – PTB330 Spiral Cable	223235SP
USB-RJ45 serial connection cable	219685
Serial connection cable	19446ZZ
Barbed fitting 1/8"	19498SP
Quick Connector 1/8"	220186
Transport case with interior foams and tabletop casing for PTB330	224068SP
Tabletop casing for PTB330	224064SP
MI70	
USB cable for MI70, includes MI70 Link software	219687
MI70 Link software	MI70LINK
MI70 connection cable to HMT330, MMT330, DMT340, HMT100, PTB330	211339
MI70 battery pack	26755
variety of AC adapters available	
HMP155	
HMP155 – MI70 connection cable	221801
Protection set for HMP155 calibration buttons: protective cover, 2 O-rings and protective plug	221318
USB cable for HMP155	221040
Sintered teflon filter + O-ring	219452SP
Humidity sensor	HUMICAP180R
Humidity Calibrator	HMK15

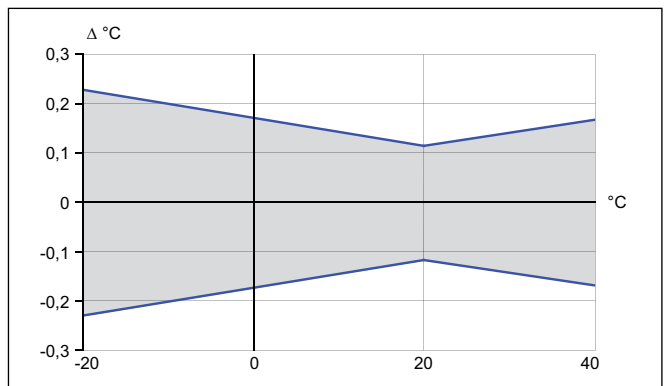

Accuracy of HMP155 temperature measurement over temperature range



For more information, visit www.vaisala.com or contact us at sales@vaisala.com

Ref. B210786EN-A ©Vaisala 2009
This material is subject to copyright protection, with all copyrights retained by Vaisala and its individual partners. All rights reserved. Any logos and/or product names are trademarks of Vaisala or its individual partners. The reproduction, transfer, distribution or storage of information contained in this brochure in any form without the prior written consent of Vaisala is strictly prohibited. All specifications – technical included – are subject to change without notice.



PTB210 Digital Barometer



The PTB210 paired with the SPH10 Static Pressure Head.

The Vaisala BAROCAP® Digital Barometer PTB210 is a reliable outdoor barometer that withstands harsh conditions.

For harsh environments

The Vaisala BAROCAP® Digital Barometer PTB210 is ideal for outdoor installations and harsh environments. The barometers are designed to operate in a wide temperature range, and the electronics housing provides IP65 (NEMA 4) standardized protection against sprayed water.

Features/Benefits

- 500 ... 1100 hPa or 50 ... 1100 hPa pressure ranges with serial output
- Different scalings between 500 ... 1100 hPa with analog output
- Electronics housing IP65 protected against sprayed water
- Accurate and stable measurement
- NIST traceable (certificate included)

The PTB210 barometers are ideal for use in applications such as weather stations, data buoys and ships, airports, and agrology. They are also an excellent solution for monitoring barometric pressure in industrial equipment such as laser interferometers and engine test benches.

Several pressure ranges

The PTB210 barometers are designed for various pressure ranges. They are available in two basic configurations: serial output for 500 ... 1100 hPa and 50 ... 1100 hPa and analog output with different scalings between 500 ... 1100 hPa.

Accurate and stable measurement

All the PTB210 barometers are digitally adjusted and calibrated by using electronic working standards. A higher accuracy barometer, that is fine-tuned and calibrated against a

High Precision Pressure Calibrator, is available for the 500 ... 1100 hPa pressure range.

In addition, the PTB210 integrates directly with Vaisala Static Pressure Head Series SPH10/20. This pairing offers accurate measurement in all wind conditions.

Vaisala BAROCAP® technology

The PTB210 barometers use the Vaisala BAROCAP® Sensor, a silicon capacitive absolute pressure sensor developed by Vaisala for barometric pressure applications. The Vaisala BAROCAP® Sensor provides excellent hysteresis and repeatability characteristics and outstanding temperature and long-term stability. All PTB210 barometers are delivered with a factory calibration certificate which is NIST traceable.

Technical Data

Operating range (1hPa=1mbar)

Pressure range (order specified)	
serial output	500 ... 1100 hPa 50 ... 1100 hPa
analog output	500 ... 1100 hPa 600 ... 1060 hPa 800 ... 1060 hPa 900 ... 1100 hPa
Operating temperature range	-40 ... +60 °C (-40 ... +140 °F)
Humidity range	non-condensing

Accuracy

SERIAL OUTPUT (units in hPa)			
Pressure range	500 ... 1100	50 ... 1100	
	Class A	Class B	
Non linearity*	± 0.10	± 0.15	± 0.20
Hysteresis*	± 0.05	± 0.05	± 0.10
Repeatability*	± 0.05	± 0.05	± 0.10
Calibration uncertainty**	± 0.07	± 0.15	± 0.20
Accuracy at +20 °C (+68 °F)***	± 0.15	± 0.20	± 0.35
Temperature dependence****	± 0.20	± 0.20	± 0.40
Total accuracy****	± 0.25	± 0.30	± 0.50
-40 ... +60 °C (-40 ... +140 °F)			
Long term stability (hPa/year)	± 0.10	± 0.10	± 0.20

ANALOG OUTPUT

Non linearity*	± 0.20 hPa
Hysteresis*	± 0.05 hPa
Repeatability*	± 0.05 hPa
Calibration uncertainty**	± 0.15 hPa
Accuracy at +20 °C (+68 °F)***	± 0.30 hPa
Temperature dependence****	± 0.50 hPa
Total accuracy**** -40 ... +60 °C (-40 ... +140 °F)	± 0.60 hPa
Long term stability	± 0.10 hPa/year

* Defined as the ±2 standard deviation limits of end point non-linearity, hysteresis error or repeatability error.

** Defined as ±2 standard deviation limits of inaccuracy of the working standard including traceability to NIST.

*** Defined as the root sum of the squares (RSS) of end point non-linearity, hysteresis error, repeatability error and calibration uncertainty at room temperature.

**** Defined as ±2 standard deviation limits of temperature dependence over the operating temperature range.

General

(• Factory setting)	
SERIAL OUTPUT	
Current consumption	
normal mode	< 15 mA•
power down mode	< 0.8 mA
shutdown mode	0.2 mA
Shutdown	ON/OFF
Settling time at power up	2 s
Serial I/O (factory setting•)	RS232C RS232C /TTL (optional) RS485, non isolated (optional)
parity	none, even•, odd
data bits	7•, 8
stop bits	1•, 2
Baud rate	1200, 2400, 4800, 9600•, 19200
Response time	1 s•
Resolution	0.01 hPa (1 measurement/s) 0.03 hPa (10 measurements/s)
ANALOG OUTPUT	
Outputs	0 ... 5 VDC, 0 ... 2.5 VDC (order specified)
Current consumption	
normal mode	< 8 mA
shutdown mode	0.2 mA
Shutdown	ON/OFF
Response time	500 ms
Resolution	300 µV
Measurement rate	3 measurements/s
ALL MODELS	
Supply voltage (reverse polarity protected)	
with RS232/TTL output	5 ... 28 VDC
with RS485 or analog output	8 ... 18 VDC
Max. pressure	5 000 hPa abs.
Pressure connector	M5 (10-32) internal thread
Pressure fitting	barbed fitting for 1/8" I.D. tubing
Housing	
electronics	IP65 (NEMA 4)
sensor	IP53
Housing material	PC plastic
Supply/output cable length	1, 2, 3, 5 or 10 m
Instrument	110 g
Cable	28 g/m
Electromagnetic compatibility	Complies with EMC standard EN61326-1, Generic Environment

Technical Data

Dimensions

Dimensions in mm (inches)

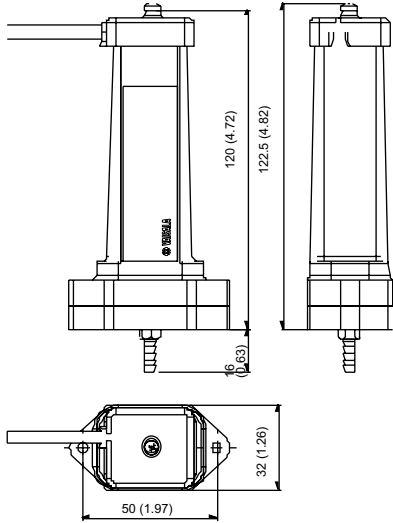

BAROCAP® is a registered trademark of Vaisala.

VAISALA

For more information, visit www.vaisala.com or contact us at sales@vaisala.com

Ref. B210942EN-A ©Vaisala 2010
This material is subject to copyright protection, with all copyrights retained by Vaisala and its individual partners. All rights reserved. Any logos and/or product names are trademarks of Vaisala or its individual partners. The reproduction, transfer, distribution or storage of information contained in this brochure in any form without the prior written consent of Vaisala is strictly prohibited. All specifications — technical included — are subject to change without notice.



Calculate and Convert.

The free web based Vaisala Humidity Calculator allows you to calculate several humidity parameters from one known humidity value. Make unit conversions on the fly, and see the effects of changing ambient conditions, like temperature and pressure. The calculator is available in several languages.

Access or download the Vaisala Humidity Calculator at www.vaisala.com/humiditycalculator

Ambient Conditions	Value	Unit Conversion
Temperature	23	°C
Pressure	1013.25	hPa
Gas type	Air	Add New
Humidity	Relative	Add New

Fill in the known parameter to calculate other values	Value	Unit Conversion
Absolute humidity (g/m ³)		g/m ³
Dewpoint		Temperature
Saturation vapor pressure (kPa)		Pressure
Absolute humidity (kg)		kg/m ³
Vapor content (g)		g/kg
Vapor content (kg)		kg/kg
Vapor pressure (kPa)		Pressure
Wet bulb		Temperature
Saturation vapor pressure (kPa)		Pressure

Available also at the Apple iTunes App Store



www.vaisala.com/humiditycalculator

VAISALA

PTB110 Barometer for Industrial Use



The Vaisala BAROCAP® Barometer PTB110 offers outstanding long-term stability.

Features/Benefits

- Vaisala BAROCAP® sensor
- Several pressure ranges
- Accuracy ± 0.3 hPa at $+20$ °C
- Long-term stability
- On/off control with external trigger
- Output voltage 0 ... 2.5 or 0 ... 5 VDC
- Current consumption less than 4 mA
- Mountable on a (35 mm wide) DIN rail
- NIST traceable (certificate included)

PTB110

The Vaisala BAROCAP® Barometer PTB110 is designed both for accurate barometric pressure measurements at a room temperature and for general environmental pressure monitoring over a wide temperature range.

Vaisala BAROCAP® Technology

The PTB110 barometer uses the Vaisala BAROCAP® Sensor, a silicon capacitive absolute pressure sensor developed by Vaisala for barometric pressure measurement applications. The sensor combines the outstanding elasticity characteristics and mechanical stability of single-crystal silicon with the proven capacitive detection principle.

Accuracy and Stability

The excellent long-term stability of the barometer minimizes or even removes the need for field adjustment in many applications.

Applications

The PTB110 is suitable for a variety of applications, such as environmental pressure monitoring, data buoys, laser interferometers, and in agriculture and hydrology.

The compact PTB110 is especially ideal for data logger applications as it has low power consumption. Also an external On/Off control is available. This is practical when the supply of electricity is limited.

Technical Data

Operating Range (1 hPa=1mbar)

Pressure ranges	500 ... 1100 hPa
	600 ... 1100 hPa
	800 ... 1100 hPa
	800 ... 1060 hPa
	600 ... 1060 hPa
Temperature range	-40 ... +60 °C (-40 ... +140 °F)
Humidity range	non-condensing

General

Supply voltage	10 ... 30 VDC
Supply voltage control	with TTL level trigger
Supply voltage sensitivity	negligible
Current consumption	less than 4 mA
in shutdown mode	less than 1 µA
Output voltage	0 ... 2.5 VDC
	0 ... 5 VDC
Output frequency	500 ... 1100 Hz
Resolution	0.1 hPa
Load resistance	minimum 10 kohm
Load capacitance	maximum 47 nF
Settling time	1 s to reach full accuracy after power-up
Response time	500 ms to reach full accuracy after a pressure step

Acceleration sensitivity	negligible
Pressure connector	M5 (10-32) internal thread
Pressure fitting	barbed fitting for 1/8"
Minimum pressure limit	0 hPa abs
Maximum pressure limit	2000 hPa abs
Electrical connector	removable connector for 5 wires (AWG 28 ... 16)
Terminals	Pin 1: external triggering
	Pin 2: signal ground
	Pin 3: supply ground
	Pin 4: supply voltage
	Pin 5: signal output

Housing material, plastic cover	ABS/PC blend
Housing classification	IP32
Metal mounting plate	Al
Weight	90 g
Electromagnetic compatibility	Complies with EMC standard EN 61326-1, Electrical equipment for measurement, control and laboratory use - EMC requirements - for use in industrial locations

Accuracy

Linearity*	±0.25 hPa
Hysteresis*	±0.03 hPa
Repeatability*	±0.03 hPa
Calibration uncertainty**	±0.15 hPa
Accuracy at +20 °C***	±0.3 hPa

* Defined as ±2 standard deviation limits of end-point non-linearity, hysteresis error or repeatability error.

** Defined as ±2 standard deviation limits of inaccuracy of the working standard including traceability to NIST.

*** Defined as the root sum of the squares (RSS) of end-point non-linearity, hysteresis error, repeatability error and calibration uncertainty at room temperature.

TOTAL ACCURACY AT

+15 ... +25 °C (+59 ... +77 °F)	±0.3 hPa
0 ... +40 °C (+32 ... +104 °F)	±0.6 hPa
-20 ... +45 °C (-4 ... +113 °F)	±1.0 hPa
-40 ... +60 °C (-40 ... +140 °F)	±1.5 hPa
Long-term stability	±0.1 hPa/year

Dimensions

Dimensions in mm (inches)

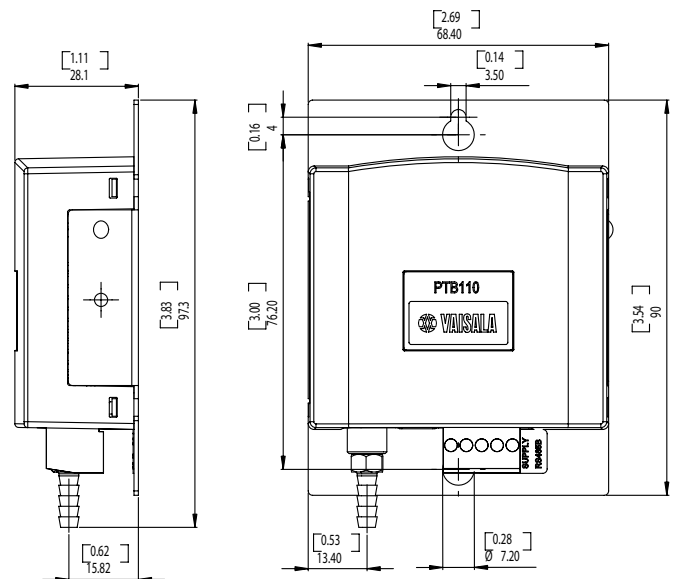

BAROCAP® is a registered trademark of Vaisala.

VAISALA

For more information, visit www.vaisala.com or contact us at sales@vaisala.com

Ref. B210681EN-B ©Vaisala 2009
This material is subject to copyright protection, with all copyrights retained by Vaisala and its individual partners. All rights reserved. Any logos and/or product names are trademarks of Vaisala or its individual partners. The reproduction, transfer, distribution or storage of information contained in this brochure in any form without the prior written consent of Vaisala is strictly prohibited. All specifications — technical included — are subject to change without notice.



SPH10/20 Static Pressure Heads for Minimizing Wind Induced Error

Wind induced effects are one of the main sources of error when measuring barometric pressure. Variations due to strong and gusty wind can be overcome by using a static pressure head to 'filter out' the effect of dynamic pressure.

The Vaisala Static Pressure Head Series SPH10/20 are designed to minimize the errors caused by wind. The wind tunnel tested structure is both horizontally and vertically symmetrical. This design ensures reliable barometric pressure measurements in all weather.

Ideal for outdoor installations

Vaisala's static pressure heads are available in two models: the Vaisala Static Pressure Head SPH10 is a basic version, and the Vaisala Static Pressure Head SPH20 is a heated version for reliable operation in snowy and icy conditions. The warmed SPH20 contains a thermostat that switches on the warming power at temperatures, where the risk of icing may occur.

Composed of ultraviolet stabilized PC plastics and offshore aluminium, the

SPH10/20 static pressure heads are durable and weather resistant.

The SPH10/20 protects against rain and condensed water, thus preventing capillary condensation of a water column in the pressure channel which results in pressure error. The drain holes in the lower plate allow rain and water to flow out. The static pressure heads have internal netting which prevents insects and debris from blocking the pressure channel.

Carefree maintenance

The SPH10/20 static pressure heads are easy to install and disassemble, service and clean – even at the installation site. Vaisala BAROCAP® Digital Barometer PTB210 can be installed directly on top of the SPH10/20 static pressure heads. Other barometers can be connected to the heads with pressure tubing. SPH10 and SPH20 are a perfect pair for all Vaisala barometers. They ensure an accurate and reliable measurement in all weather conditions.



The SPH10/20 is easy to install and connect. In the picture, a SPH10 is connected to a PTB210 barometer.

Features/Benefits

- Minimizes wind induced error
- Reliable barometric pressure measurement in all weather
- Wind tunnel tested structure
- Easy-to-clean
- Easy-to-install

Technical Data

General

Operating temperature	-60 ... +80 °C (-76 ... +176 °F)
Weight	
SPH10	800 g
SPH20	1360 g
Material	PC plastic, offshore aluminium
Mounting	with 2 bolts (M6 X 20 mm min)
Hose connection	barbed fitting for 4 mm I.D. hose or Rp1/4 thread (parallel)

SPH20

Electrical connections	M12 connector
Power supply	factory setting 12 V changed connection 24 V
Thermostat switching temperature	
On	+4 °C (±3 °C) +39.2 °F (±4.4 °F)
Off	+13 °C (±3 °C) +55.4 °F (±4.4 °F)
Power consumption during heating	70 W

Dimensions

Dimensions in mm

SPH10

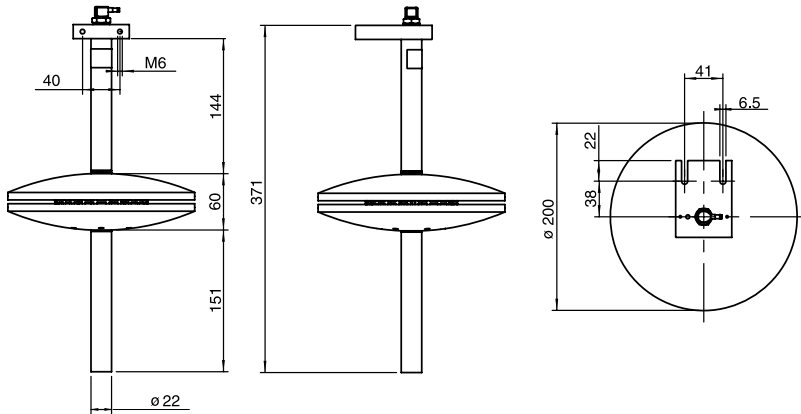

SPH20

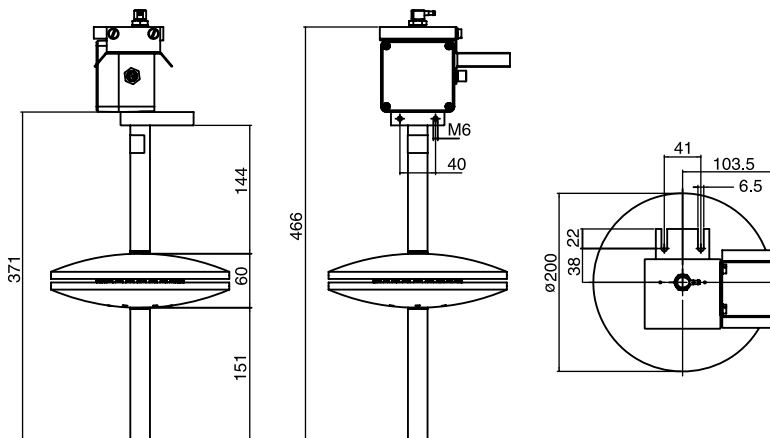

VAISALA

For more information, visit
www.vaisala.com or contact
 us at sales@vaisala.com

Ref. B210907EN-A ©Vaisala 2009
 This material is subject to copyright protection, with all
 copyrights retained by Vaisala and its individual partners. All
 rights reserved. Any logos and/or product names are trademarks
 of Vaisala or its individual partners. The reproduction, transfer,
 distribution or storage of information contained in this brochure
 in any form without the prior written consent of Vaisala is strictly
 prohibited. All specifications — technical included — are subject
 to change without notice.



Vaisala Differential Pressure Transmitter PDT102



Vaisala Differential Pressure Transmitter PDT102 with process valve actuator and test jacks.

Features

- In-place system calibration and on-line monitoring without disturbing process tubes with optional process valve actuator and test jacks
- Ultrathin profile ideally suited for DIN rail mount reduces installation and calibration costs
- High accuracy, two options; 0.25% or 0.50% of span designed for use in critical monitoring of cleanrooms for pharmaceutical, biotechnology, medical device and semiconductor controlled manufacturing environments
- Extremely robust MEMS silicon sensor technology provides very high accuracy, sensitivity, stability and durability
- NIST traceable 9 point calibration with certificate
- Front side accessible zero and span adjustment potentiometers

Operating Environment

Vaisala Differential Pressure Transmitter PDT102 is a high performance instrument designed primarily for life science and high technology cleanroom applications. The front panel includes zero and span adjustment potentiometers for convenient adjustment. The PDT102 transmitter is ideal for incorporating into the Vaisala Veriteq Continuous Monitoring System to measure and monitor the critical environmental parameters as required in regulated environments.

Performance

The PDT102 offers very high accuracy, sensitivity and stability with two options for accuracy, 0.25% or 0.50% of span providing a highly

reliable and repeatable measurement. The sensor uses a micro-machined, ultra-thin silicon diaphragm which provides inherent sensor repeatability and stability. The sensor enables precise measurement and control in high performance cleanrooms. The PDT102 transmitter is available with voltage output (3-wire) or current output (2-wire).

Available Options

Online monitoring of the PDT102 is simple using the optional process valve actuator and the front access test jacks. The front access test jacks provide online process reference signal or calibration signal without disconnecting power supply wiring. Measurements can be made using a standard multimeter.

Technical Data

Performance

Measurement ranges (bidirectional)	±50 Pa ±0.25 in H ₂ O
Overpressure	
proof pressure	0.7 bar
burst pressure	1.7 bar
static pressure	1.7 bar
Pressure type	differential, gauge, vacuum and compound
Accuracy	0.25 % span or 0.5 % span, depending on choice
Repeatability	
for 0.25 % span accuracy	0.03 %
for 0.5 % span accuracy	0.05 %
Electrical resolution	1 x 10 ⁻⁴ span
Long-term stability	≤0.5 % span/year
Response time (10 ... 90 %)	250 ms
Warm-up time	15 s
Compensated temperature range	+2 ... +57 °C (+35.6 ... +134.6 °F)
Temperature dependence	±0.36 % / 10 K (reference 20 °C (68 °F))
Mounting position	
error (zero adjustable)	≤0.25 %
Adjustments (front accessible)	
zero	±5 % span
span	±3 % span

Operating Environment

Operating temperature	-29 ... +70 °C (-20.2 ... +158 °F)
Storage temperature	-40 ... +82 °C (-40 ... +179.6 °F)
Electromagnetic compatibility (EN 61326-1), basic immunity test requirements	

Note: If used in an electromagnetic field of 3 V/m, with narrow frequency area of 80 - 120 Mhz, it is possible that the current output of PDT102 can deviate max. 0.3% (with accuracy specified 0.25%).

Inputs and Outputs

Process connection	1/8 NPT female according to ANSI/ASME B1.20.1
Output signal	
2-wire	4 ... 20 mA
3-wire	0 ... 5 V
Operating voltage	12 ... 36 VDC
Max. loop resistance for 4 ... 20 mA	≤ (Supply voltage - 12V)/0.022 A
Supply current	
for 0 ... 5 V output	max. 10 mA
for 4 ... 20 mA output	max. 20 mA
Electrical connection	Screw terminals, 12 ... 22 AWG (0.33 up to 3.31 mm ²)

Mechanics

Medium (measured gas)	clean and dry air, non-conducting and non-corrosive gases
Material	
process connection	brass
sensor element	silicon, aluminium, glass
case	Polycarbonate, glass filled (UL94-V-1)
Mounting	DIN rail types EN 50022, EN 50035 and EN 50045
Housing classification	IP30
Weight	0.16 kg

Dimensions

Dimensions in mm

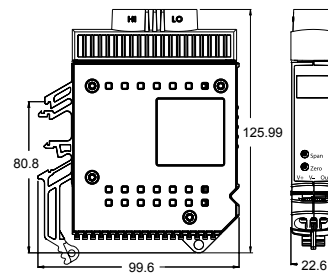

Figure 1

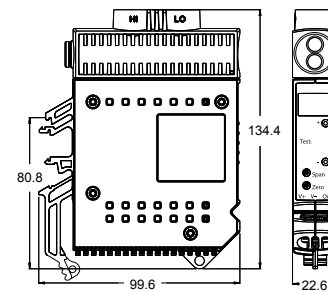

Figure 2 with Process Valve Actuator and Test Jacks

Order Information for PDT102

PDT102 - XXXT

Measurement range:	
P (+/-50 Pa) or W (+/-0.25 in H ₂ O)	↑
Accuracy: 2 (0.25 % span) or 5 (0.5 % span)	↑
Output: C (current) or V (voltage)	↑
Option: (blank) or T	↑

VAISALA

For more information, visit
www.vaisala.com or contact
us at sales@vaisala.com

Ref. B211083EN-B ©Vaisala 2011
This material is subject to copyright protection, with all
copyrights retained by Vaisala and its individual partners. All
rights reserved. Any logos and/or product names are trademarks
of Vaisala or its individual partners. The reproduction, transfer,
distribution or storage of information contained in this brochure
in any form without the prior written consent of Vaisala is strictly
prohibited. All specifications — technical included — are subject
to change without notice.



Vaisala Differential Pressure Transmitter PDT101



Vaisala Differential Pressure Transmitter PDT101 with current output (black) and voltage output (green).

Features

- Easy mounting on wall, DIN rail or panel
- 2 pressure ranges (Pa and in H₂O)
- Accessible zero and span adjustment potentiometers
- 1/4" brass tubing connections
- LED status indicator
- Specially designed for critical and regulated environments
- Euro style detachable connector
- NIST traceable (certificate included)

Operating Environment

Vaisala Differential Pressure Transmitter PDT101 is designed especially for demanding life science and high technology cleanroom applications. The PDT101 transmitter is ideal for incorporating into the Vaisala Veriteq Continuous Monitoring System to measure and monitor the critical environmental parameters as required in regulated environments.

Performance

The PDT101 offers high accuracy, sensitivity and stability with accuracy 0.40% of span providing a highly reliable and repeatable measurement. The sensor uses a micro-machined, ultra-thin silicon diaphragm which provides inherent sensor repeatability and stability. The sensor enables precise measurement and control in high performance

cleanrooms. The PDT101 transmitter is available with voltage output (3-wire) or current output (2-wire).

Zero and span adjustment screws are available on every PDT101 model. Both adjustments are accessible from the front of the unit.

Applications

The PDT101 is suitable for high performance cleanroom environments in the life science, semiconductor and electronics industries. As part of a continuous monitoring system, it is highly suitable for regulated environments where continuous, documented and redundant data is a requirement to meet FDA regulations. The compact design is well suited for mounting in a cleanroom or in the adjacent corridor with LED indicator lights for quick and easy power status spotcheck.

Technical Data

Performance

Measurement ranges (bidirectional)	±60 Pa ±0.25 in H ₂ O
Overpressure	
proof pressure	1.0 bar
burst pressure	1.7 bar
static pressure	1.7 bar
Pressure type	differential, gauge, vacuum and compound
Accuracy (terminal point, incl. effect of linearity, hysteresis and repeatability)	0.4 % span
Long-term stability	≤0.5 % span/year
Response time (10 ... 90 %)	250 ms
Warm-up time	15 s
Compensated temperature range	+2 ... +54 °C (+35.6 ... +129.2 °F)
Temperature dependence	±0.54 % / 10 K (reference 20 °C (68 °F))
Mounting position	
error (zero adjustable)	≤1 %/g (calibration in vertical position is standard)
Adjustments (front accessible)	
zero	±5 % span
span	±3 % span

Operating Environment

Operating temperature	-18 ... +70 °C (-0.4 ... +158 °F)
Storage temperature	-40 ... +82 °C (-40 ... +179.6 °F)
Electromagnetic compatibility (EN 61326-1), basic immunity test requirements	
Note: If used in an electromagnetic field of 3 V/m, with narrow frequency area of 80 - 120 Mhz, it is possible that the current output of PDT101 can deviate max. 0.8% (with accuracy specified 0.4%).	

Inputs and Outputs

Process connection	1/4" barbed fittings
Output signal	
2-wire	4 ... 20 mA
3-wire	0 ... 5 VDC (user selectable 0 ... 10 VDC)
Operating voltage	
2-wire output 4 ... 20 mA	12 ... 36 VDC
3-wire output 0 ... 5 VDC	11.5 ... 36 VDC
3-wire output 0 ... 10 VDC	14 ... 36 VDC or 24 VAC
Max. loop resistance	
for 4 ... 20 mA	≤ (Supply voltage - 12V)/0.022 A
Supply current	max. 20 mA for 4 ... 20 mA output signal
Optical process diagnostics	LED visual indicator
Electrical connection	Euro style pluggable terminal block accepts 12...26 AWG wire (0.13 up to 3.31 mm ²)

Mechanics

Medium (measured gas)	clean and dry air, non-conducting and non-corrosive gases
Material	
process connection	brass
sensor element	silicon, aluminium, glass
case	NEMA type 1 fire-retardant ABS 1 (meets UL94-5VA)
Mounting	threaded fastener for wall mounting or DIN rail type EN50022
Housing classification	IP40
Weight	0.07 kg

Dimensions

Dimensions in mm

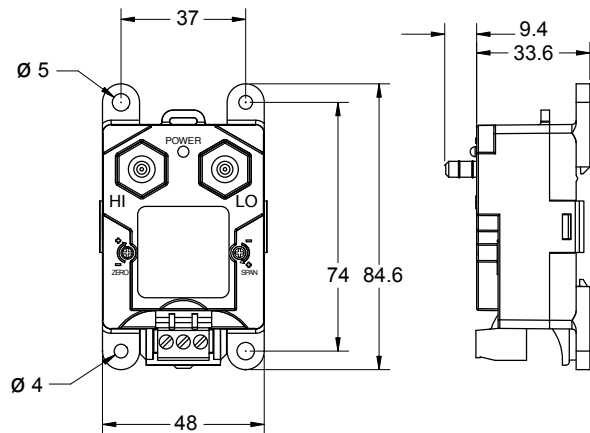

Order Information for PDT101

PDT101 - XXX

Measurement range: P (+/-60 Pa) or W (+/-0.25 in H ₂ O)	↑
Accuracy: 4 (0.4 % span)	↑
Output: C (current) or V (voltage)	↑

VAISALA

For more information, visit
www.vaisala.com or contact
us at sales@vaisala.com

Ref. B211082EN-B ©Vaisala 2011
This material is subject to copyright protection, with all copyrights retained by Vaisala and its individual partners. All rights reserved. Any logos and/or product names are trademarks of Vaisala or its individual partners. The reproduction, transfer, distribution or storage of information contained in this brochure in any form without the prior written consent of Vaisala is strictly prohibited. All specifications — technical included — are subject to change without notice.



Vaisala Weather Transmitter WXT520 Access to Real Time Weather Data



The WXT520 has an automatic control circuit that switches the heating on at low temperatures.

Features/Benefits

- Measures 6 most essential weather parameters
- Accurate and stable
- Low power consumption – works also with solar panels
- Compact, light-weight
- Easy to install with one-bolt mounting method
- No moving parts
- Heating available
- Vaisala Configuration Tool for pc
- USB connection
- IP66 housing with mounting kit
- Applications: weather stations, dense networks, harbors, marinas

WXT520

The Vaisala Weather Transmitter WXT520 measures barometric pressure, humidity, precipitation, temperature, and wind speed and direction.

To measure wind speed and direction, the WXT520 has the Vaisala WINDCAP® Sensor that uses ultrasound to determine horizontal wind speed and direction. The array of three equally spaced transducers on a horizontal plane is a Vaisala specific design. Barometric pressure, temperature, and humidity measurements are combined in the PTU module using capacitive measurement for each parameter. It is easy to change the module without any contact with the sensors.

The WXT520 is immune to flooding clogging, wetting, and evaporation losses in the rain measurement.

Measuring Acoustic Precipitation

The WXT520 precipitation measurement is based on the unique Vaisala RAINCAP® Sensor, which detects the impact of individual rain drops. The signals exerting from the impacts are proportional to the volume of the drops. Hence, the signal from each drop can be converted directly to the accumulated rainfall.

The WXT520 measures accumulated rainfall, rain intensity and duration of the rain — all in real time.

The Vaisala RAINCAP® Sensor is the only maintenance-free precipitation sensor on the market.

Technical Data

Wind

SPEED	
range	0 ... 60 m/s
response time	250 ms
accuracy	
0 ... 35 m/s	± 0.3 m/s or $\pm 3\%$, whichever is greater
35 m/s ... 60 m/s	$\pm 5\%$
output resolutions and units	0.1 m/s, 0.1 km/h, 0.1 mph, 0.1 knots
DIRECTION	
azimuth	0 ... 360°
response time	250 ms
accuracy	$\pm 3^\circ$
output resolution and unit	1°

Liquid Precipitation

RAINFALL	
	cumulative accumulation after the latest automatic or manual reset
output resolutions and units	0.01 mm, 0.001 inches
accuracy	5%*
RAINFALL DURATION	
	counting each ten-second increment whenever water droplet is detected
output resolution and unit	10 s
RAIN INTENSITY	
	one-minute running average in ten-second steps
range	0 ... 200 mm/h (broader range with reduced accuracy)
output resolutions and units	0.1 mm/h, 0.01 inches/h
HAIL	
	cumulative amount of hits against the collecting surface
output resolutions and units	0.1 hits/cm ² , 0.01 hits/in ² , 1 hits
HAIL DURATION	
	counting each ten-second increment whenever hailstone is detected
output resolution and unit	10 s
HAIL INTENSITY	
	one-minute running average in ten-second steps
output resolutions and units	0.1 hits/cm ² h, 1 hits/in ² h, 1 hits/h

* Due to the nature of the phenomenon, deviations caused by spatial variations may exist in precipitation readings, especially in a short time scale. The accuracy specification does not include possible wind induced errors.

Air Temperature

Range	-52 ... +60 °C (-60 ... +140 °F)
Accuracy for sensor at +20 °C	± 0.3 °C (± 0.5 °F)
Accuracy over temperature range (see graph below)	

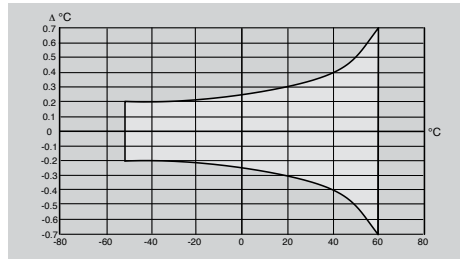

Output resolutions and units	0.1 °C, 0.1 °F
------------------------------	----------------

Barometric Pressure

Range	600 ... 1100 hPa
Accuracy	± 0.5 hPa at 0 ... +30 °C (+32 ... +86 °F) ± 1 hPa at -52 ... +60 °C (-60 ... +140 °F)
Output resolutions and units	0.1 hPa, 10 Pa, 0.0001 bar, 0.1 mmHg, 0.01 inHg

Relative Humidity

Range	0 ... 100 %RH
Accuracy	± 3 %RH within 0 ... 90 %RH ± 5 %RH within 90 ... 100 %RH
Output resolution and unit	0.1 %RH

General

Operating temperature	-52 ... +60 °C (-60 ... +140 °F)
Storage temperature	-60 ... +70 °C (-76 ... +158 °F)
Operating voltage	5 ... 32 VDC
Typical power consumption	3 mA at 12 VDC (with defaults)
Heating voltage	5 ... 32 VDC / 5 ... 30 VAC _{RMS}
Serial data interface	SDI-12, RS-232, RS-485, RS-422, USB connection,
Weight	650 g (1.43 lb)
Housing	IP65
Housing with mounting kit	IP66

Electromagnetic Compatibility

Complies with EMC standard EN61326-1; Industrial	
Environment IEC standards	IEC 60945/61000-4-2 ... 61000-4-6

VAISALA

For more information, visit www.vaisala.com or contact us at sales@vaisala.com

Ref. B210417EN-H ©Vaisala 2011
This material is subject to copyright protection, with all copyrights retained by Vaisala and its individual partners. All rights reserved. Any logos and/or product names are trademarks of Vaisala or its individual partners. The reproduction, transfer, distribution or storage of information contained in this brochure in any form without the prior written consent of Vaisala is strictly prohibited. All specifications — technical included — are subject to change without notice.



WMT52 Ultrasonic Wind Sensor for Accurate and Stable Measurement



The Vaisala WINDCAP® Ultrasonic Wind Sensor WMT52 - stable and inexpensive wind measurement for demanding applications.

Features/Benefits

- Measures horizontal wind speed and wind direction
- Triangular design ensures excellent data availability
- No moving parts
- Maintenance-free
- Optional heating available
- Compact, durable and robust
- Low power consumption
- IP66 housing with mounting kit
- Applications: marine, wind energy, environmental monitoring

Proven Vaisala Performance

The Vaisala WINDCAP® Ultrasonic Wind Sensor WMT52 incorporates decades of Vaisala experience in wind measurement using ultrasound to determine horizontal wind speed and direction.

With no moving parts, the WMT52 has high sensitivity as the measurement time constant and starting threshold are virtually zero. This makes it superior to the conventional mechanical wind sensors.

The WMT52 is designed to operate without periodic field calibration and maintenance.

Applications

The WMT52 is ideal for use in marine applications as the housing with the mounting kit is water resistant. The WMT52 is also suitable for wind energy and environmental monitoring, for example, for measuring the distribution of air pollution and road tunnel ventilation.

Easy to Install

The WMT52 is delivered fully assembled and configured from the factory. With the Vaisala Configuration Software Tool you can change the settings, such as averaging times, output mode, update intervals, measured variables and message contents.

The WMT52 can be mounted either on top of a pole mast or on a cross arm.

When using the optional mounting kit, the north alignment needs to be performed only once.

Heating

The optional heating available in the WMT52 assists measurements in the freezing weather conditions and during snowfall.

As the heating circuit is independent of the operational power, separate supplies can be used. Heating is switched on automatically at low temperatures, well before the freezing point.

Low power consumption

The WMT52 has very low power consumption; during the idle mode the device typically consumes about 2 ... 3 mW.

Technical Data

Wind

WIND SPEED	
Range	0 ... 60 m/s
Response time	250 ms
Available variables	average, maximum, and minimum
Accuracy	
0 ... 35 m/s	±0.3 m/s or ±3 % whichever is greater
35 m/s ... 60 m/s	±5 %
Output resolution	0.1 m/s (km/h, mph, knots)
WIND DIRECTION	
Azimuth	0 ... 360°
Response time	250 ms
Available variables	average, maximum, and minimum
Accuracy	±3°
Output resolution	1°
MEASUREMENT FRAME	
Averaging time	1 ... 3600 s (=60 min), at one second steps on the basis of samples taken at 4 Hz rate (configurable)
Update interval	1 ... 3600 s (=60 min), at one-second steps

General

Self-diagnostics	separate supervision message, unit/status fields to validate measurement quality
Start-up	automatic, <10 s from power on to the first valid output
Serial data interface	SDI-12, RS-232, RS-485, RS-422, USB connection
Communication protocols	SDI-12 v1.3, ASCII automatic & polled, NMEA 0183 v. 3.0 with query option
Baud rate	1200 ... 115 200
Operating temperature	-52 ... +60 °C (-60 ... +140 °F)
Storage temperature	-60 ... +70 °C (-76 ... +158 °F)
Dimensions	
height	139 mm (5.7")
diameter	114 mm (4.49")
weight	510 g (1.12 lb)
Housing	IP65
Housing with mounting kit	IP66
Vibration	IEC 60945 paragraph 8

Power Supply

Operating voltage	5 ... 32 VDC
Power consumption on average	
minimum	0.1 mA at 12 VDC
maximum	14 mA at 5 VDC
typical	3 mA at 12 VDC (default measuring intervals)
Heating voltage	5 ... 32 VDC / 5 ... 30 VAC _{RMS}

Accessories

Mounting kit	212792
Bird spike kit	212793
Surge protector for sensor	WSP150

Electromagnetic Compatibility

Complies with EMC standard: EN61326-1, Industrial Environment	
IEC standards	IEC 60945/61000-4-2 ... 61000-4-6

Dimensions

Dimensions in mm (inches)

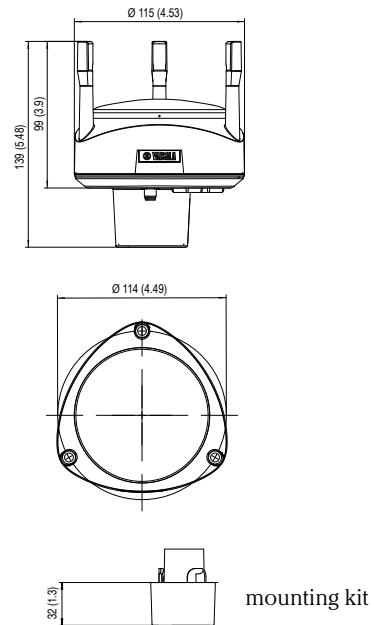

WINDCAP® is a registered trademark of Vaisala.

VAISALA

For more information, visit www.vaisala.com or contact us at sales@vaisala.com

Ref. B210553EN-D ©Vaisala 2010
This material is subject to copyright protection, with all copyrights retained by Vaisala and its individual partners. All rights reserved. Any logos and/or product names are trademarks of Vaisala or its individual partners. The reproduction, transfer, distribution or storage of information contained in this brochure in any form without the prior written consent of Vaisala is strictly prohibited. All specifications — technical included — are subject to change without notice.



WA15 Wind Set for High Performance Wind Measurement



The WA15 is based on accurate sensors installed on a large crossarm. It is designed for demanding wind measurement applications.

With a proven track record of successful installations, the Vaisala Wind Set WA15 has earned its reputation as the industry standard in the wind sensor market.

The WA15 consists of a Vaisala Anemometer WAA151, a Vaisala Wind Vane WAV151, an optional crossarm, a power supply and cabling.

Anemometer with Excellent Linearity

The WAA151 is a fast response, low-threshold anemometer. Three lightweight, conical cups mounted on the cup wheel, provide excellent linearity over the entire operating range, up to 75 m/s.

A wind-rotated chopper disc attached to the shaft of the cup wheel cuts an infrared light beam 14 times

Features/Benefits

- High-performance wind measurement set
- Long and successful track record in meteorological applications
- Accurate wind speed and direction measurement
- Low measurement starting threshold
- Conical anemometer cups provide excellent linearity
- Heated shaft prevents bearings from freezing

per revolution. This generates a pulse output from the phototransistor.

The output pulse rate is directly proportional to wind speed (e.g. 246 Hz = 24.6 m/s). However, for the highest accuracy, the characteristic transfer function should be used to compensate for starting inertia. (See technical data.)

Sensitive Wind Vane

The WAV151 is a counter-balanced, low-threshold, optoelectronic wind vane. Infrared LEDs and phototransistors are mounted on six orbits on each side of a 6-bit GRAY-coded disc. Turned by the vane, the disc creates changes in the code received by the phototransistors. The output code resolution is $\pm 2.8^\circ$.

Heated Bearings Withstand Cold Weather

Heating elements in the shaft tunnels of both the anemometer and vane keep the bearings above freezing in cold climates.

Complete Package Available

The anemometer and vane are designed to be mounted on Vaisala crossarms.

The WHP151 power supply provides the operating and heating power needed for the WA15. The power supply, as well as the signal and power cables are available as options.

Technical Data

Vaisala Wind Set WA15

Options and Accessories

Crossarm and termination box	WAC151
16-lead signal cable	ZZ45048
6-lead power cable	ZZ45049
Crossarm and analog transmitter	WAT12
6-lead cable for signal and power	ZZ45049
Crossarm and serial RS485 transmitter	WAC155
Serial RS485 transmitter card	WAC155CB
Power supply	WHP151
Set of bearings and gasket	16644WA
Cup assembly	7150WA
Tail assembly	6389WA

Technical Data

Vaisala Anemometer WAA151

Wind Speed

Measurement range	0.4 ... 75 m/s
Starting threshold	< 0.5 m/s *
Distance constant	2.0 m
Characteristic transfer function	$U = 0.328 + 0.101 \times R$ (where U = wind speed [m/s], R = output pulse rate [Hz])
Accuracy (within range 0.4 ... 60 m/s)	
with characteristic transfer function	± 0.17 m/s **
with transfer function $U = 0.1 \times R$	± 0.5 m/s***

General

Operating power supply	$U_{in} = 9.5 \dots 15.5$ VDC, 20 mA typical
Heating power supply	AC or DC 20 V, 500 mA nominal
Output	0 ... 750 Hz square wave
Transducer output level	
with $I_{out} < +5$ mA	high state $> U_{in} - 1.5$ V
with $I_{out} > -5$ mA	low state < 2.0 V
Settling time after power turn-on	< 30 μ s
Plug 6-PIN	MIL-C-26482 type
Cabling	6-wire cable through crossarm
Recommended connector at cable end	SOURIAU MS3116F10-6P
Operating temperature with heating	$-50 \dots +55$ °C ($-58 \dots +131$ °F)
Storage temperature	$-60 \dots +70$ °C ($-76 \dots +158$ °F)
Material	
housing	AlMgSi, grey anodized
cups	PA, reinforced with carbon fibre
Dimensions	240 (h) \times 90 (\varnothing) mm
Swept radius of cup wheel	91 mm
Weight	570 g

Test Compliance

Wind tunnel tests	ASTM standard method D5096-90
Exploratory vibration test	MIL-STD-167-1
Humidity test	MIL-STD-810E, Method 507.3
Salt fog test	MIL-STD-810E, Method 509.3

Complies with EMC standard EN61326-1:1997 + Am1:1998 + Am2:2001; Generic Environment

- * Measured with cup wheel in position least favoured by flow direction. Optimum position gives approx. 0.35 m/s threshold.
- ** Standard Deviation
- *** Typical error vs. speed with the "simple transfer function" used.

RANGE (m/s)	0-3	3-10	10-17	17-24	24-31	31-37	37-44	44-51	51-58	58-65
ERROR (m/s)	-0.4	-0.3	-0.2	-0.1	0.0	+0.1	+0.2	+0.3	+0.4	+0.5

Vaisala Wind Vane WAV151

Wind Direction

Measurement range at wind speed 0.4 ... 75 m/s	0 ... 360°
Starting threshold	< 0.4 m/s
Resolution	± 2.8 °
Damping ratio	0.19
Overshoot ratio	0.55
Delay distance	0.4 m
Accuracy	better than ± 3 °

General

Operating power supply	$U_{in} = 9.5 \dots 15.5$ VDC, 20 mA typical
Heating power supply	AC or DC 20 V, 500 mA nominal
Output code	6-bit parallel GRAY
Output levels	
With $I_{out} < +5$ mA	high state $> U_{in} - 1.5$ V
With $I_{out} > -5$ mA	low state < 1.5 V
Settling time after power turn-on	< 100 μ s
Plug 10-PIN	MIL-C-26482 type
Cabling	10-wire cable through crossarm
Recommended connector at cable end	SOURIAU MS3116F12-10P
Operating temperature with heating	$-50 \dots +55$ °C ($-58 \dots +131$ °F)
Storage temperature	$-60 \dots +70$ °C ($-76 \dots +158$ °F)
Material	
housing	AlMgSi, grey anodized
wave	Alsi 12 anodized
Dimensions	300 (h) \times 90 (\varnothing) mm
Swept radius of vane	172 mm
Weight	660 g

Test Compliance

Wind tunnel tests	ASTM standard method D5366-93 (for starting threshold, distance constant, transfer function)
Exploratory vibration test	MIL-STD-167-1
Humidity test	MIL-STD-810E, Method 507.3
Salt fog test	MIL-STD-810E, Method 509.3

Complies with EMC standard EN61326-1:1997 + Am1:1998; Am2:2001; Generic Environment

VAISALA

For more information, visit www.vaisala.com or contact us at sales@vaisala.com

Ref. B210382EN-B ©Vaisala 2009
This material is subject to copyright protection, with all copyrights retained by Vaisala and its individual partners. All rights reserved. Any logos and/or product names are trademarks of Vaisala or its individual partners. The reproduction, transfer, distribution or storage of information contained in this brochure in any form without the prior written consent of Vaisala is strictly prohibited. All specifications — technical included — are subject to change without notice.



Vaisala Service Offering

High precision instruments need to be calibrated on a regular basis to ensure continued optimal performance. Vaisala offers a standard (service center) calibration for almost all of its equipment. The measurement points are defined and the calibrations are sold as products with a fixed price. These calibrations are traceable and ISO 9001 compliant (ANSI-Z540-1-1994 in our US Service Center).

For most Vaisala instruments, the calibration service includes a calibration certificate with the 'before' and 'after' adjustment data.

Accredited ISO/IEC 17025 and ISO 10012 compliant calibrations are available for many Vaisala products as well.

Vaisala Service Centers are accredited and their working procedures are approved by third party organizations. This is confirmed by the name and logo of the local accrediting body appearing on the report documentation. The documentation includes uncertainty calculations. Accredited calibrations are recommended especially when formal third party recognition for calibration is required. This recognition is for example required for instruments used as reference

standards, or to meet various demands from different authorities.

All accredited calibrations comply with ISO 17025 and are traceable to international standards.

When shipping your instrument to Vaisala for calibration or when a repair is required, Vaisala HelpDesk is the first point of contact. An RMA number (Return Material Authorization) is provided and used to track all material returned by the customer.

Lifetime Accuracy with Vaisala Service Agreement

Regular maintenance is a key factor in ensuring measurement accuracy.

A Vaisala Service Agreement is a convenient way to gain access to professional support over the life cycle of your instruments. Agreements can be customized to support highest uptime and accuracy of your instruments.

A Vaisala Service Agreement is designed to fulfill customer needs – we will proceed step by step to find out the most suitable solution for your application. Let us do the job and you can concentrate on the results!

Add Benefits with Options

The Vaisala Service Agreements are available with multiple optional services. You can select the options based on your needs.

- **SCHEDULED PART DELIVERY:** With this option Vaisala will keep an exchange unit (or units) in stock which will be shipped to you before the recommended calibration or maintenance time.
- **PRIORITY TECHNICAL SUPPORT:** Priority technical support increases uptime of your operations. Our response time to your technical inquiries can be agreed according to your need.
- **EXTENDED WARRANTY:** Secure your investment against accidental breakdowns for years to come – let Vaisala carry the risk of unpredictable repairs. You get all the benefits of Vaisala's standard warranty conditions, but for much longer.
- **REPAIR AND CALIBRATION:** Vaisala Returns On the Web (ROW) is a system for easy shipping of Vaisala instruments for calibration or repair. The system processes your service order step-by-step and produces all required shipping documents and instructions needed.

Calibration is Our Core Operation

Standard (Service Center) Calibrations				
Service Center	European Service Center	China Service Center	Asian Service Center	North American Service Center
Location	Helsinki, Finland	Beijing, China	Tokyo, Japan	Boston, MA, USA
Humidity	√	√	√	√
Temperature	√	√	√	√
Dew Point Temperature	√	√	√	√
Barometric Pressure	√		√	√

Table 1. Standard (service center) calibration is available globally in all Vaisala Service Centers.

Traceability of Measurement Parameters				
	ISO9001 compliant		ISO17025 compliant	
	Standard Calibration	Traceability	Accredited Calibration	Traceability
Relative Humidity	Yes	NIST	Yes	JCSS/NIST, Salt Solutions
Temperature	Yes	NIST	Yes	NIST
Dew Point Temperature	Yes	NIST, JCSS	Yes	JCSS
Barometric Pressure	Yes	NIST	Yes	NIST
Carbon Dioxide	Yes	NIST, NMI	Not available	-

Table 2. Traceability of different measurement parameters.



Accredited Body			
Service Center	European Service Center	Asian Service Center	North American Service Center
Location, Laboratory, Code	Helsinki, Finland, K008	Tokyo, Japan, 0123	Boston, MA, USA, 112765
			
Accredited Parameters			
Relative Humidity	√	√	√
Temperature	√		√
Dew Point Temperature		√	√
Barometric Pressure	√		

Table 3. Accredited parameters in Vaisala Service Centers.

Vaisala Filters

Group A: 12 mm Diameter, Standard Length, Female Threads



0195

0195
Brass, sintered filter, 133 microns, \varnothing 12.0 mm
Group: A



10159HM

10159HM
Membrane filter, 0.2 microns, \varnothing 12.0 mm
Group: A



6221

6221
Plastic grid, 2 mm protection, \varnothing 12.0 mm
Group: A



230727SP

230727SP
Membrane filter, 0.2 microns, \varnothing 12.0 mm
Group A

Group B: 12 mm Diameter, Long Length, Female Threads (Could be used in place of "A" type filters)



DRW010276SP

DRW010276SP
PPS plastic grid filter, 6.5 mm, \varnothing 12 mm
Group: B



HM47280SP

HM47280SP
Stainless steel sintered filter, 38 μ m, \varnothing 12mm
Group: B



DRW010281SP

DRW010281SP
PPS plastic grid with stainless steel net,
15 μ m, \varnothing 12 mm
Group: B



HM47453SP

HM47453SP
Stainless steel filter guard for vacuum,
3.15 mm, \varnothing 12 mm
Group: B



DRW212987SP

DRW212987SP
Sintered filter, 40 μ m, \varnothing 12 mm
Group: B



219452SP

219452SP
Sintered PTFE filter, \varnothing 12 mm
Group: B

Vaisala Filters continued

Group C: 12 mm Diameter, Male Threads



17039HM
Membrane filter 0.2 μm , \varnothing 12 mm
Group: C

17039HM



DRW010522
Plastic Grid, 2 mm, \varnothing 12 mm
Group: C

DRW010522



HMM46670SP
Sintered stainless steel filter, 38 μm ,
 \varnothing 12.0 mm
Group: C

HMM46670SP



DRW010525
Membrane filter, 0.2 μm , \varnothing 12 mm
Group: C

DRW010525

Group D: 13.5 mm Diameter, Male Threads



16452SP
Sintered filter, stainless steel, 37
microns, \varnothing 13.5 mm
Group: D

16452SP



17230HMSP
PTFE membrane, 3.5 μm , \varnothing 13.5 mm.
Group: D

17230HMSP



16562SP
PPS Grid, 2 mm, \varnothing 13.5 mm
Group: D

16562SP



HM46999SP
Sintered stainless steel filter, 2mm, \varnothing 13.5
Group: D

HM46999SP



16720HMSP
PPS Grid and stainless steel net, 14 μm ,
 \varnothing 13.5 mm
Group: D

16720HMSP

Vaisala Filters continued

Group E: 18.5 mm Diameter, Female Threads



6597

6597
Plastic grid, 2.5 mm, \varnothing 18.5 mm
Group: E



2787HM

2787HM
Membrane filter, 0.2 microns, \varnothing 18.5 mm
Group: E



HM46717

HM46717
Plastic grid, 2.5 mm, \varnothing 18.5 mm
Group: E



16126HM

16126HM
Metallized membrane filter, 0.5 μ m, \varnothing 18.5 mm
Group: E

Stand Alone - Not Interchangeable:



HM46780

HM46780
Stainless steel filter, 38 μ m, \varnothing 20 mm

19858HM
Membrane filter tube set (5 pcs)
HMP42 probe,
0.2 μ m, \varnothing 4mm

19867HM
Steel grid for the HMP42 probe,
1 mm, \varnothing 4 mm

VAISALA

Welcome to Vaisala Knowledge eNewsletter

OVERVIEW

Update your facts

Get the latest news about leading edge technology. Find out more about our existing application solutions, instrumentation and measurement practices.

» [Subscribe at www.vaisala.com/knowledge](http://www.vaisala.com/knowledge)

HVAC Measurement Spotlight

Learn about environmental measurement in HVAC systems. These articles deal with topics such as demand control ventilation, indoor air quality and good measurement practices. eNewsletters are available in English, German, French, and Chinese.



Life Science Spotlight

Get information about instrumentation and measurement in controlled environments such as cleanrooms & dryrooms, laboratories, incubators, environmental test chambers, warehouses and other critical environments. Topics include humidity monitoring in cleanrooms or test chambers, CO₂ monitoring in incubators and more. eNewsletters are available in English, German, French, Chinese, and Japanese.



Industrial Measurement Spotlight

Industrial processes such as air drying, lubricating oil management, and power production require rigorous measurements in extreme conditions. These articles deal with topics such as measuring moisture in oil, compressed air quality, and more. eNewsletters are available in English, German, French, Chinese, and Japanese.



What's New Spotlight

Be one of the first to know about new instruments, new application solutions and new company developments at Vaisala. eNewsletters are available in English, German, French, Chinese, and Japanese.



Vaisala Contact Information

EUROPE

FINLAND

Vaisala Oyj
P.O.Box 26
FI-00421 Helsinki
FINLAND
Tel. +358 9 894 91
Fax +358 9 8949 2485
sales@vaisala.com
www.vaisala.com

BENELUX

Contact: Bonn Office
Adenauerallee 15
D-53111 Bonn
GERMANY
Tel. +49 228 24971 23
Fax +49 228 24971 11
Toll free Netherlands :
00800 -282 472 52
Toll free Belgium:
0800 17 200
benelux.sales@vaisala.com
www.vaisala.com

FRANCE

Vaisala SAS
Lyon Office
12, Avenue des Saules
F-69922 OULLINS Cedex
FRANCE
Tel. +33 4 72 68 80 54

+ 0800 67 67 26
ventes@vaisala.com
www.vaisala.fr

Vaisala SAS
Paris Office
2, rue Stéphenson
F-78181
Saint-Quentin-en-Yvelines
Cedex
FRANCE
Tel. +33 1 3057 7342
Fax. +33 1 3096 0858

+ 0800 67 67 26
ventes@vaisala.com
www.vaisala.fr

GERMANY

Vaisala GmbH
Bonn Office
Adenauerallee 15
D-53111 Bonn
GERMANY
Tel. +49 228 24971 0
Fax. +49 228 24971 11
National: 0800VAISALA
vertrieb@vaisala.com
www.vaisala.de

Vaisala GmbH
Hamburg Office
Schnackenburgallee 41D
D-22525 Hamburg
GERMANY
Tel. +49 40 83903 160
Fax. +49 40 83903 110
National: 0800VAISALA
vertrieb@vaisala.com
www.vaisala.de

Vaisala GmbH
Uhingen Office
Bahnhofstraße 3
D-73066 Uhingen
GERMANY
Tel. +49 7161 65494 40
Fax. +49 7161 65494 50
National: 0800VAISALA
vertrieb@vaisala.com
www.vaisala.de

SWEDEN

Vaisala Oyj
Malmö Office
Drottninggatan 1 D
S-212 11 Malmö
SWEDEN
Tel. +46 40 298 991
Fax +46 40 298 992
National (tel.): 0200 848 848
National (fax.): 0200 849 849
forsaljning@vaisala.com
www.vaisala.com

Vaisala Oyj
Stockholm Office
Johanneslundsvägen 2
S-194 61 Upplands Väsby
SWEDEN
Tel. +46 8 750 94 20
Fax. +46 200 8490 849
National (tel.): 0200 848 848
National (fax.): 0200 849 849
forsaljning@vaisala.com
www.vaisala.com

SWITZERLAND

Contact: Bonn Office
Adenauerallee 15
D-53111 Bonn
GERMANY
Tel. +49 228 24971 0
Fax. +49 228 24971 11
vertrieb@vaisala.com
www.vaisala.de

UNITED KINGDOM

Vaisala Ltd
Newmarket Office
2B, Hillside Business Park,
Kempson Way, Moreton Hall,
Bury St. Edmunds,
Suffolk IP32 7EA
UNITED KINGDOM
Tel. +44 1638 576 200
Fax +44 1638 576 240
uksales@vaisala.com
www.vaisala.com

Vaisala Ltd
Birmingham Office
Vaisala House
351 Bristol Road
Birmingham B5 7SW
UNITED KINGDOM
Tel. +44 121 683 1257
Fax +44 1638 576 240
uksales@vaisala.com
www.vaisala.com

NORTH AMERICA

Vaisala Inc.
Boston Office
10-D Gill Street
Woburn, MA 01801
USA
Tel. +1 781 933 4500
Toll free 1-888-VAISALA (824-7252)
Fax. +1 781 933 8029
instruments@vaisala.com
www.vaisala.com

Vaisala Inc.
Houston Office
1120 NASA Road, Suite 220-E
Houston, TX 77058,
USA
Tel. +1 281 335 9955
Fax. +1 281 335 9956
instruments@vaisala.com
www.vaisala.com

Vaisala Inc.
San Jose Office
6980 Santa Teresa Blvd.
San Jose, CA 95119-1393
USA
Tel. +1 408 578 3670
Toll free 1-888-VAISALA
(824-7252)
Fax: +1 408 578 3672
instruments@vaisala.com
www.vaisala.com

Vaisala Canada Inc
Vancouver Office
100-13775 Commerce Parkway
Richmond, BC V6V 2V4
CANADA
Tel. +1 604 273 6850
Toll free 1-800 683 8374
Fax: +1 604 273 2874
instruments@vaisala.com
www.vaisala.com

ASIA AND PACIFIC

AUSTRALIA

Vaisala Pty Ltd
Melbourne Office
3 Guest Street
Hawthorn, VIC 3122
AUSTRALIA
Tel: +61 3 9815 6700
Fax: +61 3 9815 6799
Freecall: 1800 335 840
sales.melbourne@
vaisala.com
www.vaisala.com

CHINA

Vaisala China Ltd
Beijing Office
Floor 2, EAS Building
No.21, Xiao Yun Road,
Chaoyang District
100027, Beijing
CHINA
Tel. +86 10 5827 4100
Fax. +86 10 8526 1155
chinasales@vaisala.com
cn.vaisala.com

Vaisala China Ltd
Shanghai Branch
Room 1102, Information Tower
No. 1403 Minsheng Road
Pudong New District
200135 Shanghai
CHINA
Tel. +86 21 50111581/2/3
Fax. +86 21 50111580
chinasales@vaisala.com
cn.vaisala.com

Vaisala China Ltd
Shenzhen Branch
Bldg 1, 17B China Phoenix Building
2008 Shennan Avenue
Futian District 518026
Shenzhen
CHINA
Tel. +86 755 82792403
Fax. +86 755 82792404
chinasales@vaisala.com
cn.vaisala.com

JAPAN

Vaisala KK
Tokyo Office
42 Kagurazaka 6-Chome
Shinjuku-Ku
Tokyo 162-0825
JAPAN
Tel. + 81 3 3266 9611
Fax. + 81 3 3266 9610
sales.japan@vaisala.com
www.vaisala.co.jp

Calculate and Convert.

The free web based Vaisala Humidity Calculator allows you to calculate several humidity parameters from one known humidity value. Make unit conversions on the fly, and see the effects of changing ambient conditions, like temperature and pressure. The calculator is available in several languages.

Access or download the Vaisala Humidity Calculator at www.vaisala.com/humiditycalculator

VAISALA Humidity Calculator 3.1		
Language: EN FR DE ES PT IT RU CN JP KR TW TH VI IN BR AR PL UK UA HE HI ID SV NO DA NL SE FI PT BR AR PL UK UA HE HI ID SV NO DA NL SE FI		
Ambient Conditions		
Temperature	23	Unit Conversion
Pressure	1013.25	Unit Conversion
Gas type	Air	Add New
Humidity	Relative	Add New
Fill in the known parameter to calculate other values		
Absolute humidity (g/m ³)		Unit Conversion
Dewpoint		Unit Conversion
Saturation vapor pressure (kPa)		Unit Conversion
Absolute humidity (kg)		Unit Conversion
Saturated vapor (g)		Unit Conversion
Saturated vapor (kg)		Unit Conversion
Saturated vapor (kg)		Unit Conversion
Saturated vapor pressure (kPa)		Unit Conversion
Water gain		Unit Conversion
Saturation vapor pressure (kPa)		Unit Conversion
<input type="button" value="Calculate"/> <input type="button" value="Reset"/> <input type="button" value="Print"/>		

Available also at the Apple iTunes App Store



www.vaisala.com/humiditycalculator

VAISALA

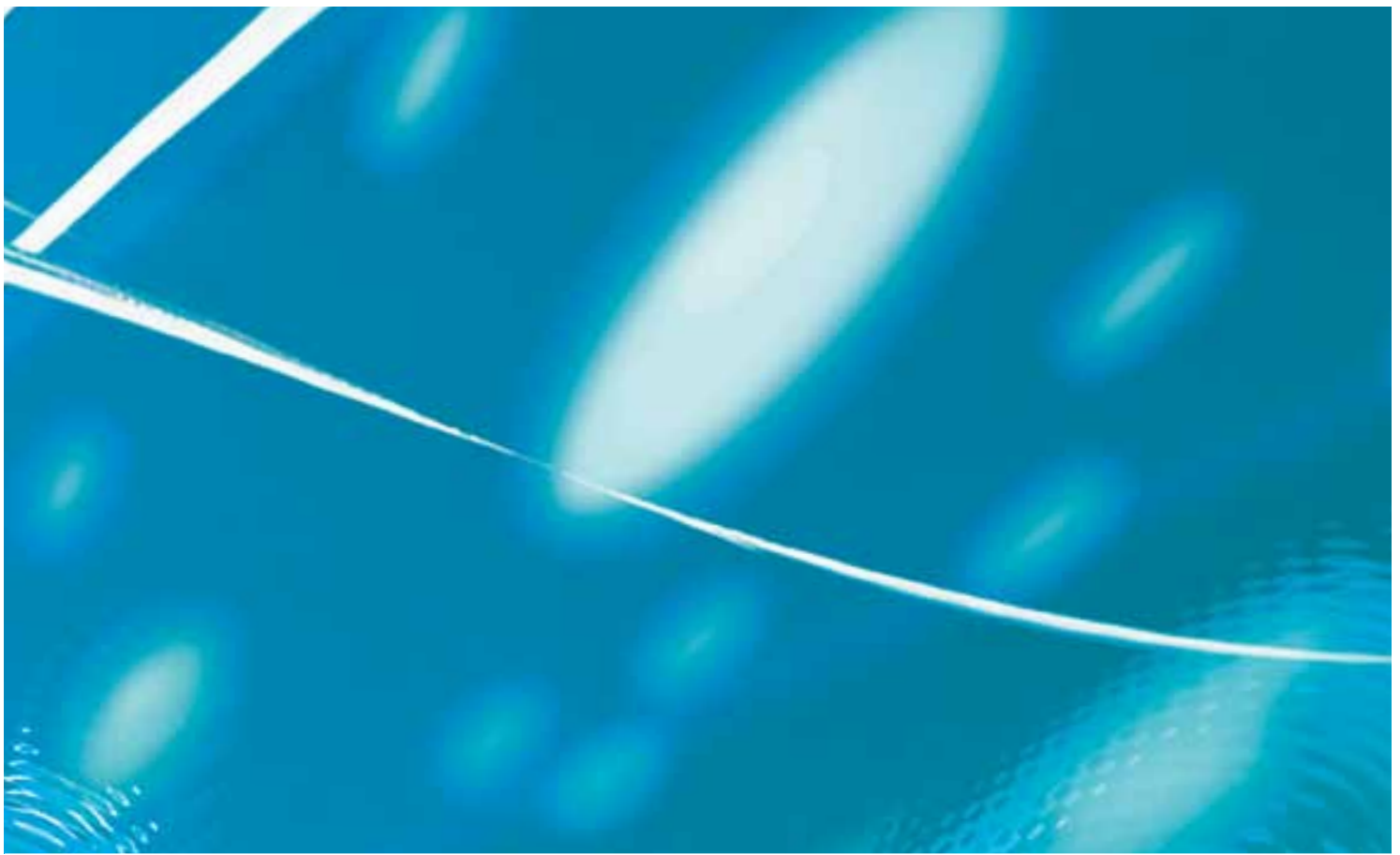

VAISALA

www.vaisala.com

For more information, visit www.vaisala.com or contact us at sales@vaisala.com

Ref. B210974EN-C ©Vaisala 2012
This material is subject to copyright protection, with all copyrights retained by Vaisala and its individual partners. All rights reserved. Any logos and/or product names are trademarks of Vaisala or its individual partners. The reproduction, transfer, distribution or storage of information contained in this brochure in any form without the prior written consent of Vaisala is strictly prohibited. All specifications — technical included — are subject to change without notice.