

DMT143 Miniature Dewpoint Transmitter for OEM Applications



The Vaisala DRYCAP® Dewpoint Transmitter DMT143 is an ideal choice for small compressed air dryers, plastic dryers and other OEM applications.

Vaisala DRYCAP®

The Vaisala DRYCAP® Dewpoint Transmitter DMT143 is a miniature dew point measurement instrument. The transmitter can be installed directly into pressurized systems at 50 bar (725 psia) maximum pressure. The long-term high performance is achieved with Vaisala DRYCAP® technology.

The sensor fully withstands getting wet, and therefore, the transmitter performs exceptionally well in applications that occasionally experience process water spikes, such as pipeline condensation during a system failure or start-up. The sensor is also highly resistant to particulate contamination, oil vapor and most chemicals, and is insensitive to the flow rate.

Long Calibration Interval

The calibration interval of the DMT143 is two years. Additionally, the Vaisala

DRYCAP® Hand-Held Dewpoint Meter DM70 can be used to confirm the performance of the DMT143 without disconnecting the transmitter. For any adjustment needs, the transmitter can be sent to Vaisala Service.

The auto-calibration software works on-line while the process is running. If the measurement accuracy is not confirmed, corrections are made automatically.

Technical Data

Measured Parameters

DEW POINT TEMPERATURE	
Measurement range(typical)	-60 ...+60 °C (-76 ...+140 °F) T _d
Analogue output scalings	
option 1	-80 ...+20 °C (-112 ...+68 °F) T _d
option 2	-80 ...+20 °C (-112 ...+68 °F) T _d dew point at ambient pressure
option 3	free scaling
Accuracy in air or N ₂	±2 °C (±3.6 °F) T _d (see graph below)
when the dew point is below 0 °C (32 °F), the transmitter outputs frostpoint	

Features/Benefits

- Miniature size dew point transmitter for e.g. small industrial dryer applications
- Vaisala DRYCAP® technology with auto-calibration
- Calibration interval of two years
- Dew point measurement range -60...+60 °C (-76...+140 °F)
- Accuracy ±2 °C (±3.6 °F)
- Withstands condensation
- Fast response time
- Compatible with Vaisala DRYCAP® Hand-Held Dewpoint Meter DM70
- NIST traceable calibration (certificate included)
- Easy servicing and data transfer via the RS485 user interface
- LED alarm for exceeded dew point level

Easy Installation

The DMT143 has a variety of features to choose from, including different output, installation options and alarm LED.

Due to its small size and light weight, the DMT143 is quickly and easily installed in tight spaces or in small-size pipelines. The alarm LED indicates too high dew point in the process. The trigger point is preset at the factory. It can be later adjusted with the Vaisala DRYCAP® Hand-Held Dewpoint Meter DM70 or a PC.

Technical Data

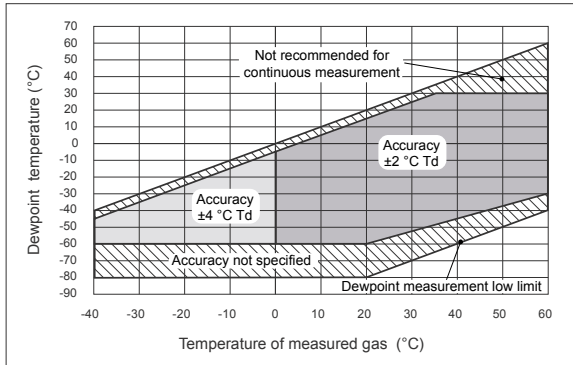

Dew point accuracy vs. measurement conditions

Response time 63% [90%] at +20 °C gas temperature and 1 bar pressure

-60 → -20 °C T _d (-76 → -4 °F T _d)	5 s [15 s]
-20 → -60 °C T _d (-4 → -76 °F T _d)	45 s [10 min]

PPM VOLUME CONCENTRATION

Measurement range (typical)	10 ... 40000 ppm
Accuracy at +20 °C (+68 °F), 1 bar	1 ppm + 20% of reading

Operating Environment

Measured gases	non-corrosive gases
Temperature *)	-40 ... +60 °C (-40 ... +140 °F)
Relative humidity	0 ... 100 %RH
Pressure *)	0 ... 50 bar _a (725 psia)
Sample flow rate	no effect for measurement accuracy

*) For extended temperature down to -40 °C (-40 °F) or pressure up to 50 bar_a (725 psia) the supply voltage must be 24 ... 28 VDC.

Outputs

Analog output (scalable)	4 ... 20 mA (3-wire), 0 ... 1 V/5 V, 1 ... 5 V
Resolution for current output	0.002 mA
Resolution for voltage output	0.3 mV
Typical temperature dependence	0.005 % of span / °C
Digital output	RS-485, non-isolated
	Vaisala Industrial Protocol
Connector	4-pin M8 (IEC 60947-5-2)

General

Sensor	Vaisala DRYCAP® 180D
Recommended calibration interval to confirm the specified accuracy	2 years
Operating voltage with voltage output	12 ... 28 VDC
Operating voltage with current output	18 ... 28 VDC

Supply current

normal measurement	max 10mA + load current
during self-diagnostics	max. 220 mA pulsed
Load for current output	max. 500 Ohm
Load for voltage output	min. 10 kOhm
Housing material	stainless steel (AISI316L)
Sensor protection	stainless steel sintered filter
Mechanical connection	ISO G1/2" or NPT 1/2
Housing classification	IP66 (NEMA 4)
Storage temperature range	-40 ... +60 °C (-40 ... +140 °F)
Weight	G-thread version 90g (3.2oz) NPT-thread version 100g (3.5oz)

Complies with EMC standard EN61326-1, Electrical equipment for measurement, control and laboratory use - EMC requirements - Industrial environment.

Accessories

Connection cable for DM70	219980SP
USB connection cable	219690
Sampling cells	
basic sampling cell	DMT242SC
with Swagelok 1/4" male connectors	DMT242SC2
with quick connector and leak screw	DSC74SP
two-pressure sampling cell	DSC74BSP
cooling/venting coil	DMCOILSP

See DM70 / Portable Sampling Systems and Sampling Cells for further information about sampling cells available

Loop powered external display	226476
Loop powered external display with relays	234759

Dimensions

in mm

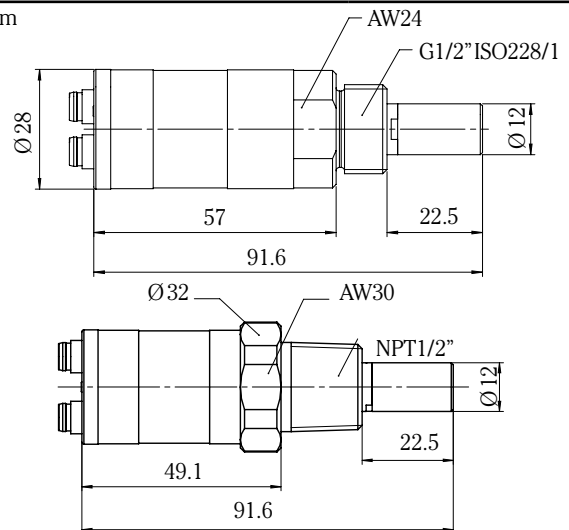

VAISALA

www.esis.com.au
 Ph 02 9481 7420
 Fax 02 9481 7267
esis.enq@esis.com.au

Ref. B211207EN-B ©Vaisala 2012
 This material is subject to copyright protection, with all copyrights retained by Vaisala and its individual partners. All rights reserved. Any logos and/or product names are trademarks of Vaisala or its individual partners. The reproduction, transfer, distribution or storage of information contained in this brochure in any form without the prior written consent of Vaisala is strictly prohibited. All specifications — technical included — are subject to change without notice.

