

HMM105 Digital Humidity Module for OEM Applications



The Vaisala HUMICAP® Digital Humidity Module HMM105.

Features/Benefits

- Digital I²C communication interface available
- Full temperature compensation over the operating temperature range of -40 °C...+180 °C
- High temperature tolerance, suitable for heat sterilization up to +200 °C
- Excellent measurement accuracy with Vaisala HUMICAP® 180R sensor
- Maintenance-free
- Detachable probe assembly for easy installation
- Probe head with M10x1 threads
- 2-point NIST traceable calibration (certificate included)
- Applications: test chambers, incubators

The Vaisala HUMICAP® Digital Humidity Module HMM105 is an open frame module for integration into environmental chambers. The modules provide an I²C output for relative humidity (RH) or dew point (T_d). The module consists of a detachable probe assembly – a probe head with M10x1 threads and a flex cable – and the module circuit board. The probe assembly is 30 cm in length. The module incorporates the Vaisala HUMICAP® 180R sensor which ensures excellent measurement accuracy.

Reliable for OEM's

The HMM105 probe head works in freezing conditions (-40 °C) and also in temperatures up to +180 °C in continuous use. In short term use, the probe head can be exposed to temperatures up to +200 °C. The HMM105 is intended

for OEM chamber manufacturers for integration into test chambers and incubators.

Maintenance-free

Compared to psychrometers, the HMM105 is practically maintenance free. There is no wick that needs changing and there is no need for a water tank or water pump. Thus, environmental stress screening can be done reliably.

I²C interface for better usability

The HMM105 has an I²C interface for communicating with the incubator's controller. The HMM105 implements I²C slave functionality, with the incubator's controller acting as the master. The interface can be used to read measurement values and status information, set operation parameters, and make adjustments.

Technical Data

Performance

RELATIVE HUMIDITY	
Measurement range	0 ... 100 %RH
Accuracy (incl. non-linearity, hysteresis and repeatability)	
temperature range	-20 ... +40 °C
0 ... 90 %RH	±2 %RH
90 ... 100 %RH	±3 %RH
temperature range	-40 ... -20 °C, +40 ... +180 °C
0 ... 90 %RH	±2.5 %RH
90 ... 100 %RH	±3.5 %RH
Factory calibration uncertainty (+20 °C)	±1.5 %RH
Humidity sensor	Vaisala HUMICAP® 180R

DEW POINT TEMPERATURE	
Measurement range	-20 ... +100 °C (-4 ... +212 °F) _{T_d}
Accuracy (incl. non-linearity, hysteresis and repeatability when dew point depression <20 °C)	±2 °C T _d
(Ambient temperature - dew point)	

Operating Environment

Operating temperature range	
component board	-5 ... +55 °C (+23 ... +131 °F)
probe (continuous use)	-40 ... +180 °C (-40 ... +356 °F)
probe (short term peak)	+200 °C (+392 °F)
PTFE sintered filters, stainless steel	
sintered filter	-40 ... +200 °C (-40 ... +392 °F)
plastic grid, membrane filter	-20 ... +80 °C (-4 ... +176 °F)
Storage temperature	-40 ... +75 °C (-40 ... +167 °F)
Electromagnetic compatibility	Applicable parts of EN61326-1, Industrial Environment

Input and Outputs

Supply voltage	10 ... 35 VDC, 24 VAC (±20 %)
Output	I ² C 5 V
Power consumption (DC/AC)	<15/25 mA
Connector for supply voltage and I ² C bus	Molex 87832-1007, 10-pin header

Mechanics

Probe diameter	12 mm
Probe flex cable length	0.3 m
Probe lead-through material	PPS plastic

Options and Accessories

Humidity sensor	HUMICAP180R
Short PTFE sintered filter	DRW239993SP
Plastic grid filter	6221
Plastic grid and membrane filter	10159HM
PTFE sintered filter	219452SP
Stainless steel sintered filter	HM47280SP
0.6 m cable with Molex milli-grid connectors	ASM210962SP

Dimensions

Dimensions in mm

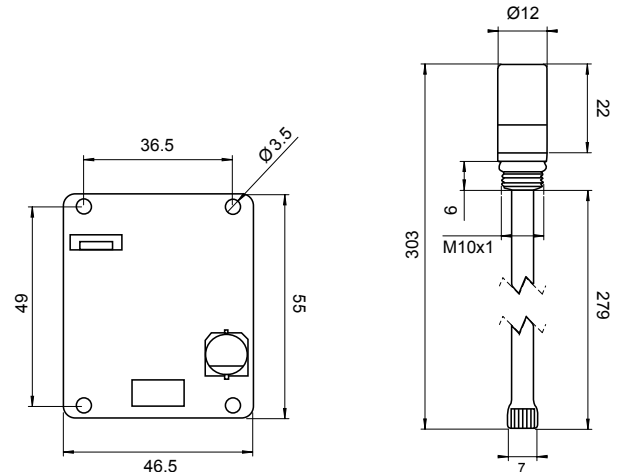

VAISALA



www.esis.com.au
 Ph 02 9481 7420
 Fax 02 9481 7267
esis.enq@esis.com.au

Industrial Electronics

Ref. B211377EN-A ©Vaisala 2014
 This material is subject to copyright protection, with all copyrights retained by Vaisala and its individual partners. All rights reserved. Any logos and/or product names are trademarks of Vaisala or its individual partners. The reproduction, transfer, distribution or storage of information contained in this brochure in any form without the prior written consent of Vaisala is strictly prohibited. All specifications — technical included — are subject to change without notice.

