

50A HIGH PERFORMANCE MINI CURRENT TRANSFORMERS



The hinged "Mini" CTs are small, low-cost current transformers with high accuracy (<0.5%) over a wide dynamic range with excellent phase shift. The "Minis" are ideal where space is limited such as when metering multiple loads within a panel board. Use for current measurement, energy metering, load surveys, demand metering, energy research, and submetering.

KEY SPECIFICATIONS

Window Size	0.4" (10 mm)
Current Range*	0.25 - 80A AC
Output	333 mV @ 50 A AC 6.66 mV/A AC
Ratio Error**	<0.5% from 0.25 to 80A AC (typical)
Phase Error	<1.5° from 1 to 80A AC <2° From 0.25 to 1A AC

* Depending on meter compatibility. See ELITEpro™ and PowerScout™ specifications for details.
** For maximum performance, keep CT contact surfaces wiped clean and free of debris.

ELECTRICAL

Output	333 mV @ 50 A
Wire Polarity	White = Hi, positive (+) Black = Low, negative (-)
Phasing	Arrow On Case Points
Orientation	Toward Load
Frequency Range	50 to 400 Hz

MECHANICAL

Case Material	White Nylon, UL 94 V-0
Leads	2.4 M (8'), 600V, 20 gage
Working Temperature	-15 to 60°C (5 to 140°F)

SAFETY

Working Voltage	600 VAC, Category III
Dielectric Strength	3520 VAC for 1 minute
Certification	Conforms to: UL STD 61010-1 Certified to: CAN/CSA STD C22.2 No. 61010-1



PART NUMBERS

CT-HSC-050-U	Crimp ferrules on leads
CT-HSC-050-B	With Banana Plugs (for use with Weather-tight PRO-series Instruments)

CONTACT US

DENT Instr
Energy & Power

www.esis.com.au
Ph 02 9481 7420
Fax 02 9481 7267
esis.enq@esis.com.au

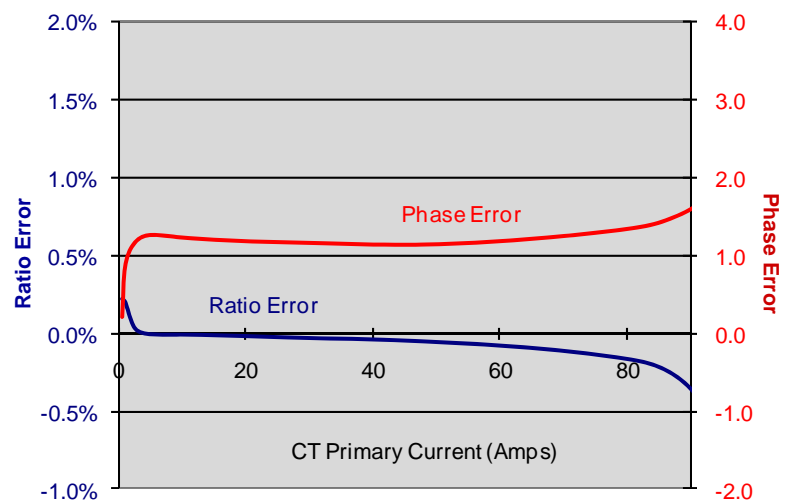
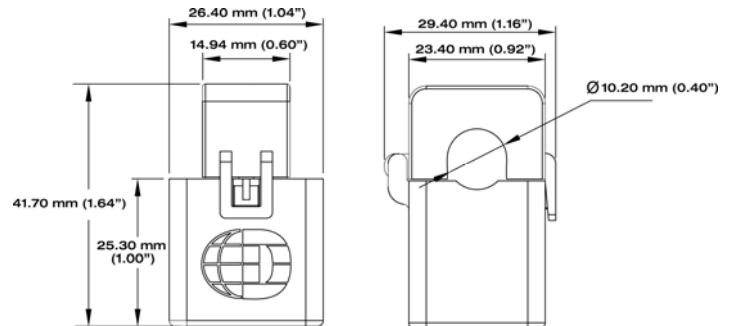
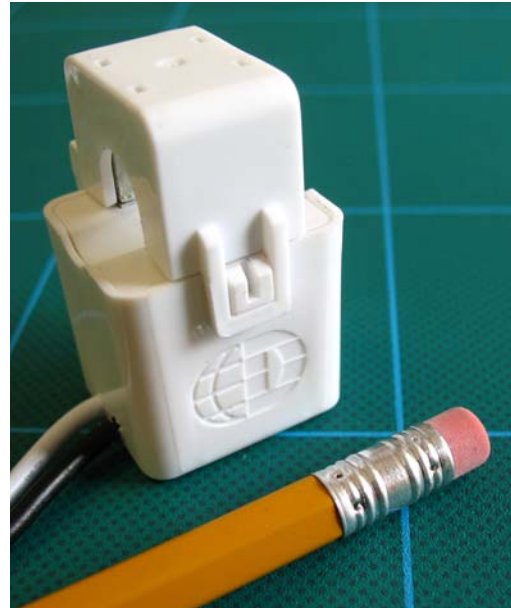

All specifications contained in this document are subject to change without notice.
© DENT INSTRUMENTS, INC.
rev 062712