

VAISALA

DSS70A Portable Sampling System and Sampling Cells for DM70



Features

- Battery-powered pump for extracting gas samples
- Five sampling cell options for gas sampling
- Filter for removing particulate contamination before measurement
- Needle valve and flow meter for controlling and monitoring flow through the system
- Connectable to pressurized processes

DSS70A provides a compact solution for field checking dew point where direct measurement is difficult. Typical applications for the sampling system are metal treatment and plastics drying processes.

DSS70A Portable Sampling System

DSS70A is designed to provide dew point sampling flexibility for the DM70 hand-held dew point meter. For processes at atmospheric pressure, a battery powered pump is used to extract a gas sample. For pressurized processes up to 20 bar, the sample is measured at process pressure and then reduced to atmospheric pressure for venting or re-direction, bypassing the pump. In all cases, the sample gas passes through a filter to remove particulate contamination before measurement. Flow through the system is controlled and monitored with a needle valve and flow meter. DSS70A is easily connected to an appropriate sample point with tubing (typically 1/4" or 6 mm). The measured dew point must be below ambient temperature to avoid condensation in the system. Gas temperatures higher

than +40 °C (+104 °F) should be cooled with a short PTFE (included in the DSS70A system) or stainless steel tube prior to entering DSS70A. DSS70A is an accessory for DM70 Dewpoint Handheld Meter.

Sampling Cells for Pressurized Processes

DM70 can easily be connected to pressurized processes. In addition to direct pipeline installation, a variety of sampling cell options are available for gas sampling.

DSC74 sampling cell is the recommended choice. It has a variety of connection adapters that allow several different ways of installation. The quick connector with a leak screw allows a very fast connection for compressed air lines. Additionally, two thread adapters are available for the inlet port.

DSC74B is a two-pressure sampling cell, which enables measurements in both process and ambient pressure. This sampling cell is especially suitable for dew point measurements in SF6 gas with the DMP74C probe.

DMT242SC is a basic sampling cell. DMT242SC2 is a sampling cell supplied with welded Swagelok connectors for sampling in a 1/4" pipeline.

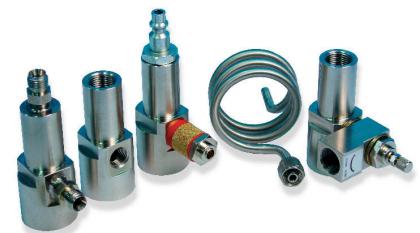

The sampling cells (from the left) DMT242SC2, DMT242SC and DSC74 can be used to connect the DM70 to sample gas flow. The DSC74B (right) is a two-pressure sampling cell that can be used for measurements in either pressurized or ambient pressure. The cooling/venting coil is included in the DSC74C sample cell, but is an option for all sampling cells.

Technical Data

DSS70A Sampling System and DSC74B/C Sampling Cells

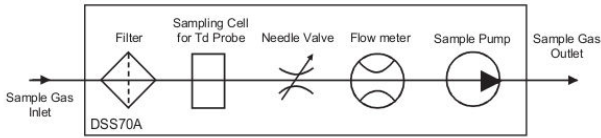

The DSS70A sampling system includes a filter to clean the dirty sample gas and a needle valve to control the sample flow rate with the flow meter. A sample pump is used to generate a sample flow from processes at ambient pressure.

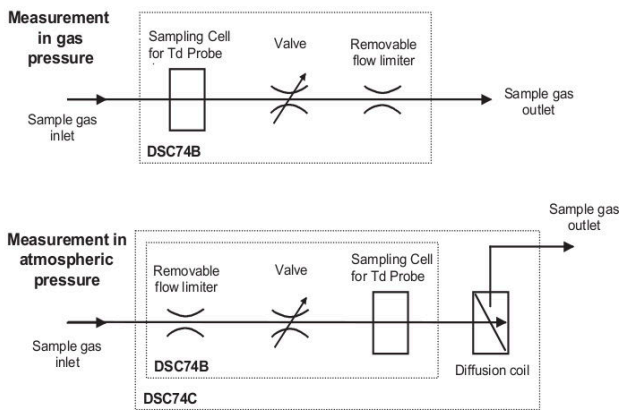

The DSC74B sampling cell enables the measurement of the sampled gas either in gas pressure up to 10 bar or in atmospheric pressure depending on the gas inlet and outlet. DSC74C is like DSC74B but with an additional coil to avoid back diffusion, the effect of surrounding moisture, in dew point measurements in atmospheric pressure.

DSS70A Operating Environment

Operating gases	Air, N ₂ , and other non-toxic, inert gases
Sampled gas dew point	Below Tamb
Inlet/outlet connection	1/4" Swagelok
Operating ambient temperature	0 ... +40 °C (+32 ... +104 °F)
Operating process gas temperature with PTFE tube at +20 °C (+68 °F) (included in the DSS70A)	Max. +200 °C (+392 °F)
Operating temperature with stainless steel tube	Specification according to stainless steel tube specification
Maximum gas temperature at inlet	+40 °C (+104 °F)
Operating pressure with pump	0.6 ... 1.2 bara (8.7 ... 17.4 psia)
Operating pressure with pump disconnected	0 ... 20 bara (0 ... 290 psia)

Mechanical Specifications

Battery operation time for pump	8 h continuous use (battery can be recharged using DM70 charger)
---------------------------------	---

Filter	7 mm inline filter cartridge 1/4" Swagelok SS-4F-7 (spare part order no. 210801)
--------	--

Case dimensions (W × D × H)	430 × 330 × 100 mm
-----------------------------	--------------------

Weight	5.5 kg (12 lbs)
--------	-----------------

Materials	
Wetted parts	Stainless steel
Carrying case	ABS plastic

Sampling Cell Options

DSC74	Sampling cell for pressurized gases
DSC74 pressure limit	1 MPa (10 barg, 145 psig)
DSC74B	Two pressure sampling cell
DSC74B pressure limit	1 MPa (10 barg, 145 psig)
DSC74C	DSC74B with DMCOIL cooling/venting coil
DMCOIL	Cooling/venting coil
DMT242SC	Sampling cell
DMT242SC pressure limit	10 MPa (100 barg, 1450 psig)
DMT242SC2	Sampling cell with Swagelok connectors
DMT242SC2 pressure limit	4 MPa (40 barg, 580 psig)
Material for all sampling cells	Stainless steel AISI316

Compliance

EMC	EN61326-1, Generic Environment
-----	--------------------------------

