



- » Supports IEC61131-3 programming
- » LD, FBD, ST, SFC, IL languages
- » 0.06 μ s per contact
- » Power remote display

FL005 (Expandable Series)

Salient Features

- DIN rail / Back panel mounted PLC
- Transistor or Relay outputs
- Expandable up to 16 expansions
- 32 Bit RISC processor
- Built-in RTC
- DC inputs, DC Outputs
- Analog Inputs (Voltage, Current, RTD and Thermocouple)
- Analog Output (Voltage, Current)
- Support for High Speed Counters / Quadrature (up to 200 KHz) and Timers
- High Speed PWM output (200 KHz)
- Up-to 2 Serial Ports. Support for various PLC protocols
- 1 USB Device Port
- DC powered units (24 V DC)
- Simple Ladder programming using Windows[®] based software
- Support for LD, FBD, ST, SFC, IL type IEC61131-3 programming languages
- CE, UL Class1 Div2 approved

Model Description

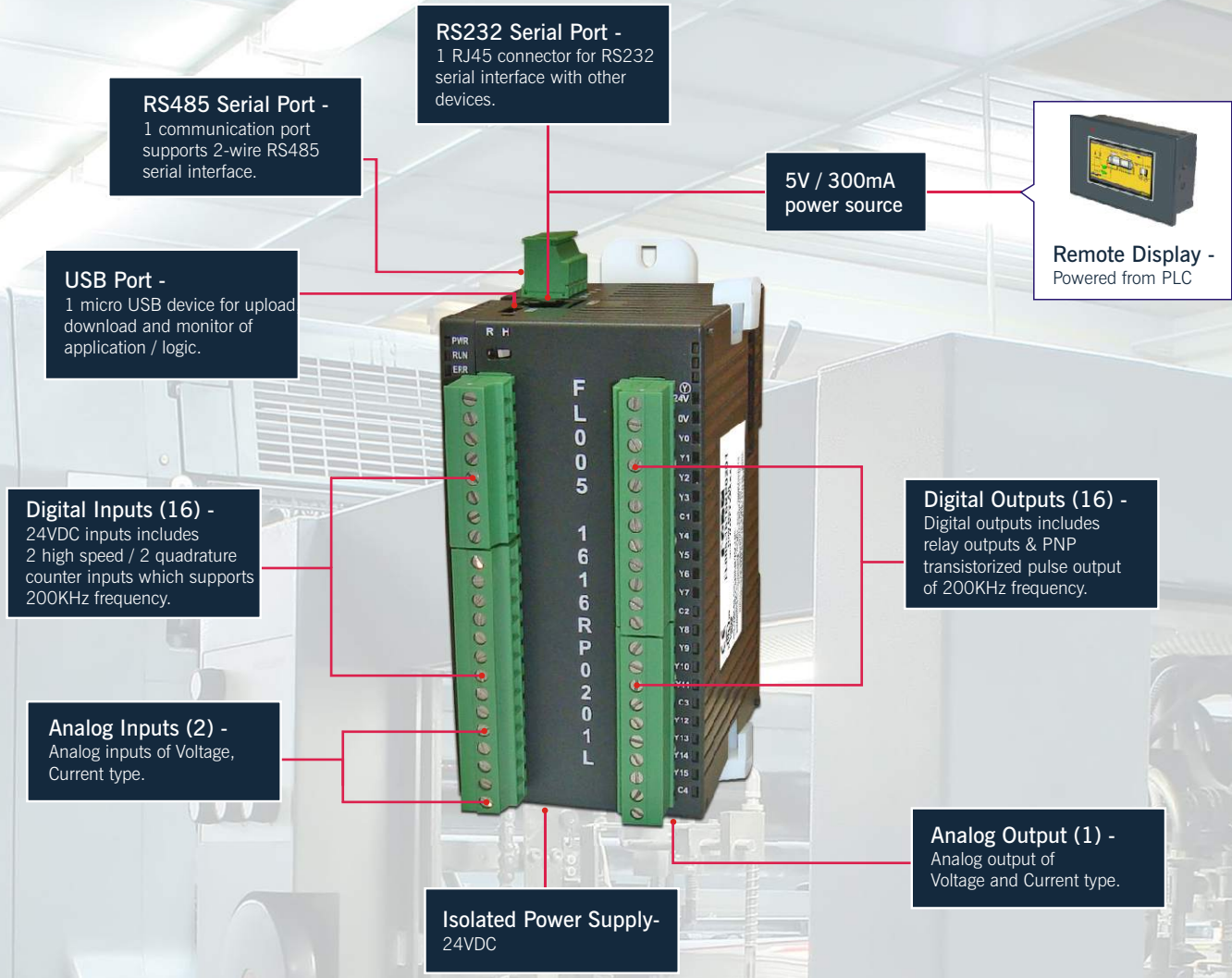

Greater Expandability - Up-to 16 Expansions

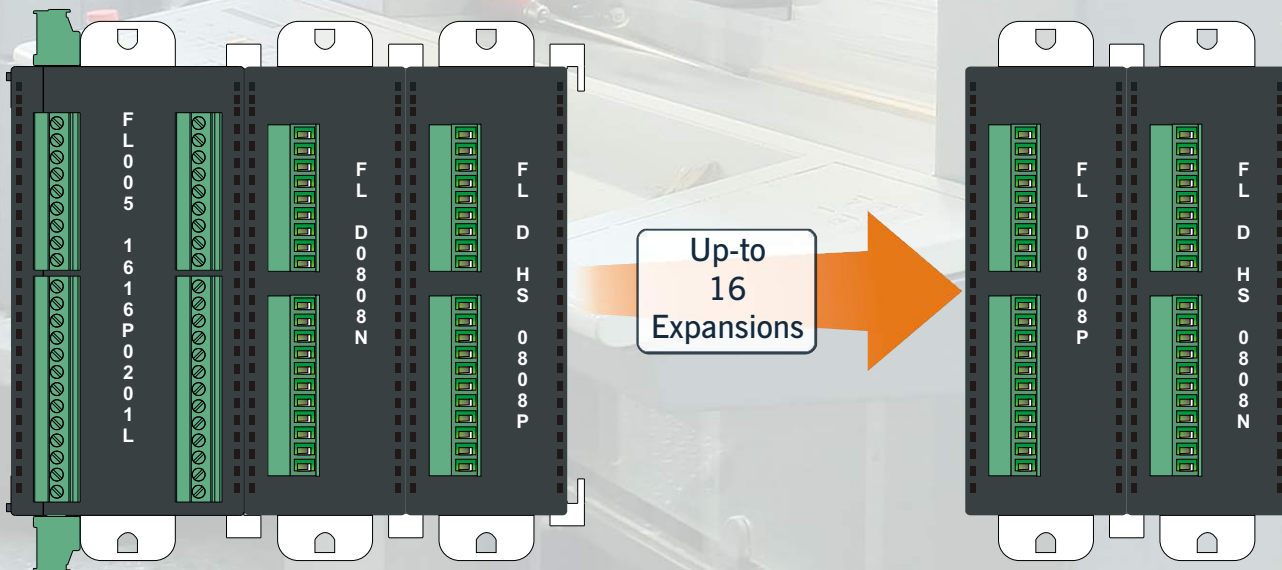

Software Features

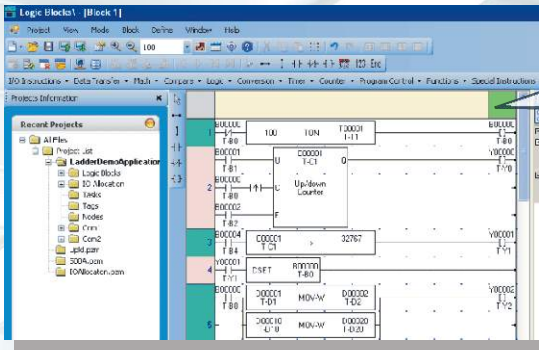

Configuration Software FlexiSoft® is a compact, Windows® based software to configure the PLC. Following image from FlexiSoft® shows the snap shot of ladder configuration window:

IEC61131-3 Programming Environment Create application using LD language

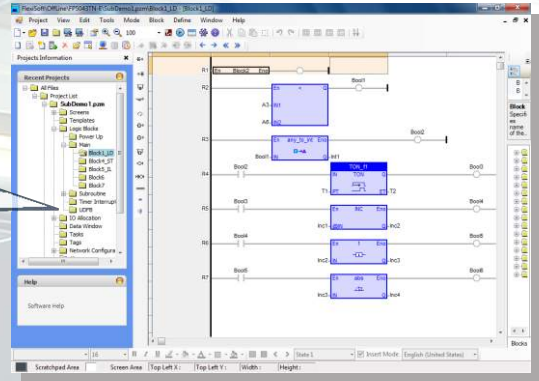

IEC61131-3 Programming Environment Create application using FBD language

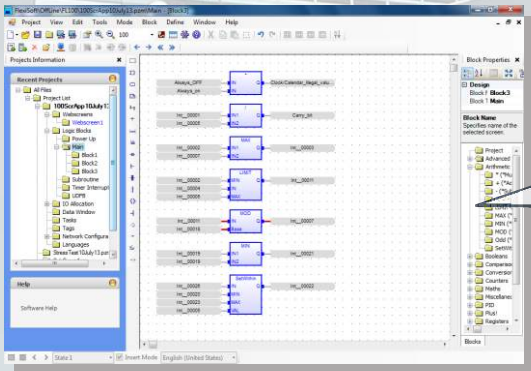

IEC61131-3 Programming Environment Create application using IL language

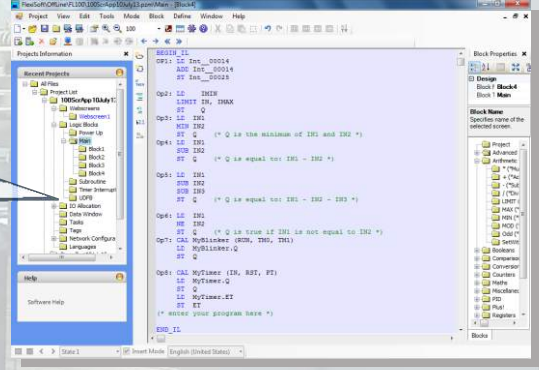

IEC61131-3 Programming Environment Create application using ST language

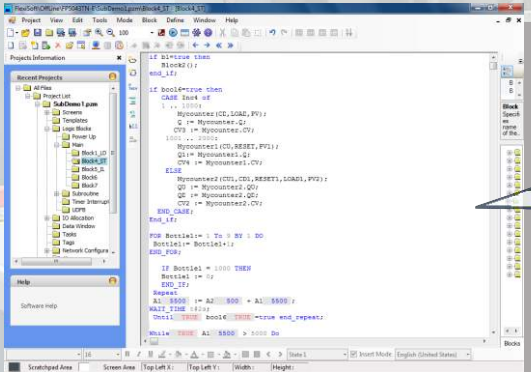

IEC61131-3 Programming Environment Create application using SFC language

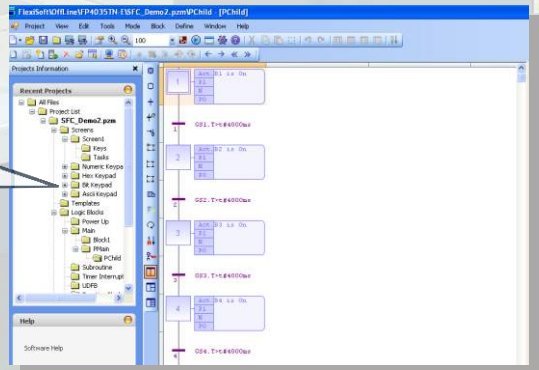

- System requirements for FlexiSoft® Software are -
- Windows Version : Microsoft Windows® 2000 or above
 - Processor : 266 MHz PENTIUM or higher
 - Mouse : Required
 - RAM : 64 MB or more
 - Display resolution : 800 x 600 (VGA) or better
 - Display colors : 256 colors minimum
 - Serial Port : 1 serial port for FlexiPanels® programming
 - USB Port : 1 USB port (Host) for FlexiPanels® programming
 - Keyboard : Required

Software Features

Comprehensive Instructions supported in FlexiLogics®:

Native Ladder Instructions -

Some of the supported Instructions in FlexiLogics® are listed below :

1. Math
Instructions such as ADD, Subtract, Multiply and Divide. These instructions could be Single word or Double word, signed or unsigned format.
2. Data compare
Instructions such as Less than, Greater than, Equal to, Less than or Equal to, Greater than or Equal to etc. are supported.
3. Data Transfer Instructions
Data transfer instruction supports word and double word operands, Multiplexer / demultiplexer instructions.
4. Data conversion
Data conversion such as hex to ASCII, ASCII to hex, Binary, BCD, 2's Compliment, 7 segment etc. are possible.
5. Shift / Rotate
Rotate left, Rotate Right, Shift Left, Shift Right for word / double word.
6. I/O Instructions
Normally Open / Normally Closed contacts, positive pulse contact, negative pulse contact, Leading / Falling edge etc. are implemented.
7. Immediate I/O instruction
This instruction can be used to sample instantaneous physical inputs and outputs in PLC ladder.
8. Set / Reset
Coil / Bit / Register Set / Reset Instructions are supported.
9. Program Control
FlexiLogics® also support subroutine call, MCS / MCR, JCS / JCR, Enable / Disable Interrupts and step sequence instructions.
10. Functions
The function instructions like Moving average, Digital filter, Function generator, PID , Encode / Decode, Min / Max / Average Value, Lower / Upper Limit, Flip Flop are also supported.
11. High speed input and PWM Output
FlexiLogics® base module supports 2 high speed inputs up-to 200KHz. User can define 2 inputs of the base module (IP1 and IP3) for High speed application. The base module also supports PWM output up-to 100KHz.

Some of the supported IEC 61131-3 instructions are listed below:

1. Advanced-
Instructions such as Alarm_A, Alarm_M, Average, Derivate, Hyster ,RAMP etc .are supported.
2. Arithmetic-
Instructions such as Multiply .Divide, Addition Substraction, MOD etc .are supported.
3. Booleans-
Boolean And, F_TRIG, OR, FlipFlop, R_TRIG, XOR etc .are supported.
4. Comparisons-
Less than ,Less or equal, Is not equal ,Greater than etc. are supported.
5. Conversions-
Conversions such as Any to bool, Any to dint, Any to int ,Any to real etc. are possible.
6. Counters-
CTD(Down Counter) ,CTU(UP Counter), TUD(Up-Down Counter), CTDr(Down counter with rising edge detection) ,CTUDr(UP/DOWN counter with rising edge detection) are supported.
7. Maths-
Abs, modR, root trunc, Trigonometric functions.
8. Miscellaneous-
ActiveRTSwitch, EnableEvents are supported instructions.
9. PID-
PID instruction is supported.
10. Registers-
And_mask, Hibyte, Hiword, Lobbyte etc.
11. Selectors-
MUX, SEL, MUX4, MUX8.
12. Standard-
Instructions such as 1, DEC, INC, Neg etc are supported.
13. Timers-
Blink, PLS, TMD, TMU, TOF, TON etc. instructions are supported.
14. Strings-
Instructions such as ASCII, CONCAT, AtoH, Char, Mlen etc. are supported.

General Specifications

Functional	
Program Capacity	30K Steps
Total Program Memory	270KB (Application + Ladder)*
Execution Speed	60.0 ns / contact
	240.01 ns /coil
	373.35 ns/16 bit transfer
	366.68 ns/16 bit signed addition
Clock-Calendar	Year, month, day, hour, minute, second, & Day of the week

Environmental	
Temperature	0 to 55° C (operating), -20 to 85° C (storage)
Humidity	10 to 90 % non condensing
Vibration immunity	IEC60068-2-6
Shock immunity	IEC60068-2-27
Dimensions (mm)	100mm(H) X 52mm(W) X 70mm(D)
Isolation	Isolation between communication ports, power and I/O is 500 V DC for 1 Min.

#Additional retentive memory is 2.8KB.
Maximum 30000 EEPROM write cycles are allowed. Above this performance may degrade.

EMI/EMC	
Immunity to ESD	as per IEC61000-4-2
Immunity to Fast Transients	as per IEC61000-4-4
Immunity to Radiated electromagnetic field	as per IEC61000-4-3
Immunity to Conducted disturbances	as per IEC61000-4-6
Surge	as per IEC61000-4-5
Radiated emission	as per EN55011

Wiring Diagram

1. Digital Inputs

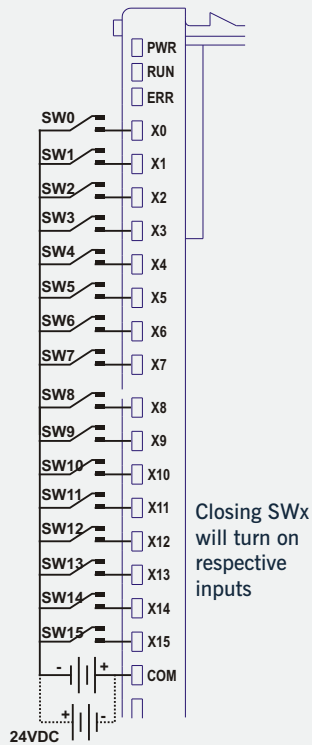

2. HSC Inputs

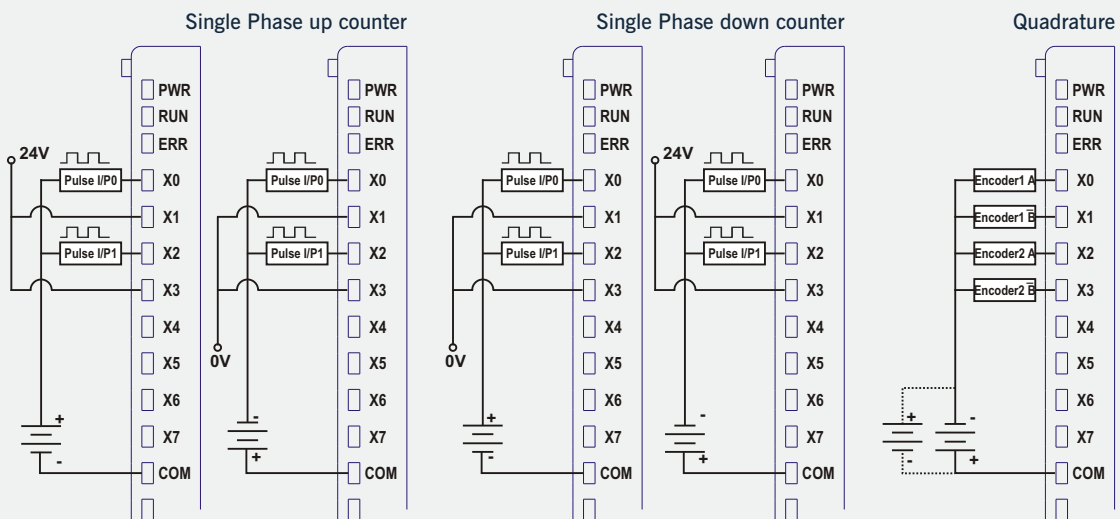

3. Digital Outputs

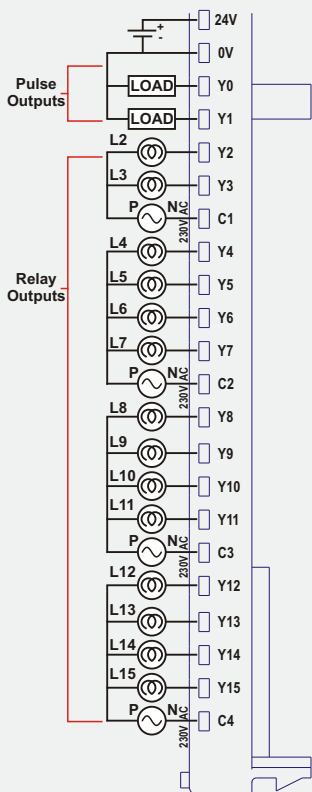

4. Analog Inputs and Outputs

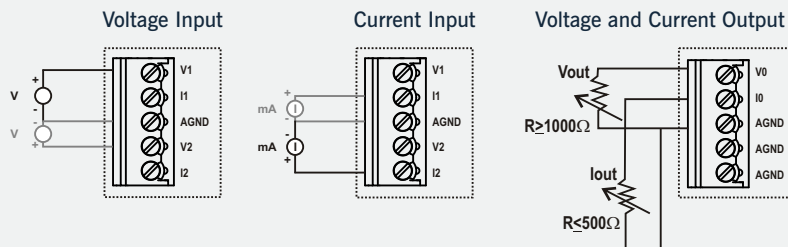

5. Analog Input / Outputs for FL005-0808RP0402U

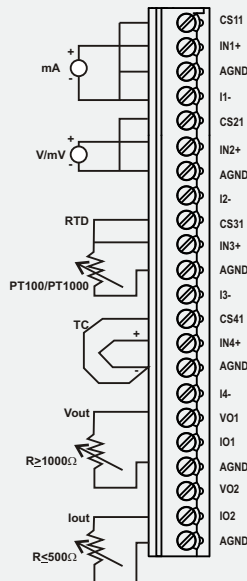

Protocols Supported for

PLC Based Control Application

Driver	FL005
ABB PLCs	✓
Allen Bradley DF1	✓
Aromat FP Series	✓
Baldor	✓
Danfoss Drive	✓
Delta PLCs	✓
Fatek PLCs	✓
FlexiLogics Slave Driver*	✓
GE SNP	✓
GE SNP- X	✓
Idec PLCs	✓
LG Master K Series PLC	✓
LG Master K 300S	✓
Mitsubishi FX	✓
Mitsubishi Q Series PLCs (Serial)	✓
Modbus ASCII (Unit as Master)	✓
Modbus RTU (Unit as Master)	✓
Modbus RTU (Unit as Slave)	✓
Omron Host Link	✓
Omron Inverter Memobus	✓
Serial Monitor*	✓
Serial Printer	✓
Siemens Gas analyzer (Master)	✓
Siemens micromaster driver (USS)	✓
Toshiba (Link Port) Series PLCs	✓
Toshiba Inverters PLCs	✓
Toshiba T Series	✓
TriPLC	✓
Twido PLCs	✓
Unitelway PLCs	✓
Universal Serial Driver(ASCII)	✓

*Supported with native programming environment

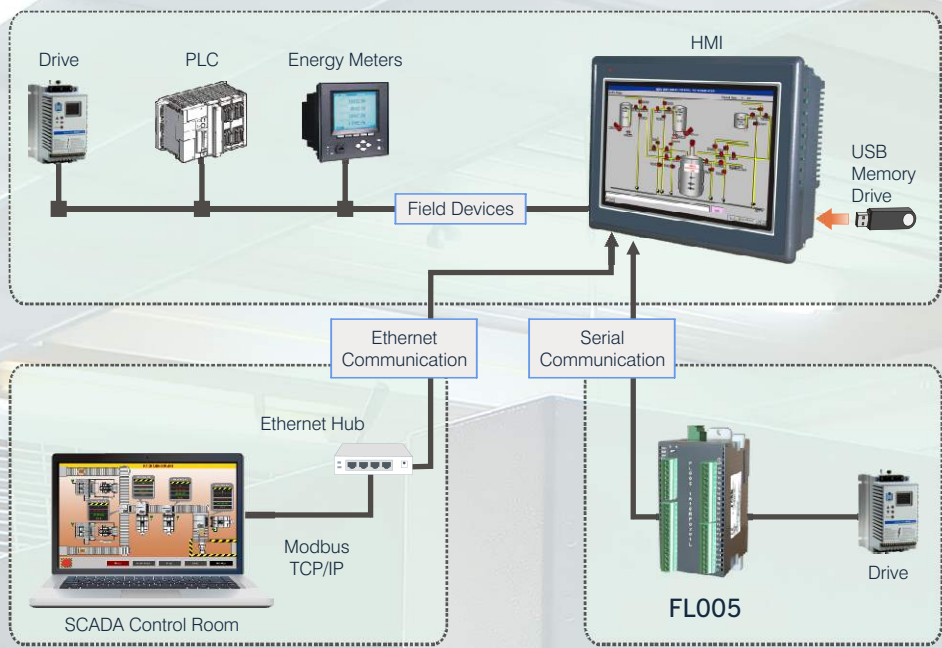

Expansion Models

Digital Expansion Modules

Model	Digital I/P	Digital O/P	Digital O/P
FLD1600	16	0	16 Digital Inputs
FLD0016P	0	16	16 Digital Outputs (PNP)
FLD0016N	0	16	16 Digital Outputs (NPN)
FLD0016R	0	16	16 Digital Outputs (Relay)
FLD0808P	8	8	8 Digital Inputs, 8 PNP type Transistor Outputs Digital module
FLD0808N	8	8	8 Digital Inputs, 8 NPN type Transistor Outputs Digital module
FLD0808R	8	8	8 Digital Inputs, 8 Relay type Outputs Digital module
FLD-HS-0808P	8	8	8 Digital Inputs, 8 Digital Outputs (PNP), 4 High Speed Inputs (Single phase & Quadrature counter), 2 PWM Outputs
FLD-HS-0808N	8	8	8 Digital Inputs, 8 Digital Outputs (NPN), 4 High Speed Inputs (Single phase & Quadrature counter), 2 PWM Outputs

Analog Expansion Modules

Model	Analog I/P	Analog O/P	Digital O/P
FLA0800L	8	0	8 Analog Inputs (0-10 VDC / 4-20 mA), 16 Bits
FLA0402U	4	2	4 Universal Inputs (0-10 V / 0-100 mV / 0-50 mV / 0-20 mA / 4-20 mA / RTD PT-100 / Thermocouple - B, R, S, E, J, K, N, T) 2 Analog Outputs (0-10 V / 4-20mA), 16 Bits
FLA0004	0	4	4 Analog Outputs (0-10 VDC / 4-20 mA), 16 Bits

N: Transistor output (NPN 500mA), R: Relay O/P, (6 Relay + 2 OC) P: PNP output (500mA)

Please contact factory for more information. We welcome an opportunity to develop new, custom drivers and customized units.

Dimensions

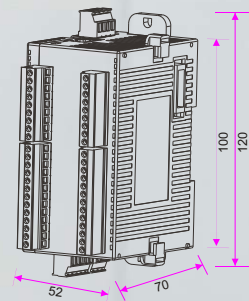

Fig. A
FlexiLogics® controller module

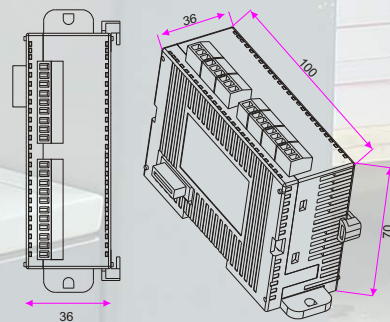

Fig B
FlexiLogics® expansion module

All dimensions are in mm.



HEAD OFFICE

ESIS
Industrial Electronics

www.esis.com.au
Ph 02 9481 7420
Fax 02 9481 7267
esis.enq@esis.com.au

website: www.renuelectronics.com

An ISO 9001:2008 and ISO 14001:2004 certified company

(Specifications subject to change without prior notice. DS-FL005-Expandable-Rev.G)