

FLEXIPANELS® - PC3 Series Windows CE Based HMI

The Window CE based FlexiPanels® have pre-installed Windows CE 6.0 R3 operating system. It allows the user to execute Windows CE compatible third party software, SCADA on the device. The SDK (software development kit) built for these devices can be used to develop native and managed custom applications, using VC++, VB, C# Languages and Visual Studio. .NET framework 3.5 is included in the device required to run managed applications on the device. These products can be connected to PC through USB cable and Active sync 3.5. USB Host can be used for connecting USB keyboard, USB Mouse and USB Stick.



SALIENT FEATURES

- ◆ 4.3", 7" and 10.2" Color TFT display options
- ◆ Pre-installed Windows CE 6.0 R3
- ◆ Flash: 128 MB
- ◆ RAM: 128 MB
- ◆ 2x serial communication ports
- ◆ 1x Ethernet port (10/100 Mbps)
- ◆ 1x SD card slot
- ◆ 1x USB device port
- ◆ 1x USB host port: Can be used for extended memory / USB keyboard / USB mouse
- ◆ Support for 65K color
- ◆ Front Panel mounting with IP66 rating
- ◆ CE, UL Class I Div 2, RoHS

MODEL SPECIFICATIONS

Model	PC3043TN	PC3070TN	PC3102TN
Display	4.3" WQVGA Color TFT	7" WVGA Color TFT	10.2" WVGA Color TFT
Resolution	480 x 272	800 x 480	800 x 480
Backlight	LED Backlight	LED Backlight	LED Backlight
CPU	32-bit RISC processor	32-bit RISC processor	32-bit RISC processor
RAM	128MB	128MB	128MB
Flash	128MB	128MB	128MB
Serial Communication	Number of ports	2*	2
	Com1	RS232	RS232 / RS485
	Com2	RS485	RS232 / RS485
USB Interfaces	USB Device	1x USB Device Type B micro	1x USB Device Type B micro
	USB Host	1x USB Host port	1x USB Host port
SD Card Slot	Type	1x microSD HC	1x microSD HC
	Capacity	High Capacity (4GB to 32GB)	High Capacity (4GB to 32GB)
	Speed Class	U1	U1
	UHS Speed Class	U1	U1
Ethernet Interface	1x 10/100 Mbps	1x 10/100 Mbps	1x 10/100 Mbps
RTC	Yes	Yes	Yes
Power Supply	24VDC (±15%)	24VDC (±15%)	24VDC (±15%)
Operating Temperature	0° to 60° C [#]	0° to 60° C [#]	0° to 60° C [#]
Storage Temperature	-20° to 85° C	-20° to 85° C	-20° to 85° C
Humidity	10 to 95% non condensing	10 to 95% non condensing	10 to 95% non condensing
Approvals	CE, UL Class I Div 2	CE, UL Class I Div 2	CE, UL Class I Div 2
Mounting	Front Panel Mounting, IP66 rated	Front Panel Mounting, IP66 rated	Front Panel Mounting, IP66 rated
Weight (Approximate)	200 gms.	400 gms.	900 gms.
Bezel Dimensions (mm)	120W x89H x 31.5D	186W x138H x 31D	268W x190H x 33D
Panel Cutout (mm)	111W x 80H	175W x 127H	256W x 178H

*PC3043 support one DB9 port that supports RS232 and RS485 levels on different pins. "Y" type cable can be used for separate RS232 and RS485 levels simultaneously.
[#]For UL, operating temperature range is 0° to 50°C

SOFTWARE FEATURES



Active Sync



.Net Compact Framework



Application Installer



Database (SQL CE 3.5)



Software Development Kit



Web Browser



Silverlight



PDF Viewer



Office Viewer



Word Pad



Media Player



Adobe Flash

ORDERING INFORMATION

PC3043TN	4.3" TFT, 24VDC, 2x Serial ports (1 RS232, 1 RS485), 1x USB device, 1x USB host, 1 Ethernet, 1x SD Card Slot
PC3070TN	7" TFT, 24VDC, 2x Serial ports (RS232/RS485), 1x USB device, 1x USB host, 1x Ethernet, 1x SD Card Slot
PC3102TN	10.2" TFT, 24VDC, 2x Serial ports (RS232/RS485), 1x USB device, 1x USB host, 1x Ethernet, 1x SD Card Slot
SKU	Windows CE 6.0 R3 Pro

DIMENSIONS

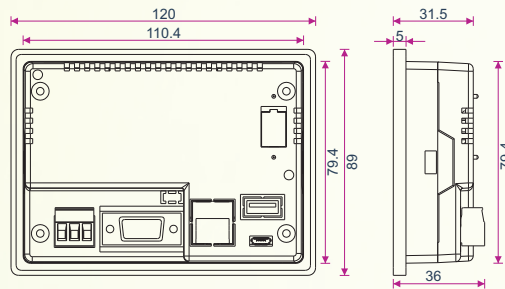

PC3043

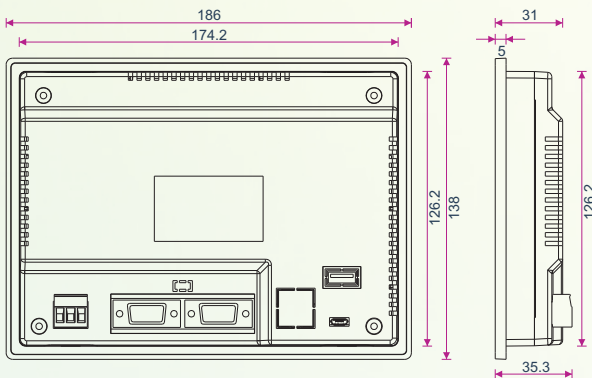

PC3070

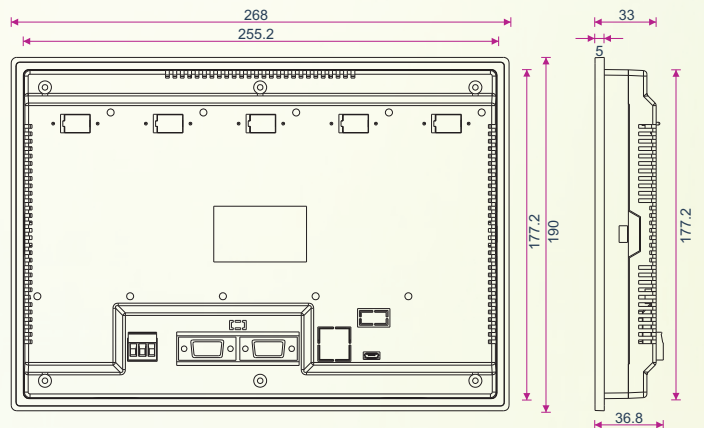

PC3102

Please contact factory for more information. We welcome an opportunity to develop new, custom drivers and customized units.

REGIONAL OFFICES

- Ahmedabad
- Bangalore
- Chennai
- Coimbatore
- Hyderabad
- Mumbai
- New Delhi

OVERSEAS DISTRIBUTORS

- USA
- Europe
- Asia Pacific