



GMW80 Series Carbon Dioxide, Humidity, and Temperature Transmitters for DCV



Features

- Superior stability with the advanced proprietary CARBOCAP® technology
- Improved accuracy due to low self-heating of microglow light source
- Modbus RTU support over RS-485 with model GMW87

Vaisala CARBOCAP® Carbon Dioxide, Humidity, and Temperature Transmitter Series GMW80 is based on Vaisala's patented latest-generation CARBOCAP technology with improved reliability and stability.

The GMW80 series transmitters are designed to fulfill the needs for CO₂ measurements in standard demand-controlled ventilation applications. Temperature measurement is included in most GMW80 series transmitters. Combined with humidity measurement, relay, and LED CO₂ level indication, GMW80 series provides you the flexibility needed for a variety of projects.

The CARBOCAP sensors measure CO₂ accurately immediately when powered on. As they have a built-in reference measurement they do not need a lengthy learning phase before the measured values are correct. Proper operation can be verified immediately after snapping on the device cover.

Easy installation

With modern buildings often having hundreds of sensors, installation time per unit can be a significant cost factor. Returning to the building site to check sensor operation adds further costs.

The GMW80 series transmitters include a number of subtle design features that have been introduced to make installation and commissioning quick and easy.

The pull-out tab makes opening the transmitter faster than before, while also doubling as a quality check slip and holder for the anti-tamper screw. The backplate can be twisted onto pre-mounted screws, and the wiring can be done easily on the clearly marked backplate. The electronics can be snapped on later when the building automation system is commissioned.

For measurements in more demanding conditions (for example, dusty or humid installation locations), the GMW87 and GMW88 models provide an IP64-rated enclosure with a cable gland.

Reliable operation

The GMW80 series transmitters are optimized for low maintenance. The unique, low-power CARBOCAP technology enables a longer lifetime and better stability than ever before. As the

power consumption is low, the heat generated by the electronics does not distort the temperature inside the sensor. The internal reference in the CO₂ sensor guarantees superior stability and flawless operation even in constantly occupied buildings, without the need for frequent readjustments.

The reliable operation and accurate measurement values of the GMW80 series transmitters contribute to the significant cost savings brought by demand-controlled ventilation.

Benefits

- Cost-efficient, affordable
- Reliable and maintenance-free operation for up to 15 years
- Easy to install, easy to use
- Versatile – works well in buildings occupied 24/7
- Ideal for demand-controlled ventilation

Technical data

Models

Model	Measurements	Output
GMW86P	CO ₂ +T	Current and voltage output, Pt1000
GMW83RP ¹⁾	CO ₂ +RH+T	Voltage outputs, Pt1000
GMW83DRP ¹⁾	CO ₂ +RH+T	Voltage outputs, Pt1000, Display
GMW83	CO ₂ +T	Voltage outputs
GMW83A	CO ₂ +T	Voltage outputs, CO ₂ indicator LEDs
GMW83D	CO ₂ +T	Voltage outputs, Display
GMW84	CO ₂ +T	Current output
GMW84S	CO ₂ +T	Current output, Relay
GMW87	CO ₂	RS-485 Modbus RTU output
GMW88	CO ₂	Current and voltage output

¹⁾ Models with calibration certificate available (GMW83RPC/GMW83DRPC)

Measurement performance

Carbon dioxide

Measurement range	0 ... 2000 ppm 0 ... 5000 ppm (GMW87)
-------------------	--

Accuracy across temperature range

+20 ... +30 °C (+68 ... +86 °F)	±(30 ppm +3 % of reading)
+10 ... +20 °C (+50 ... +68 °F), +30 ... +40 °C (+86 ... +104 °F)	±(35 ppm +3.7 % of reading)
+0 ... +10 °C (+32 ... +50 °F), +40 ... +50 °C (+104 ... +122 °F)	±(40 ppm +4.8 % of reading)

Stability in typical HVAC applications	±(15 ppm + 2 % of reading) over 5 years
--	---

Warm-up time	1 min 10 min for full specification
--------------	--

Response time (63 %)	60 s 7 min (GMW87 and GMW88)
----------------------	---------------------------------

Carbon dioxide sensor	Vaisala CARBOCAP® GM10
-----------------------	------------------------

Temperature

Measurement range	0 ... +50 °C (+32 ... +122 °F)
Temperature sensor	On P models: Pt1000 RTD Class F0.15 IEC 60751 For analog outputs: Digital temperature sensor

Accuracy (GMW83 and GMW84)

+10 ... +30 °C (+50 ... +86 °F)	±0.5 °C (0.9 °F)
+0 ... +10 °C (+32 ... +50 °F), +30 ... +50 °C (+86 ... +122 °F)	±1 °C (1.8 °F)

Humidity

Measurement range	0 ... 95 %RH
Accuracy for temperature range +10 ... +30 °C (+50 ... +86 °F)	±3 %RH
0 ... 80 %RH	±3 %RH
80 ... 95 %RH	±5 %RH
Accuracy for temperature ranges 0 ... +10 °C (+32 ... +50 °F), +30 ... +50 °C (+86 ... +122 °F)	±5 %RH
0 ... 95 %RH	±7 %RH
Stability in typical HVAC applications	±2 %RH over 2 years
Product lifetime	> 15 years

Operating environment

Operating temperature	0 ... +50 °C (+32 ... +122 °F)
Operating humidity	0 ... 95 %RH Dew point < 30 °C (+86 °F)
Storage temperature	Models without display: -40 ... +70 °C (-40 ... +158 °F) Models with display: -30 ... +70 °C (-22 ... +158 °F)
EMC compliance	EN 61326-1, Industrial environment

Inputs and outputs

Supply voltage	18 ... 35 VDC 24 VAC ±20 % 50/60 Hz
Max. current consumption at 18 VDC	45 mA 70 mA (GMW84 models)
Max. power consumption at 30 VAC	0.7 W (GMW83 models) 1 W (GMW86 models, GMW87, and GMW88) 1.2 W (GMW84 models)

Digital output (RS-485) (in GMW87 only)	Isolated, supports Modbus RTU protocol <ul style="list-style-type: none"> Modbus RTU address range: <ul style="list-style-type: none"> 1 ... 247 (up to 255 possible, non-standard) Bit rates: <ul style="list-style-type: none"> 4800, 9600, 19200, 38400, 57600, 76800, 115200 Parity: <ul style="list-style-type: none"> None or Even Supports automatically both 1 and 2 stop bits
---	--

Outputs	4 ... 20 mA and/or 0 ... 10 V ¹⁾
Current loop resistance (4 ... 20 mA)	0 ... 600 Ω
Voltage output load resistance	Min. 10 kΩ
CO ₂ output scale	0 ... 2000 ppm
Temperature output scale	0 ... +50 °C (+32 ... +122 °F)
Humidity output scale	0 ... 100 %RH
Passive temperature sensor (P models)	Pt1000 RTD
Temperature setpoint (T models)	10 kΩ potentiometer
Relay (S models)	1 pc, SPST-NO Max. 50 VDC / 50 VAC, 500 mA

CO ₂ indicator LED levels (A model)	Flashing red: > 2000 ppm Red: 1200 ... 2000 ppm Yellow: 800 ... 1200 ppm Green: < 800 ppm
--	--

¹⁾ Analog outputs are not available in model GMW87.

Mechanical specifications

IP rating	IP30 IP64 (GMW87 and GMW88)
Housing material	ABS/PC UL-V0 approved PC (GMW87 and GMW88)
Housing color	White (RAL9003)
Output connector	Screw terminal
Max. wire size	2 mm ² (AWG14)
Weight	Plain and LED version: 114 g (4.02 oz) Display version: 124 g (4.37 oz) GMW87 and GMW88: 160 g (5.64 oz)

Spare parts and accessories

CO ₂ module	GM10SP80
INTERCAP® sensor	15778HM

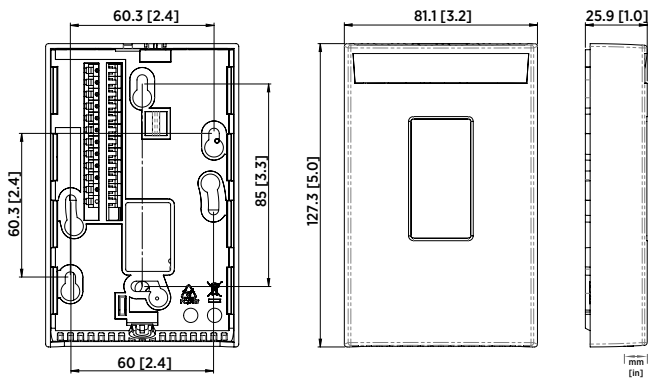

GMW83, GMW83A, GMW83RP, GMW84, GMW84S, GMW86P, GMW83D, and GMW83DRP dimensions (display in models with the letter D)

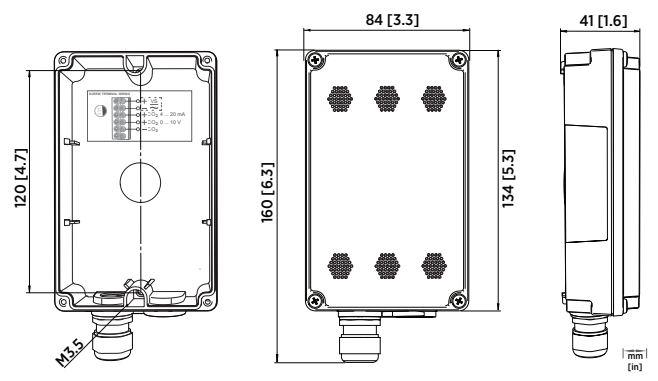

GMW87 and GMW88 dimensions



	www.esis.com.au
	Ph 02 9481 7420
	Fax 02 9481 7267
	esis.enq@esis.com.au

VAISALA

www.vaisala.com

Published by Vaisala | B211435EN-J © Vaisala 2020

All rights reserved. Any logos and/or product names are trademarks of Vaisala or its individual partners. Any reproduction, transfer, distribution or storage of information contained in this document is strictly prohibited. All specifications — technical included — are subject to change without notice.